

# PHYSICS

**For Rwanda Schools**

**Student's Book**

**Senior 3**

©2020 Rwanda Basic Education Board

This book is the property of Rwanda Education Board.

Credit should be given to REB when the source of this book is quoted.

# Contents

---

<b>1. Graph of linear motion .....</b>	<b>1</b>
Key unit competence .....	1
Unit Focus Activity .....	2
1.1 Uniform and non-uniform linear motion .....	3
1.2 Plotting graphs of linear motion .....	4
1.3 Analysing graphs of linear motion.....	14
Unit summary and new words.....	18
Unit Test 1 .....	19
<b>2. Friction Force and Newton’s Laws of Motion .....</b>	<b>24</b>
Key unit competence .....	24
Unit Focus Activity .....	25
2.1 Newton’s First law of motion .....	26
2.2 Linear momentum and impulse.....	28
2.3 Newton’s second law of motion .....	31
2.4 Newton’s third law of motion .....	36
2.5 Conservation of linear momentum .....	40
2.6 Coefficient of friction.....	47
Unit summary and new words .....	52
Unit Test 2 .....	53
<b>3. Applications of Atmospheric Pressure.....</b>	<b>57</b>
Key unit competence .....	57
Unit Focus Activity .....	58
3.1 Existence of atmospheric pressure .....	59
3.2 Factors influencing atmospheric pressure .....	62
3.3 Instruments for measuring atmospheric pressure .....	64
3.4 Applications of atmospheric pressure.....	67
Unit summary and new words .....	73
Unit Test 3 .....	74

<b>4. Renewable and non-renewable energy sources .....</b>	<b>76</b>
Key unit competence .....	76
Unit Focus Activity .....	77
4.1 Energy sources .....	78
4.2 Classification and characteristics of energy sources.....	78
4.3 Energy transformations.....	97
Unit summary and new words.....	103
Unit Test 4 .....	104
<b>5. Heat Transfer and Quantity of heat.....</b>	<b>107</b>
Key unit competence .....	107
Unit Focus Activity .....	108
5.1 Heat and temperature .....	109
5.2 Modes of heat transfer .....	110
5.3 Applications of heat transfer.....	118
5.4 Thermal expansion.....	122
5.6 Quantity of heat .....	138
Unit summary and new words .....	162
Unit Test 5 .....	163
<b>6. Laws of thermodynamics . .....</b>	<b>167</b>
Key unit competence .....	167
Unit focus Activity .....	168
6.1 Introduction to themodynamics .....	169
6.2 Internal energy of a system.....	170
6.3 First law of thermodynamics .....	171
6.4 Second law of thermodynamics .....	174
6.5 Heat exchange.....	177
6.6 Change of state and kinetic theory of matter .....	179
6.7 Applications of the principle of thermodynamics.....	183
6.8 Melting and solidification.....	185
Unit summary and new words .....	190
Unit Test 6 .....	191



<b>7. Introduction to Electromagnetic Induction .....</b>	<b>194</b>
Key unit competence .....	194
Unit focus activity .....	195
7.1 Demonstrations of electromagnetic induction .....	196
7.2 Factors affecting the magnitude of emf induced .....	201
7.3 Laws of electromagnetic induction .....	202
7.4 E.m.f induced in a straight conductor moving in a straight field .....	207
7.5 E.m.f induced in a coil rotating in a uniform magnetic field .....	210
7.6 Alternating current (a.c) generator .....	215
7.7 Root-mean square (r.m.s) value .....	217
7.8 Other applications of electromagnetic induction .....	220
Unit summary and new words .....	223
Unit test 7 .....	224
<b>8. Electrical Power Transmission .....</b>	<b>228</b>
Key unit competence .....	228
Unit focus Activity .....	229
8.1 Structure and working of a transformer .....	230
8.2. Types of transformers .....	233
8.3 Transformers equation .....	235
8.4 Power losses in transformers .....	240
8.5 Application of transformers .....	242
8.6 Electric power transmission .....	244
8.7 Environmental impact of power generation and transmission .....	248
Unit summary and new words .....	250
Unit test 8 .....	251
<b>9. Electric Field Intensity .....</b>	<b>253</b>
Key unit competence .....	253
Unit Focus Activity .....	254
9.1 Electrostatic Force and coulombs Law .....	255
9.2 Superposition of forces .....	258
9.3 Electric field .....	261
9.4 Electric Field Intensity .....	265

9.5	Electricfield patterns.....	270
	Unit summary and new words.....	274
	Unit test 9.....	274
<b>10.</b>	<b>House Electric Installation .....</b>	<b>277</b>
	Key unit competence .....	277
	Unit Focus Activity .....	278
10.1	Standard symbols for electrical installation .....	279
10.2	Electrical lamps and fuses .....	280
10.3	Types of electrical cables and their sizes.....	286
10.4	Household wirings.....	290
10.5	Dangers of electricity.....	294
10.6	Electrical safety .....	295
	Unit summary and new words.....	296
	Unit test 10.....	297
<b>11.</b>	<b>Basic alternating current circuits .....</b>	<b>299</b>
	Key unit competence .....	299
	Unit Focus Activity .....	300
11.1	Standard symbols used in electric circuit and function .....	301
11.2	Differences between alternating current (a.c) and direct current (d.c) ...	302
11.3	The circuit for analysing resistors, capacitors and inductors in a.c circuit	304
11.4	A single resistor connected in series to an a.c source.....	305
11.5	A single capacitor connected in series to an a.c source.....	310
11.6	A single inductor connected in series to an a.c source.....	315
11.7	Resistor, inductor and capacitor (RLC) in series with an a.c source .....	321
	Unit summary and new words.....	328
	Unit test 11 .....	328
<b>12</b>	<b>Refraction of light .....</b>	<b>331</b>
	Key unit competence .....	331
	Unit focus activity .....	332 ..
12.1	Phenomena of refraction of light.....	334
12.2	Refraction of light through a prism .....	355
12.3	Refraction of light through a thin lens .....	367

Unit summary and new words .....	397
Unit test 12 .....	399
<b>13. Telecommunication Channels .....</b>	<b>406</b>
Key unit competence .....	406
Unit Focus Activity .....	407
13.1 Definition of terms used in communication.....	407
13.2 Types of data Signals .....	409
13.3 Data transmission media .....	411
Unit summary and new words .....	428
Unit test 13 .....	429
<b>14. Properties of physical processes affecting plant growth.....</b>	<b>432</b>
Key unit competence .....	432
Unit Focus Activity .....	433
14.1 Environmental factors and their impact on plant growth .....	434
14.2 Biotic factors .....	452
Unit summary and new words .....	455
Unit test 14 .....	455
<b>15. Environmental phenomena and related physical concept .....</b>	<b>459</b>
Key unit competence .....	459
Unit Focus Activity .....	460
15.1 Environment and energy transfer .....	461
15.2 Application of laws of thermodynamics in energy transfer in the environment .....	461
15.3 Modes of heat transfer in the environment .....	462
15.4 Noise Pollution .....	466
15.5 Air pollution .....	468
15.6 Structure and composition of the atmosphere .....	472
15.7 Climate change science .....	474
15.8 The hydrosphere and hydrologic Cycle.....	482
15.9 Clouds.....	485
15.10 Cyclone and anticyclones .....	488
15.11 Global convectonal currents and wind patterns.....	490

15.12 Thermoregulation and the physics laws that govern it.....	492
Unit summary and new words.....	495
Unit test 15 .....	499
<b>Appendix AP1 .....</b>	<b>501</b>
<b>Appendix AP2 .....</b>	<b>502</b>
<b>Glossary.....</b>	<b>505</b>
<b>References .....</b>	<b>508</b>

**Key Unit Competence**

By the end of this unit, the learner should be able to plot and analyse the graphs of linear motion.

**Learning objectives****Knowledge and understanding**

- Describe graphs of uniform rectilinear motion.
- Plot distance - time graphs and velocity- time graphs.
- Identify uniform velocity and non-uniform velocity from displacement-time graphs.
- Identify uniform acceleration and non-uniform acceleration from velocity-time graphs.
- Identify uniform acceleration and Non-uniform acceleration from velocity-time graphs..
- Explain why the slope of a distance-time graph gives speed.

**Skills**

- Appreciate use of suitable scale in plotting graphs.
- Recognise that the area under velocity-time graph represents distance covered by the body.
- Determine the speed of a body from a distance time graph.
- Interpret velocity-time graphs.

**Attitude and value**

- Appreciate that the slope of distance -time graph gives velocity while the slope of velocity-time graph gives acceleration.
- Appreciate that linear motion can be represented using graphs.



## Introduction

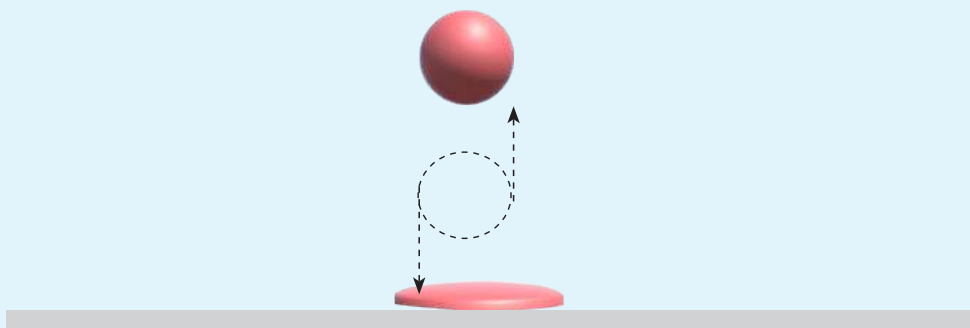
### Unit Focus Activity

#### Materials

- A small ball
- A dish

#### Steps

1. Place the dish on a level ground.
2. Place the ball directly above the dish at a reasonable height.
3. Allow the ball to fall freely onto the dish as shown in Fig. 1.1. Observe the ball as it hits the dish and make consecutive reboundies.



*Fig. 1.1: A bouncing ball*

4. Compare the consecutive reboundies. What do you notice? Account for the differences in rebound heights (if any).

5. Starting from the time the ball hits the dish, sketch for the first three bounces its:
- Displacement – time graph
  - Speed – time graph
  - Velocity – time graph

In our daily lives, we come across or interact with objects in motion. For example, people, animals and objects are from time to time involved in motion in various directions. The motion in a straight line is called **linear motion**, also referred to as **rectilinear motion**.

Graphs of linear motion help us to visualise and analyse various aspects of the motion including distance and displacement covered, speed and velocity, direction of motion and acceleration.

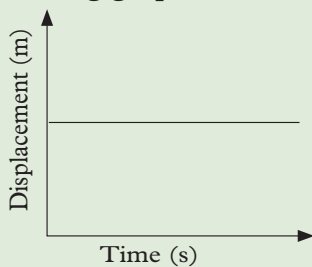
In this unit, we will draw motion graphs for objects moving in linear motion, analyse and interpret the motions as represented in the graphs.

## 1.1 Uniform and non-uniform linear motion

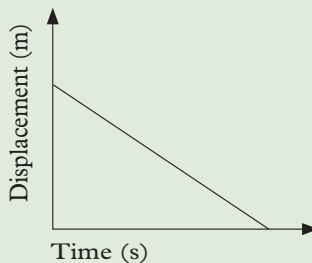
### Activity 1.1

To identify uniform and non-uniform linear motion

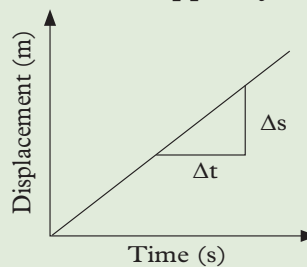
- Distinguish between uniform and non-uniform motion.
- Identify uniform linear motions and non-uniform linear motions from the following graphs. Give a reason in each case to support your decision.



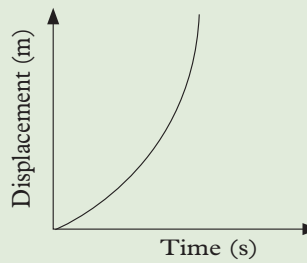
(a)



(c)



(b)



(d)

Fig. 1.2 (a) to (d): Graphs of uniform and non-uniform linear motion

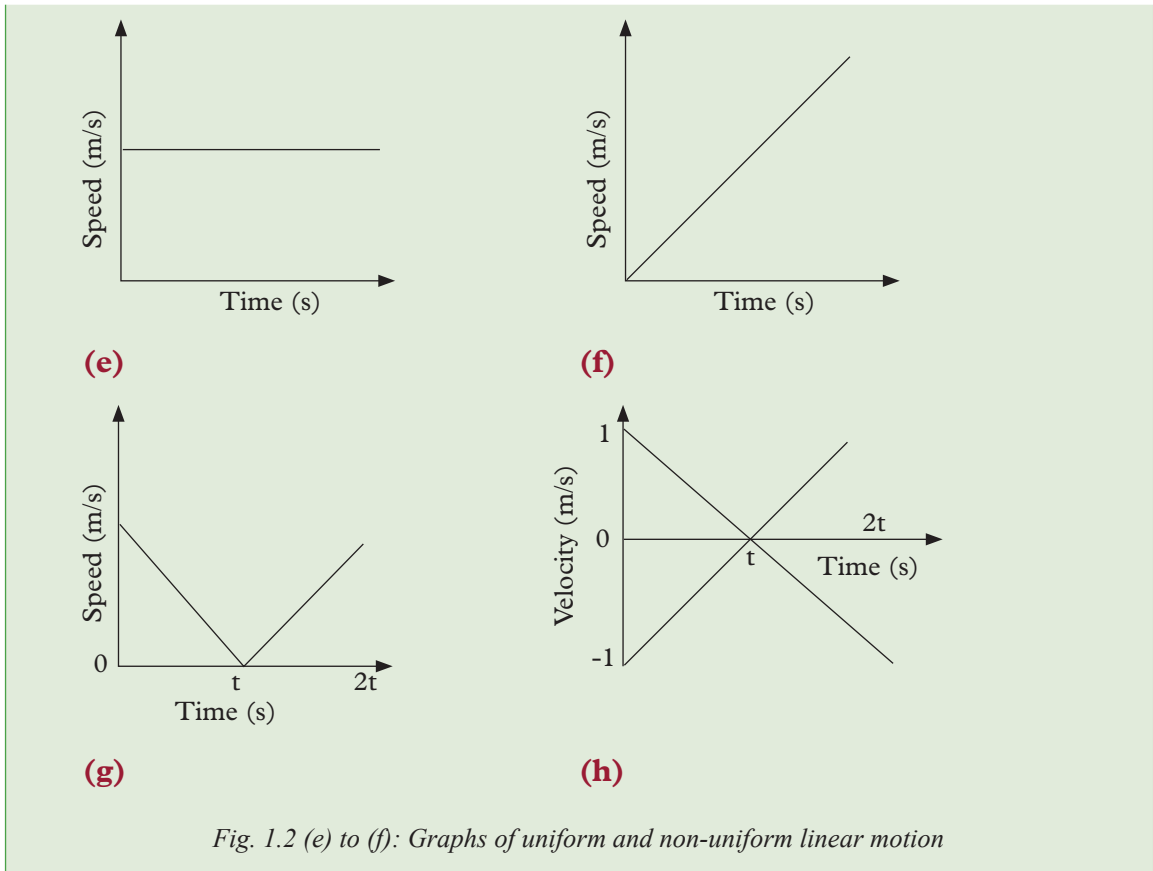


Fig. 1.2 (e) to (f): Graphs of uniform and non-uniform linear motion

**Uniform linear motion** is a type of motion in which the body moves with constant velocity. In other words, it moves with zero acceleration or along a straight path with constant speed. An example of this kind of motion is a car moving along a straight section of road at a constant speed. **Non uniform linear motion** is the kind of motion in which a body moves with a varying velocity. An example of a non-linear motion is a bouncing ball.

## 1.2 Plotting graphs of linear motion

### 1.2.1 Distance-time graphs

#### (a) Distance-time graph of an object moving with uniform speed

##### Activity 1.2

To plot a distance-time graph for an object moving with uniform speed

##### Materials

- Graph paper
- Geometrical set



## Steps

Table 1.1 shows the distance travelled with time by an object.

Table 1.1: Distance travelled with time by an object

Distance (m)	0	8	16	24	32	40
Time (s)	0	2	4	6	8	10

1. Plot a graph of distance against time from the data given in Table 1.1.
2. Describe the motion of the object based on the graph obtained.



**Note:** When drawing graphs determine a convenient scale that will give a graph that fits at least  $\frac{3}{4}$  of a normal graph paper.

The change in the position of an object with time can be represented on the distance-time graph. Such a graph helps us to visualise and analyse various aspects of the motion, e.g. the average speed or velocity of the body. Let us consider a moving body whose distance changes with time as shown in the table 1.2.

Table 1.2: Distance travelled with time by an object

Distance (km)	0	6	18	27	35	42	48
Time (s)	0	5	15	22.5	29	35	40

The distance-time graph of the body is as shown in Fig 1.3.

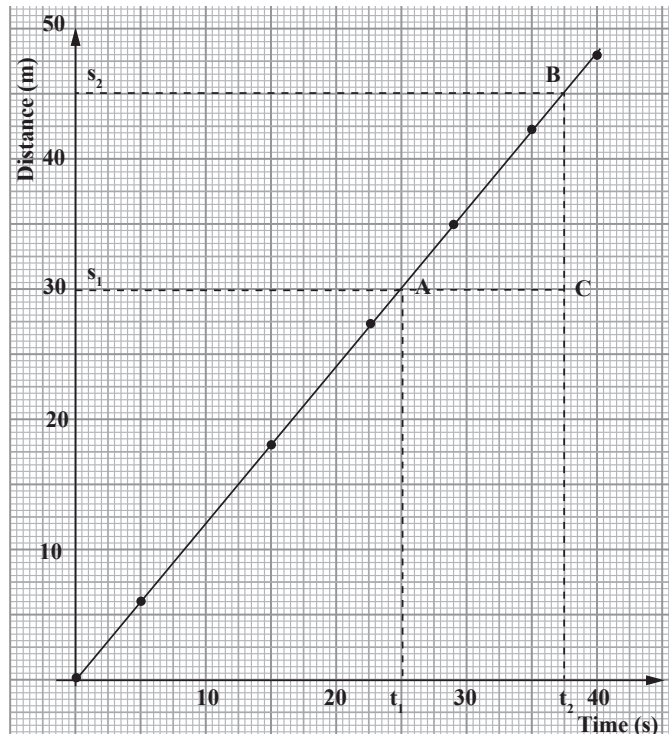


Fig. 1.3: Distance-time graph

From the graph in Fig. 1.3, the object travels equal distance in equal time intervals. It moves with uniform speed. Therefore, for a body moving with uniform speed, its distance-time graph is a straight line. In other words, the distance is increasing at a uniform rate. The term velocity is used instead of speed if the direction is specified.

### Determination of Speed/Velocity from distance-time graph

In the graph in Fig 1.3, the distance travelled from A to B is obtained as follows:

$$\text{Distance} = s_2 - s_1 = 45 \text{ m} - 30 \text{ m} = 15 \text{ m}$$

(where  $s_1$  is the initial distance and  $s_2$  is the final distance.)

$$\text{The time taken} = t_2 - t_1 = 37.5 \text{ s} - 25.0 \text{ s} = 12.5 \text{ s}$$

(where  $t_1$  is time at  $s_1$  and  $t_2$  is time at  $S_2$ .)

$$\begin{aligned} \text{Speed} &= \frac{\text{Distance travelled}}{\text{time taken}} = \frac{15 \text{ m}}{12.5 \text{ s}} \\ &= 1.2 \text{ m/s} \end{aligned}$$

∴ We see that,

speed = slope of the graph (see triangle of ABC in Fig. 1.3).

Since the speed is not changing, this is a case of **non-accelerating motion**.

### (b) Distance-time graph for an object moving with non-uniform speed

#### Activity 1.3

To plot a distance-time graph of an object with non-uniform speed

#### Material

- Graph paper
- Geometrical set

#### Steps

1. Consider a case of an object moving as shown in table 1.3

Table 1.3 Distance travelled with time by an object

Time (s)	0	2	4	6	8	10	12
Distance (m)	0	1	4	9	16	25	36

2. Plot a graph of distance against time from data given in Table 1.3.
3. Describe this type of motion based on your graph.
4. Find the gradient of the graph at point (6.2, 10). What does it represent?

The motion of a body moving with non-uniform speed can be presented on a graph. Such a graph helps us to identify time intervals when the body was either at rest, accelerating or moving at a constant speed. It also helps us to determine its velocity at any instance or average velocity in any given time interval.

Let us consider a case similar to the one in Activity 1.3. The distance covered with time by a body was recorded as shown in table 1.4.

Table 1.4: Distance travelled with time by an object

Distance (m)	0	5	12.5	25	45
Time (s)	0	2	4	6	8

The distance-time graph of the body is as shown in Fig. 1.4

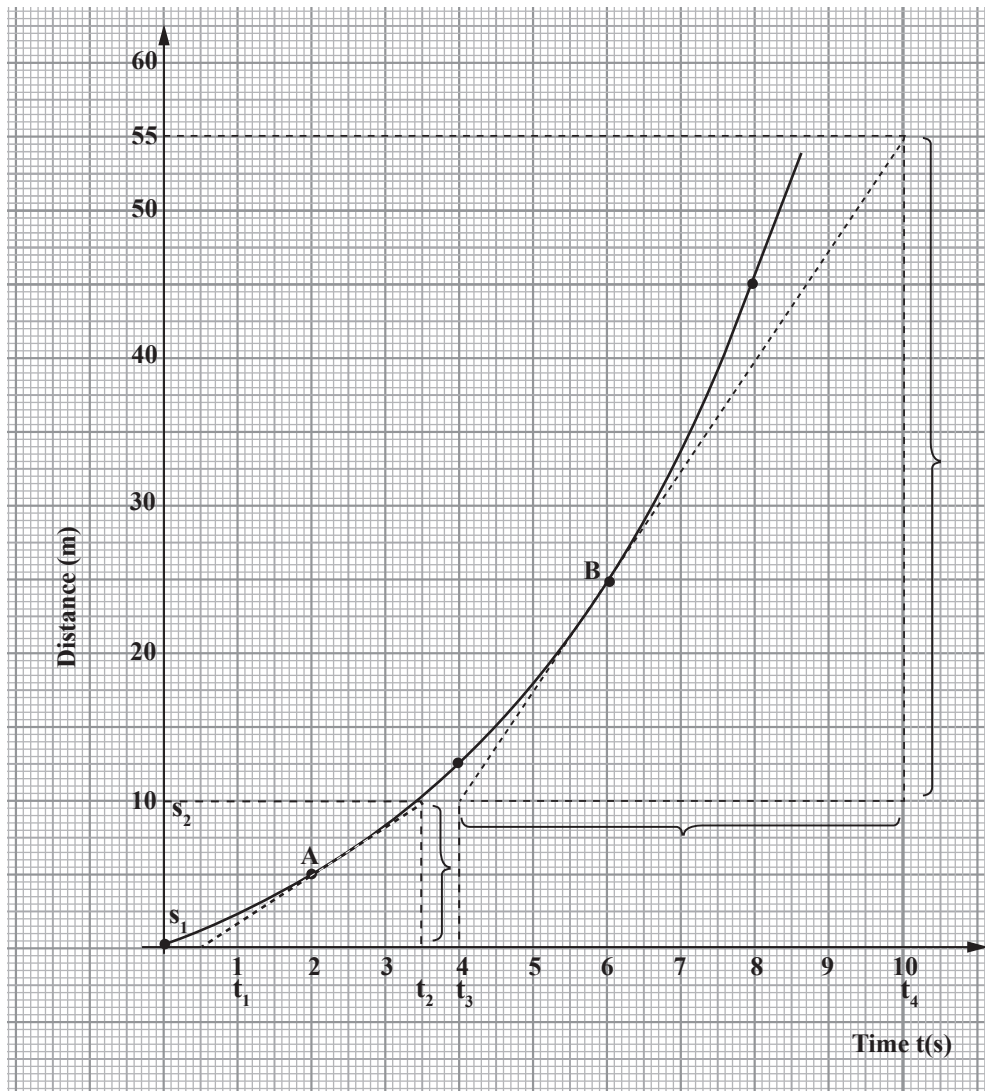


Fig. 1.4: Distance-time graph for non-uniform motion

The graph shows variation in the rate of distance covered in time. This represent motion with non-uniform speed.

### Determination of speed/velocity from the graph

The slope (gradient) of the graph i.e.  $\frac{\text{Change in distance}}{\text{Change in time}}$  or gradient =  $\frac{\Delta s}{\Delta t}$  where  $\Delta s$  is change in distance and  $\Delta t$  is change in time, represents speed/velocity of the object at any given point. Therefore, we can find the speed of the object at any instance by finding the slope of the graph at that point.

To do this, we draw a tangent to the curve at that point i.e. a line touching the graph at only that point, then find the gradient of that line.

At point A, instantaneous speed  $v_A = \frac{s_2 - s_1}{t_2 - t_1} = \frac{10 - 0}{3.5 - 0.5} = \frac{10}{3} = 3.3 \text{ m/s}$

At point B, instantaneous speed  $v_B = \frac{s_3 - s_2}{t_4 - t_3} = \frac{55 - 10}{10 - 4} = \frac{45}{6} = 7.5 \text{ m/s}$

We can see that the speed of the object is higher at point B than at point A hence the body is accelerating.

### Exercise 1.1

1. With the help of a sketch graph, explain how a body undergoes uniform linear motion.
2. What does the gradient from a distance-time graph represent? Explain.
3. Uwimana carried out an experiment with an object moving at different distances in different times and recorded the findings as shown on the table 1.5.

Table 1.5: Distance travelled with time by an object

Time(s)	20	30	40	50	60
Distance (m)	12	16	20	24	28

- (a) Plot a graph of distance (y-axis) against time.
  - (b) Find the slope of the graph.
  - (c) Describe the motion of the object.
  - (d) Give two reasons why drawing graphs of linear motion is important.
4. By giving an example, differentiate between uniform and non-uniform motion.

### 1.2.2 Velocity-time graphs

#### (a) Velocity-time graph for an object moving at a constant velocity

#### Activity 1.4

To show the variation of velocity with time using a ticker-timer

1. The table 1.6 shows velocity and time for a car moving in straight line.

Table 1.6: Velocities of a car at given times

Time (h)	0	15	25	30
velocity ( $\text{ms}^{-1}$ )	40	40	40	40

2. Plot a graph of velocity against time.
3. Describe the motion based on the graph obtained.

The velocity-time graph for a body moving at constant velocity is a straight line parallel to the x-axis. (Fig 1.5).

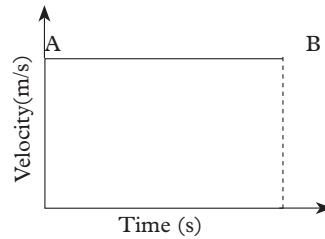


Fig 1.5: Velocity time graph

Since velocity is constant, then

$$\text{Velocity} = \frac{\text{displacement covered}}{\text{time}}$$

$$\therefore \text{Velocity} \times \text{Time} = \text{Displacement}$$

Looking at the graph in Fig. 1.5, we see that the distance covered from A to B is (given by velocity  $\times$  time covered) is equal to the area of the rectangle bounded by AB and the time axis. Therefore, distance covered by a body moving at constant velocity or speed from a velocity time graph is equal to the area under the graph in the section under consideration.

### Example 1.1

Fig. 1.6 shows the graph of velocity against time for body.

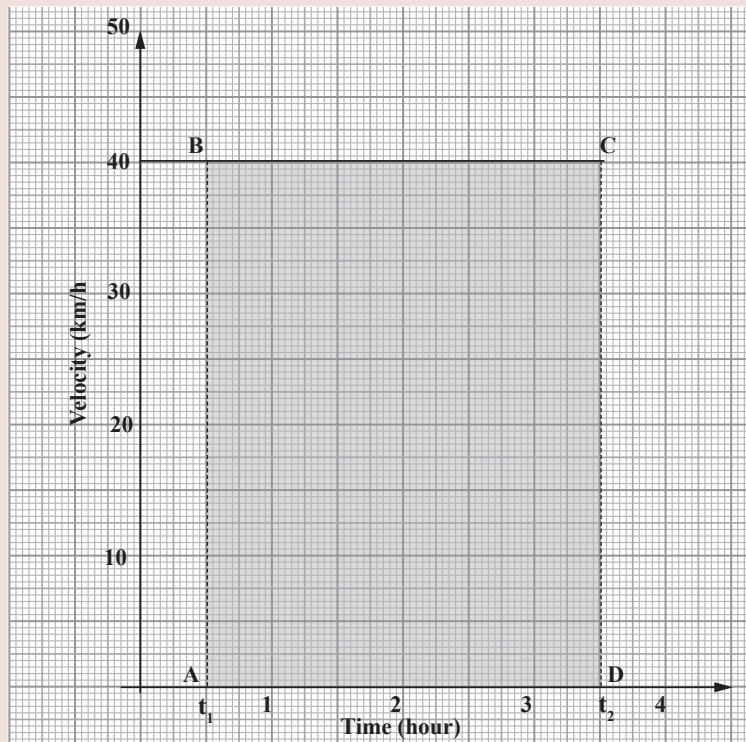


Fig. 1.6: Velocity-time graph for a body with constant velocity

Find the distance covered by the object between time  $t_1$  and  $t_2$ .

**Solution**

To determine the distance moved by the object between time  $t_1$  and  $t_2$  from the graph, we draw perpendicular lines  $t_1$  and  $t_2$  to the graph lines to get rectangle A B C D.

$$\begin{aligned} \text{The distance moved} &= \text{Velocity} \times \text{Time} \\ &= \text{Area of rectangle ABCD} \\ &= AB \times AD \\ &= 40 \text{ m s}^{-1} \times (3.5 - 0.5)\text{s} \\ &= (40 \times 3) \text{ m} \\ &= 120 \text{ m} \end{aligned}$$

The velocity does not change with time. This is a case of non-accelerated motion.



**Facts**

1. The area under velocity-time graph gives the distance covered by the body.
2. The gradient/slope of the velocity-time graph represents acceleration and in this case the slope is zero hence acceleration is zero.

**(b) Velocity – time graph for an accelerating/decelerating object.**

**Activity 1.5**

To determine the distance moved by an accelerating object from a velocity-time graph

**Materials**

- A long tape
- wooden block
- a runway
- ticker-timer
- trolley
- carbon disc
- cellotape

**Steps**

1. Pass the long tape under the carbon disc of the ticker-tape timer. Use cellotape to attach it to the trolley.
2. Now, increase the angle of inclination of the runway using the wooden block until the trolley is seen to be moving with increasing speed down the runway (See Fig 1.7).

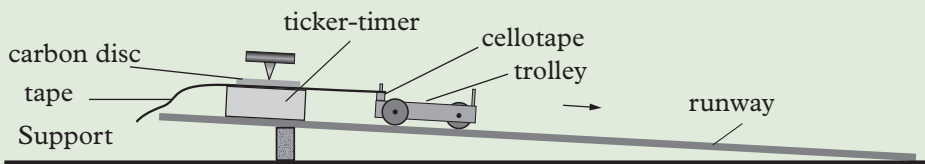


Fig. 1.7: To determine uniform velocity using a ticker-tape timer

3. Release the trolley and start the ticker-timer. What do you notice about the separation of adjacent dots on the tape? Explain.
4. Cut the tape through the dot produced just before the trolley was released.
5. Count five dot-to-dot spaces and cut the tape again. (If the dots are too close together to distinguish them, then you will have to estimate the ten spaces.)
6. Starting from your last cut, count ten more spaces, and cut again.
7. Repeat this, until you have a collection of consecutive tapes, each one longer than the one before it. Number your tapes, in the order 1 onwards.
8. Draw a horizontal line on a sheet of paper. Make a 'bar chart' by sticking the tapes in order vertically side by side, so that their bottoms just touch the horizontal line. The first and shortest tape should be at the left hand end of the line as shown in Fig.1.8.

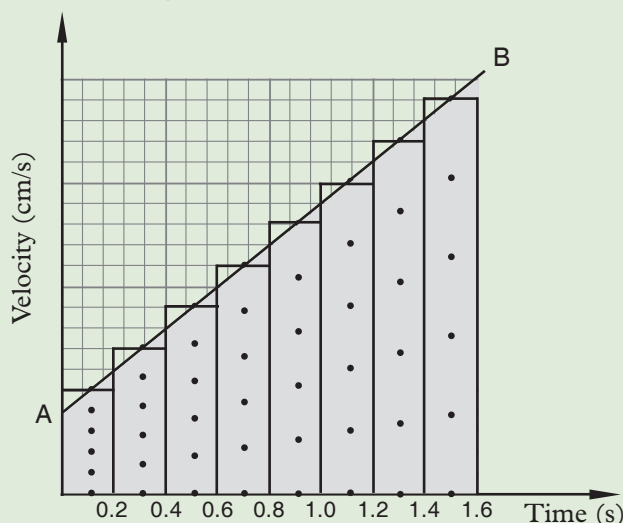


Fig. 1.8: Tape chart for constant acceleration

9. What does the horizontal axis represent in this case?. Mark your horizontal axis in intervals of 0.2s. What are the units for the horizontal axis?
10. Draw a vertical line through the zero of the time axis. This vertical line is the velocity axis. When time was zero for the trolley journey, velocity was zero. (The trolley started from standstill, or rest.)
11. Mark the scale on the vertical axis, in centimetres per second.
12. Draw a smooth line through the top-centre of each tape on your velocity-time graph. Describe in words what the graph says about the trolley motion.

When the velocity of a body is not constant, the body is either **accelerating** or **decelerating**. Consider an object whose motion is shown in the velocity-time graph in Fig 1.9.

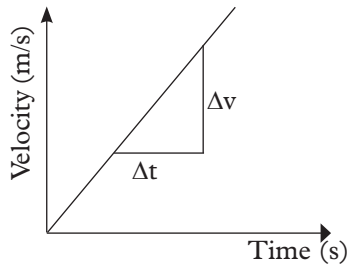


Fig. 1.9

The gradient =  $\frac{\text{Change in velocity}}{\text{Time taken}} = \frac{\Delta v}{\Delta t} = \text{acceleration}$

Thus, the gradient of a velocity-time graph gives the acceleration of the object. When the graph has a uniform slope (gradient), the body has uniform acceleration.

Consider a motion of a body whose velocity at regular time is as shown in table 1.7.

Table 1.7

<b>Time (s)</b>	0	5	10	15	20	25	30
<b>velocity (ms<sup>-1</sup>)</b>	0	9	18	27	36	45	54

The velocity-time graph of the body is as shown in Fig. 1.10.

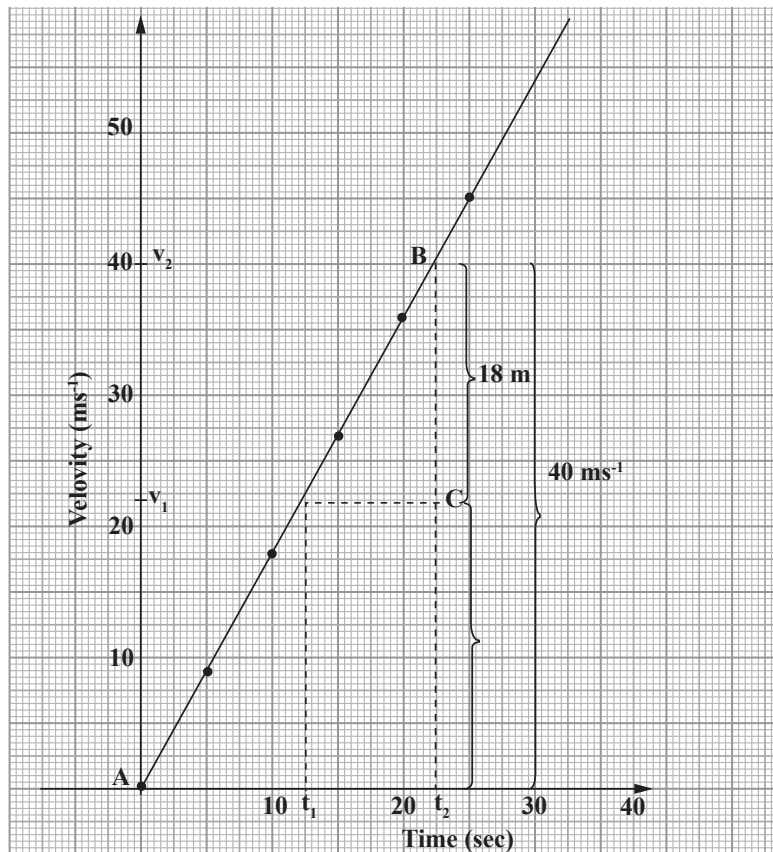


Fig. 1.10: Graph of velocity against time



$$\begin{aligned}
 \text{Change in velocity between } t_1 \text{ and } t_2 &= v_2 - v_1 \\
 &= 40 \text{ m/s} - 22 \text{ m/s} \\
 &= 18 \text{ m/s}
 \end{aligned}$$

$$\begin{aligned}
 \text{Change in time} &= t_2 - t_1 \\
 &= 22.5 \text{ s} - 12.5 \text{ s} \\
 &= 10 \text{ s}
 \end{aligned}$$

$$\text{Slope} = \frac{v_2 - v_1}{t_2 - t_1} = \frac{18 \text{ m/s}}{10 \text{ s}} = 1.8 \text{ m/s}^2$$

The velocity changes at the same rate in unit time. This is a case of uniformly accelerated motion.

When a velocity-time graph is a curve, then the body is moving with either increasing or decreasing acceleration as shown in the graphs in Fig. 1.11 and Fig. 1.12.

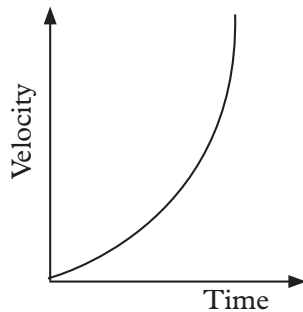


Fig. 1.11: Graph of body moving with increasing acceleration

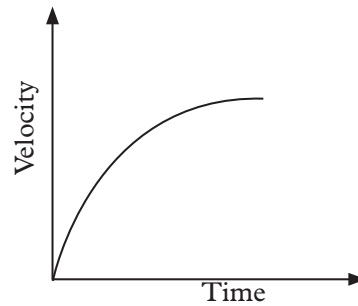


Fig. 1.12: Graph of body moving with decreasing acceleration

The instantaneous acceleration of the object at any instant of a body moving with non-uniform speed is given by the gradient of the graph at that point, in the same way we determined the instantaneous speed from the graph of a body moving with non-uniform speed earlier in this unit.



**Note:**

The slope/gradient of the velocity-time graph represents the acceleration of the body.

### Exercise 1.2

1. Differentiate between speed and velocity.
2. In a velocity-time graph, the slope obtained stand for?
3. The velocity of a body increases from 60 km/h to 90 km/h in 20 seconds. Calculate its acceleration.
4. An applied force changes the velocity of an object from 20 m/s to 36 m/s in 0.01 seconds. What is the acceleration produced?

### 1.3 Analysing graphs of linear motion

#### Example 1.2

Table 1.8 shows the data for the motion of a vehicle over a period of 7s.

Table 1.8: Displacement of a car with time

Time (s)	0	1	2	3	4	5	6	7
Displacement (m)	0	20	40	60	80	95	105	110

- (a) Plot a graph of displacement against time.
- (b) Describe the motion of the vehicle for the first 4 s.
- (c) (i) Determine the velocities at 5.0 s and 6.5 s. Hence or otherwise determine the average acceleration of the vehicle over this time interval.  
(ii) Comment on your answer.

#### Solution

(a) Fig. 1.13 shows the expected graph

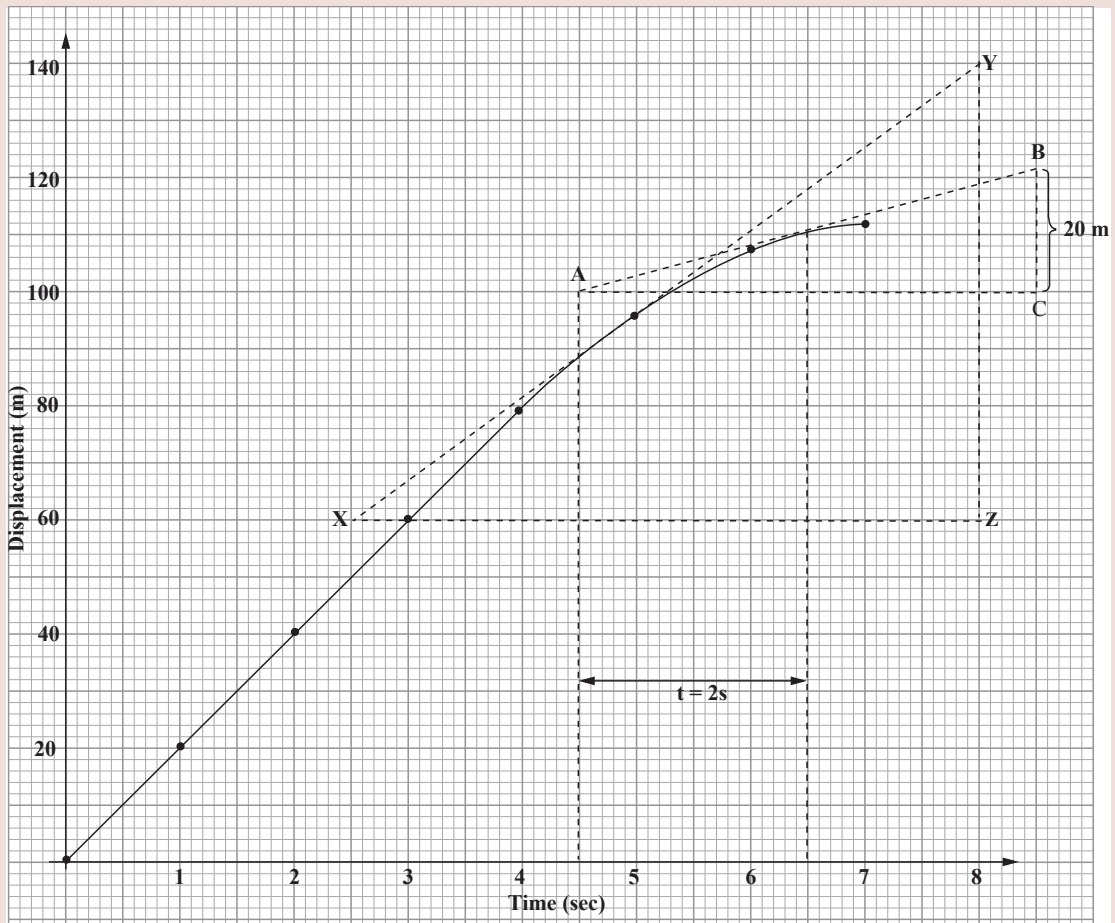


Fig. 1.13: Displacement-time graph

(b) The graph shows that vehicle moves with constant velocity (uniform velocity) in the first 4 s i.e. since the displacement is directly proportional to time i.e. linear relationship. The acceleration is zero.

(c) Instantaneous velocity  $t = 5.0$  s = slope at point  $t = 5.0$  s.

$$\begin{aligned} &= \frac{\Delta YZ}{\Delta XZ} = \frac{(140 - 60) \text{ m/s}}{(8 - 2.5) \text{ s}} \\ &= \frac{80 \text{ m/s}}{5.5 \text{ s}} \\ &= 14.5 \text{ m/s} \end{aligned}$$

Instantaneous velocity at  $t = 6.5$  s = slope at point  $t = 6.5$  s

$$\begin{aligned} &= \frac{\Delta ABC}{\Delta AC} = \frac{(121 - 100) \text{ m/s}}{(8.5 - 4.5) \text{ s}} \\ &= \frac{21 \text{ m/s}}{4.0 \text{ s}} \\ &= 5.25 \text{ m/s} \end{aligned}$$

$$\begin{aligned} \text{Average acceleration} &= \frac{\Delta v}{t} = \frac{v - u}{t} = \frac{(5.25 - 14.5) \text{ m/s}}{(5.5 - 4.0) \text{ s}} \\ &= \frac{-9.25 \text{ m/s}}{1.5 \text{ s}} \\ &\approx -6.17 \text{ m/s}^2 \end{aligned}$$

(ii) The negative sign means that the vehicle is decelerating.

### Example 1.3

Figure 1.14 shows a velocity-time graph of an object with uniform motion.

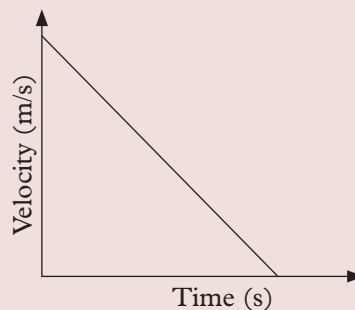


Fig 1.14: Velocity-time graph

- (a) Describe the motion of the object.  
 (b) Sketch the displacement-time graph of the motion (take motion upward as positive).

**Solution**

- (a) The object is decelerated uniformly and finally comes to rest.
- (b) Fig. 1.15 shows the displacement time graph for the motion.

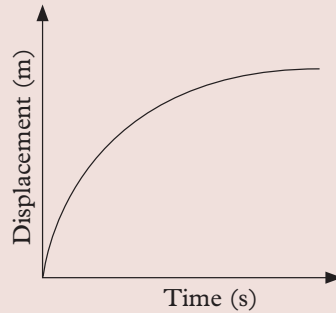


Fig. 1.15: Displacement-time graph

**Example 1.4**

Two cars X and Y are driven on the same 120 km trip. Car X travels at 80 km/h all the time. Car Y starts at the same time as, driving at 96 km/h, but the driver stops for fifteen minutes after he has travelled for half an hour then continues at the same speed.

- (a) Plot a graph of speed against time for two cars.
- (b) Which car is the first to arrive at the destination.

**Solution**

- (a) Fig 1.16 shows the motion and the expected graph of the two cars.

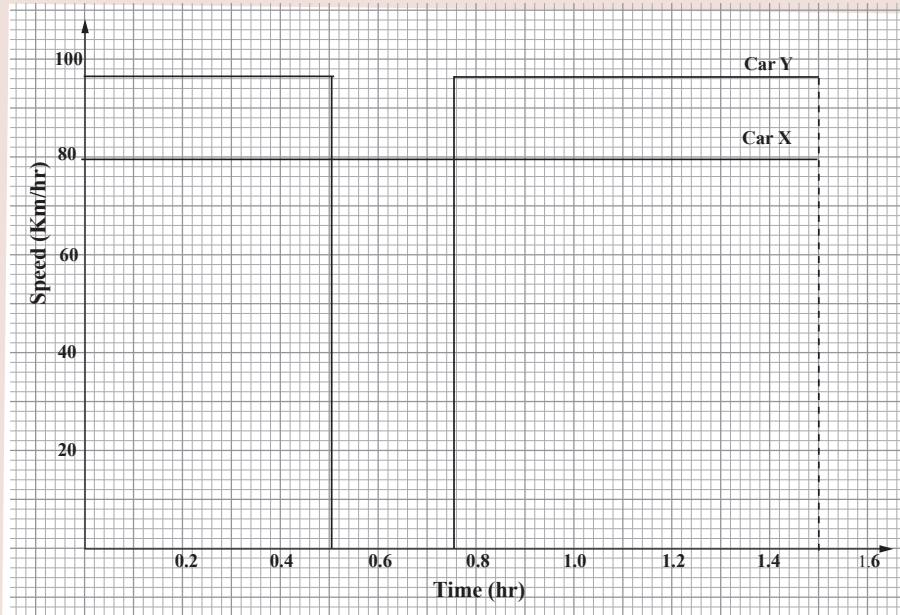


Fig. 1.16: Speed-time graph of two cars

**(b)** Car X travels 120 km at 80 km/h

$$\text{The time it takes} = \frac{\text{Distance covered}}{\text{Speed}} = \frac{120 \text{ km}}{80 \text{ km/h}} = 1.5 \text{ h}$$

Car Y travels the full distance of 120 km at 96 km/h

$$\text{Its total time in motion} = \frac{\text{Distance covered}}{\text{Speed}} = \frac{120 \text{ km}}{96 \text{ km/h}} = 1.25 \text{ h}$$

$$\text{Car Y rests for 15 minutes} = \frac{15}{60} \text{ h} = 0.25 \text{ h}$$

$$\begin{aligned} \therefore \text{total time by car Y} &= (1.25 + 0.25) \text{ h} \\ &= 1.5 \text{ h} \end{aligned}$$

$\therefore$  The two cars arrived at the same time.

### Exercise 1.3

- What do you understand by:
  - Accelerated motion.
  - Non-accelerated motion.
  - Give 2 examples for the motions in (a) and (b).
- Show that:
  - The slope of a displacement-time graph gives the velocity.
  - The slope of a velocity-time graph gives acceleration.
  - The area under the graph of velocity-time gives the displacement.
- The data for a journey made by a car is given in table 1.9

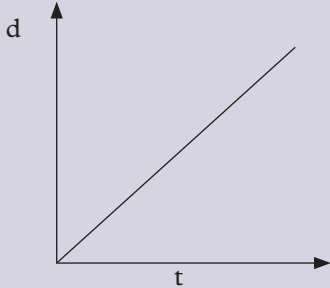
Table 1.9: Data for a car's journey

Time interval	Duration of interval (h)	Speed (km/h)
1	0.10	32
2	0.40	96
3	0.20	32

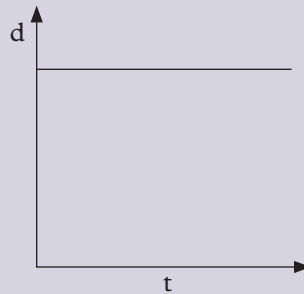
- How far does the car go in the first interval?
- Determine the total distance of the journey.
- Plot a graph of speed against time for this journey.
- Indicate the area on your graph which corresponds to the first 22.5 km/h of travel.

### Unit summary and new words

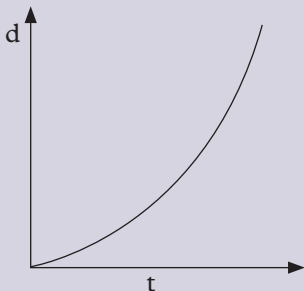
- Uniform linear motion is the motion of a body moving with constant velocity in a straight line.
- A displacement-time graph shows the variation of the displacement of an object with time. For example;



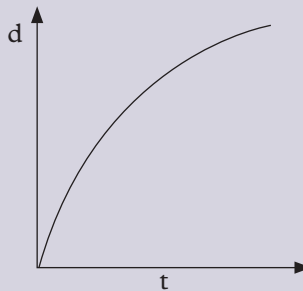
(a) Body moving with constant velocity away from origin



(b) Body at rest



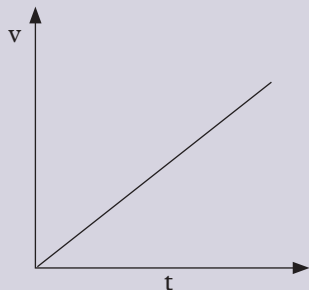
(c) Body moving with increasing acceleration



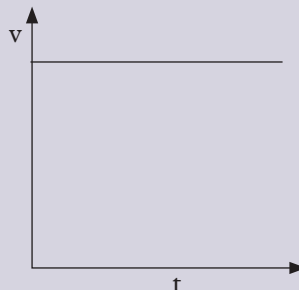
(d) Body moving with decreasing acceleration

Fig. 1.17: Displacement-time graph

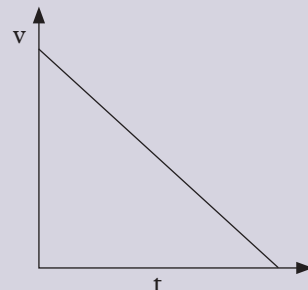
- The gradient (slope) of a displacement-time graph at any instance gives a velocity at that instance.
- A velocity-time graphs shows the variation of the velocity of a body with time. For example,



Body moving constant or uniform acceleration



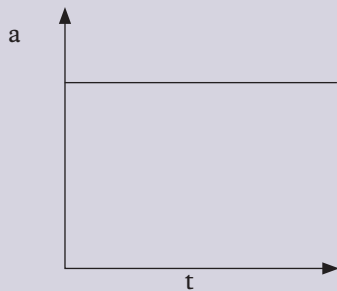
Body moving zero acceleration



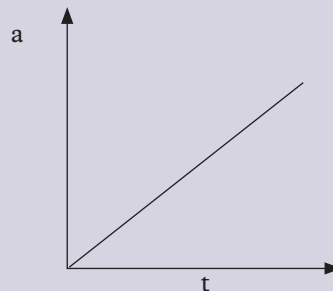
Body moving constant or uniform deceleration

Fig. 1.18: Velocity-time graph

- Instantaneous speed is the speed of a body at a specific moment in time.
- The gradient of a velocity-time graph at any instance gives the acceleration of the object at that point.
- The area under a velocity-time graph gives you the displacement of the object in the time interval under consideration.
- The following are acceleration – time graph for bodies moving with constant acceleration and uniformly increasing acceleration respectively.



(a) Body moving constant acceleration



(b) Body moving with uniformly increasing acceleration

Fig. 1.19: Acceleration-time graph

- When choosing the scale for plotting a graph, it must be simple and uniform.

## Unit Test 1

For questions 1 – 7, select the correct answer from the choices given.

- The slopes of a velocity-time graph is the
 

<b>A.</b> speed of body	<b>B.</b> velocity of body
<b>C.</b> acceleration of body	<b>D.</b> distance the body travelled
- A body has a constant velocity when
  - acceleration is increasing.
  - it is moving in a straight line.
  - the net force on the body is zero.

<b>A.</b> (iii) only	<b>B.</b> (i) and (ii) only
<b>C.</b> (i) & (iii) only	<b>D.</b> (ii) and (iii) only
- The velocity-time graph in Fig. 1.20 shows the motion of an object moving with
 

<b>A.</b> decreasing acceleration	<b>B.</b> constant acceleration
<b>C.</b> an increasing acceleration	<b>D.</b> constant velocity

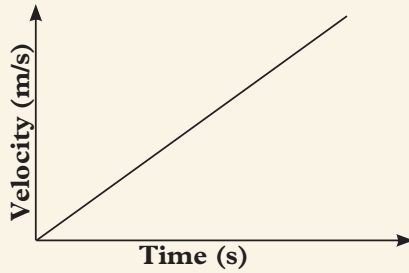


Fig. 1.20: Motion graph for an object

4. A body moves with uniform acceleration if
- A. Its momentum remains constant.
  - B. It covers equal distances in equal time.
  - C. The velocity change by equal amount in equal times.
  - D. The net force on the body is zero.
5. A cyclist travelling at a constant acceleration of  $2 \text{ m s}^{-2}$  passes through two points A and B in a straight line. If the speed of A is  $10 \text{ ms}^{-1}$  and the points are 75 m apart, find the speed at B.
- A.  $15.8 \text{ m s}^{-1}$
  - B.  $17.3 \text{ m s}^{-1}$
  - C.  $20.0 \text{ m s}^{-1}$
  - D.  $400.0 \text{ m s}^{-1}$
6. A lift accelerates from rest for 3 s. It then moves at uniform velocity for 15 s then decelerates uniformly for 2 s before coming to rest. Which of the following velocity - time graph in Fig. 1.21 represents the motion of the lift.

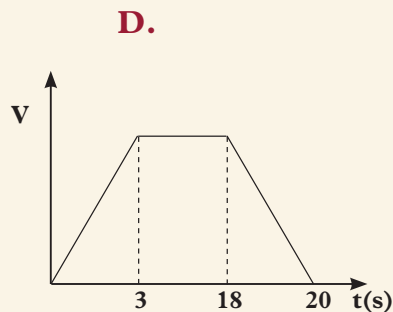
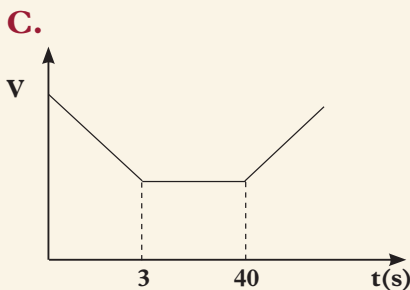
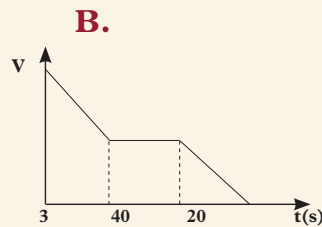
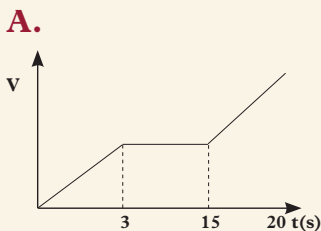


Fig. 1.21: velocity - time graph for a lift



7. Which of the following displacement time graph in Fig. 1.22 shows a car moving away from traffic lights at a steady speed towards the starting point?

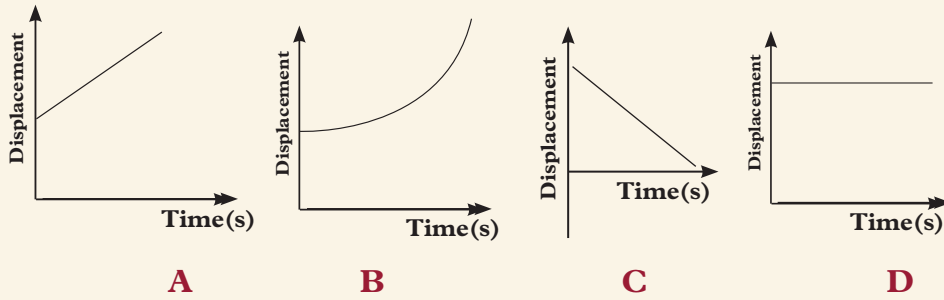


Fig. 1.22: Displacement time graphs

8. The graph in Fig. 1.23 represents variation of velocity with time of two athletes A & B.

- (a) Describe the motion of A and B  
 (b) What distance was covered by B in 50 s?

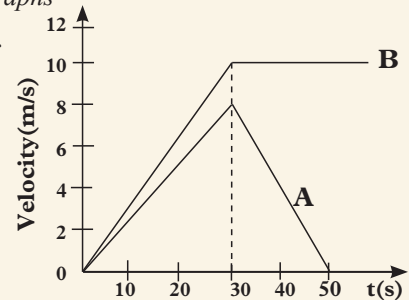


Fig. 1.23: Velocity-time graph

9. (a) What is meant by uniform velocity?  
 (b) A car travelling with a uniform velocity of  $25 \text{ ms}^{-1}$  for 5 s travels and then comes to rest under a uniform deceleration in 8 s.  
 (i) Sketch a velocity-time graph of the motion.  
 (ii) Find the total distance travelled.
10. Define the following:  
 (a) Instantaneous velocity                      (b) Average velocity
11. Explain how you can determine:  
 (a) Velocity from a displacement-time graph.  
 (b) Displacement from a velocity-time graph.  
 (c) Acceleration from velocity-time graph.
12. Sketch a velocity-time graph to show the motion of a body moving with:  
 (a) uniform acceleration.                      (b) zero acceleration.
13. Table 1.10 shows the instantaneous speed of a vehicle at intervals of 1 second.

Table 1.10: Instantaneous speeds of a car with time

Time (s)	0.0	1.0	2.0	3.0	4.0	5.0	6.0
Speed (m/s)	10.0	12.4	14.8	17.2	19.6	22.0	24.4

- (a) Plot a graph of speed against time .
- (b) Use your graph to determine:
  - (i) How fast the vehicle is travelling at 2.6 s and 4.8 s.
  - (ii) How far the vehicle travelled between the two instants in part (i)
  - (iii) Slope of the graph.

14. The distance-time graph of a motorbike travelling along a road is as shown in Fig. 1.24. Plot a graph of its speed against time.

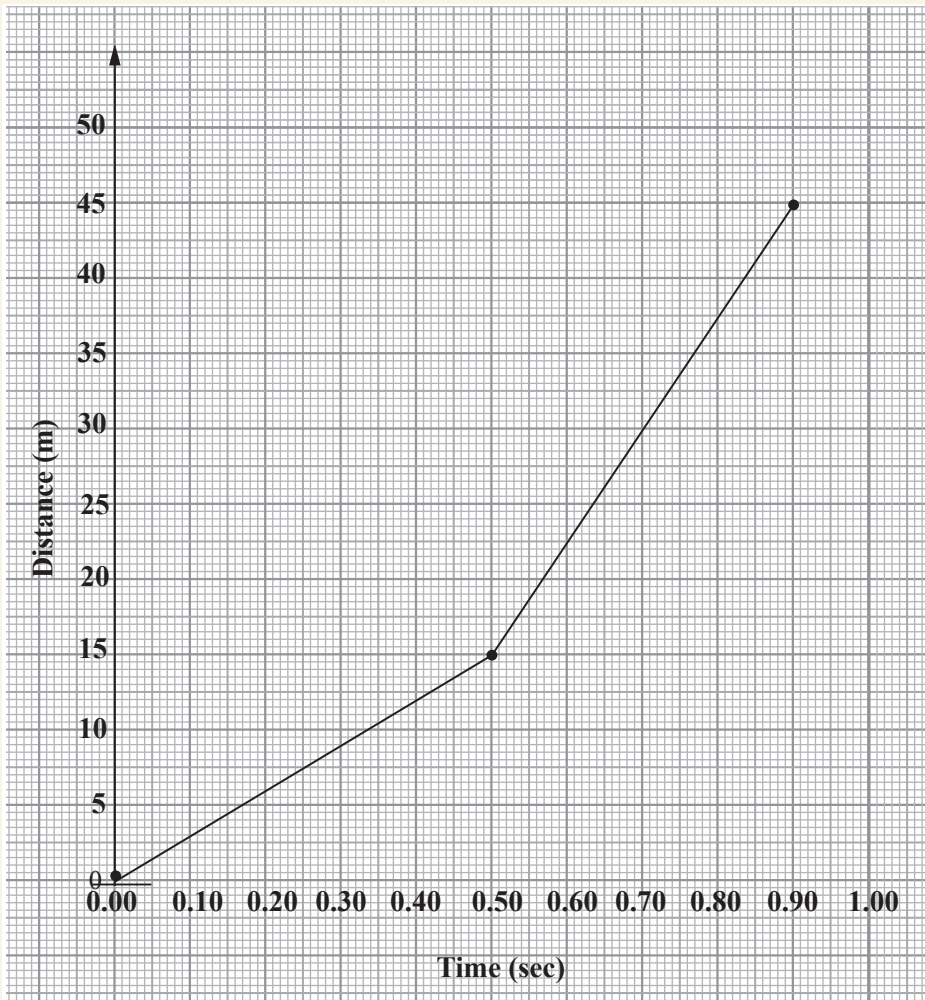


Fig. 1.24: Distance-time graph of a motorbike

**Be Safe!!**

Do you know that motorcycles contribute most of the deaths caused by road accidents in Rwanda? Always follow traffic rules. Wear helmets whenever you are on a motorbike, and never be more than two people on a motorbike.

15. A train moves according to the speed-time graph shown in Fig. 1.25.

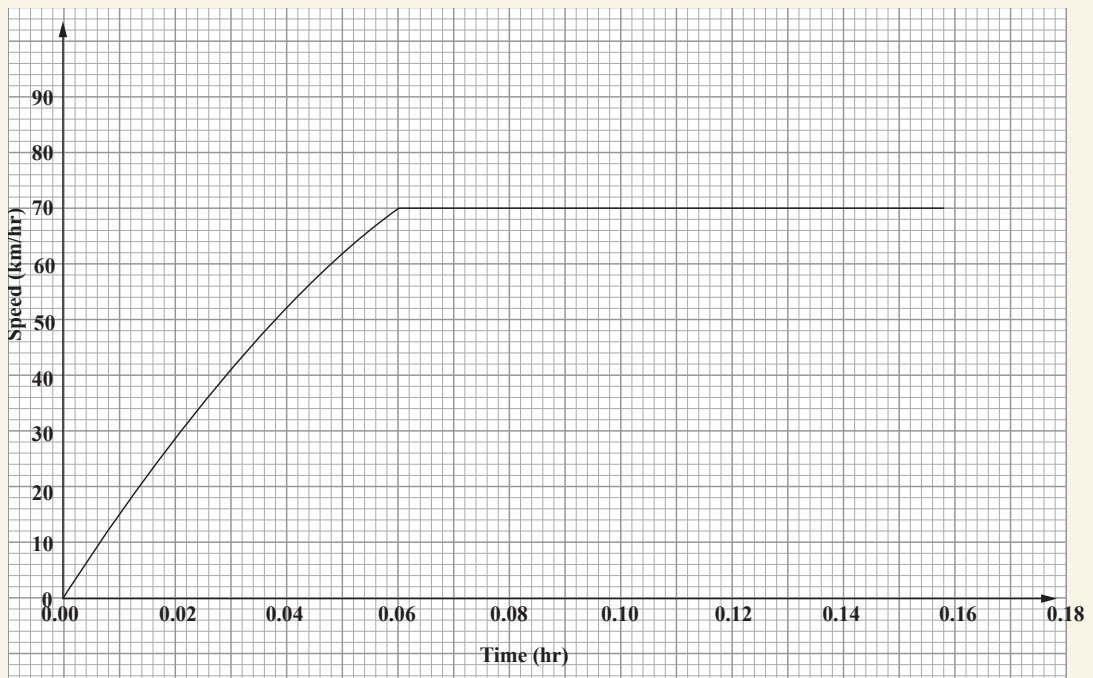


Fig. 1.25: Speed-time graph of a train

How far does it travel in the first six minutes?

## UNIT

## 2

# Friction Force and Newton's Laws of Motion

### Key Unit Competence

By the end of this unit, the learner should be able to perform experiments involving Newton's laws of motion and friction force.

### Learning objectives

#### Knowledge and understanding

- Explain inertia.
- Outline and explain factors affecting inertia.
- State and explain Newton's laws of motion.
- Describe why objects resist changes.
- Describe linear momentum and its conservation.
- Describe motion of objects on a horizontal plane with or without friction.
- Determine coefficient of friction.

#### Skills

- Design experiments to illustrate Newton's laws of motion.
- Investigate effects of friction force on motion.
- Apply Newton's laws principles in solving motion problems.

#### Attitude and value

- Appreciate the effect of friction force on moving body.
- Realise the effect of air resistance on the speed of moving objects.
- Appreciate the importance of Newton's laws of motion in life.
- Protection of persons by safety belts in a moving car.



## Introduction

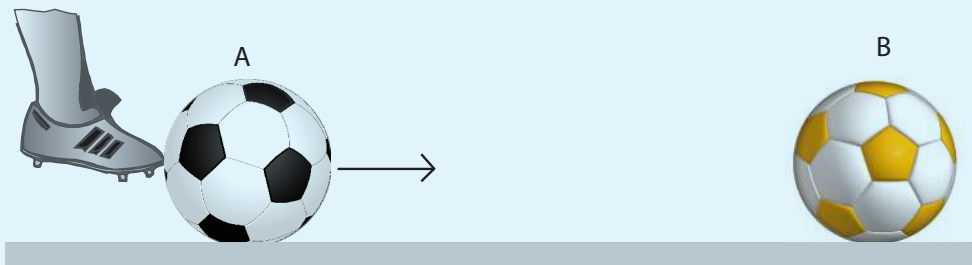
### Unit Focus Activity

#### Materials:

- Two balls
- Clear flat ground

#### Steps

1. Place one ball A, at a point on the flat ground.
2. Place the second ball B, on the ground at small distance from the first ball. Kick ball A carefully so that it moves to strike ball B (Fig. 2.1).



*Fig. 2.1: One ball moving to hit a stationary one*

3. Describe and explain what happens to the velocity of each ball after collision.
4. If instead a smaller ball C was used in place of ball A but kicked with the same force, compare the velocities of ball B in both cases. Explain the difference if any.

5. What quantity possessed by balls A and C is passed on to ball B? What two factors determine the magnitude of this quantity?
6. State Newton's second law of motion and explain how it governs the events during and after the collisions of the balls.
7. Why does ball B start slowing down and eventually stop after some time and distance on the ground?
8. Share your observations and facts to the rest of the class in a class discussion.

Everyday, we interact with forces. The forces can cause different effects such as change in motion, pressure as well as turning moments on an object. The effects of force on motion of a body are summarised by Newton's three laws of motion. In this unit, we will investigate each of these laws in details.

## 2.1 Newton's First law of motion

### Activity 2.1

#### To demonstrate inertia using a coin and cardboard

#### Materials

- Table or bench
- a smooth cardboard
- coin

#### Steps

1. Place the cardboard on the table with a small section of it extending beyond the edge of the table. Place the coin on the cardboard (Fig. 2.2).

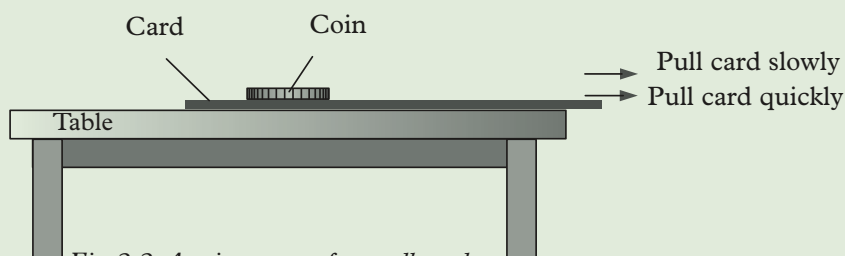


Fig. 2.2: A coin on top of a cardboard

2. Pull the cardboard gradually and observe what happens to the cardboard and the coin.
3. Return the cardboard and the coin to their initial position. Now pull the cardboard abruptly and observe what happens to the cardboard and the coin.
4. Explain your observations in steps 2 and 3.
5. Discuss in your groups and make a presentation on the role of safety belts in a car.

The effects of a force on a body either at rest or in uniform motion summed up under Newton's first law of motion which states that **a body remains in its state of rest or uniform motion in a straight line unless acted upon by an external force.**

Newton's first law of motion suggest that matter has an in-built reluctance to change its state of motion or rest. For instance, when a moving bus comes to an abrupt stop, the passenger lurch forward, i.e. tend to keep on moving. Likewise, when a bus surge forward, the passengers are jerked backwards, i.e. tend to resist motion.

The property of matter to resist change to its state of motion i.e. either to remain at rest or to continue moving in straight line is known as **inertia** (latin word meaning laziness). This explains why cars have seat belts. The seat belts (see Fig. 2.3), hold passengers onto the seat incase the vehicle comes to a stop or decelerates suddenly, preventing them from lurching forward. This reduces any chances of serious injury incase of an accident.



Fig. 2.3: A person wearing safety belt



**Note:** Newton's first law of motion is also known as the law of inertia

## Factors affecting inertia of a body

### (a) Mass of a body

The mass of a body is a measure of its inertia. A large mass require a large force to produce a given acceleration or deceleration than a smaller mass. A larger mass therefore has a greater inertia.

### (b) Acceleration of a body

As the acceleration of a body increases so does its tendency to continue at a constant velocity.

### (c) Force applied on a body

When the force applied on a body is increased, its tendency to remain at rest is reduced. This would result to movement of the body from its resting state.

### (d) Friction acting on a body

The law of inertia states that an object / body will keep moving at a constant velocity unless a force is applied in it. An example of such a force is friction. It is a force that makes a body to slow down. Without it, the body would continue moving at the same velocity without slowing down.

#### Exercise 2.1

1. Define the term 'inertia.'
2. State the law of inertia.
3. Briefly explain why wearing safety belts in moving vehicles is very important.

## 2.2 Linear momentum and impulse

### 2.2.1 Linear momentum

#### Activity 2.2

To illustrate linear momentum

#### Materials

- Two hammers (light and heavy)
- Four identical nails
- Wooden block

#### Steps

1. Take two nails and drive them into two pieces of wood using a light hammer.
2. Hit the first one gently and the second nail very hard. What happens in each case?
3. Repeat the activity using a heavy hammer (Fig. 2.4). What do you notice?.

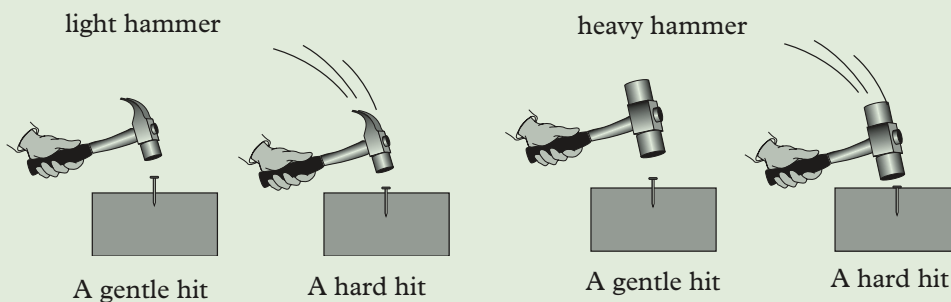


Fig. 2.4: Driving a nail into wood.

4. Highlight two factors on which the penetration distance of the nail depends.
5. Discuss with your classmate what the term 'linear momentum' means.



To drive a nail into wood, a certain rate of motion (velocity) and mass of the hammer is required. The quantity involving both motion and mass of a body is called *linear momentum*. It is denoted by the letter **p** and is called *momentum* in short.

*Linear momentum of an object is defined as the product of the mass and the velocity of the object. i.e.*

$$\begin{aligned} \text{momentum, } p &= \text{mass} \times \text{velocity} \\ \text{In symbols } p &= m \times v \end{aligned}$$

The *SI unit of momentum* is *kg m/s*. Momentum is a *vector quantity*. The direction of momentum is the same as that of the velocity.

### Example 2.1

A car of mass 600 kg moves with a velocity of 40 m/s. Calculate the momentum of the car.

#### Solution

$$\begin{aligned} \text{Momentum} &= \text{mass} \times \text{velocity} \\ &= 600 \text{ kg} \times 40 \text{ m/s} \\ &= 24\,000 \text{ kg m/s} \end{aligned}$$

### Example 2.2

A body A of a mass 4 kg moves to the left with a velocity of 7 m/s. Another body B of mass 7 kg moves to the right with a velocity of 6 m/s. (Fig. 2.5).

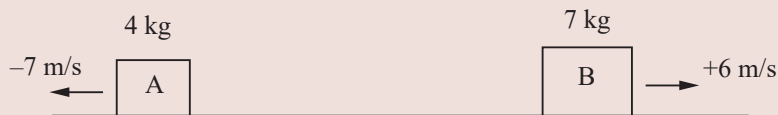


Fig. 2.5

Calculate (a) the momentum of A, (b) the momentum of B, (c) the total momentum of A and B.

#### Solution

Let us assign positive sign to indicate movement to the right and a negative sign to indicate movement to the left.

- (a) Momentum of A =  $4 \text{ kg} \times (-7) \text{ m/s} = -28 \text{ kg m/s}$
- (b) Momentum of B =  $7 \text{ kg} \times (+6) \text{ m/s} = +42 \text{ kg m/s}$

$$\begin{aligned}
 \text{(c) Total momentum} &= (\text{momentum of A}) + (\text{momentum of B}) \\
 &= -28 \text{ kg m/s} + 42 \text{ kg m/s} \\
 &= +14 \text{ kg m/s} \\
 &= 14 \text{ kg m/s to the right}
 \end{aligned}$$

### 2.2.2 Impulse

#### Activity 2.3

To demonstrate impulse using a ball.

#### Material

- ball
- pin
- wall

#### Steps

1. Take an inflated ball provided to you and remove some air from it using the pin. (Be careful not to destroy the inner tube).
2. Press the ball using your finger. What do you observe? Withdraw the finger. What do you observe? Explain.
3. Give the ball a strong kick towards a wall and observe the point of contact between your foot and the ball during the time of contact and between the wall and the ball respectively. What do you observe? What happens to the point of contact on the ball after bouncing back? Explain.
4. Discuss with your classmates what impulse is.
5. Suggest examples in daily lives that demonstrate impulse.
6. Discuss the difference between impulse and linear momentum.
7. Make short notes on your findings and report to the whole class.

When a force  $F$  acts on an object for a very short time  $t$ , it produces an impact, usually referred to as *impulse* on the object.

*Impulse is defined as the product of force and time i.e.*

*Hence Impulse = Force  $\times$  time*

*In symbols:  $I = Ft$*

*The SI unit of impulse is newton - second (N s).*

When an impulsive force acts on an object, it produces a change in the momentum of that object. The velocity of that object changes from an initial value  $u$  to a final value  $v$ . Its mass  $m$  remains constant.

Experiments have shown that the impulse acting on the object is equal to the change in momentum it produces on the object.

$$\text{Impulse} = \text{Change in momentum}$$

$$Ft = mv - mu$$

### Example 2.3

A hammer strikes a metal rod with a force of 20 N. If the impact lasts 0.4 s, calculate the impulse due to this force.

#### Solution

$$\begin{aligned} \text{Impulse} &= \text{Force} \times \text{time} \\ &= 20 \text{ N} \times 0.4 \text{ s} \\ &= 8 \text{ Ns} \end{aligned}$$

### 2.2.3 Distinction between impulse and linear momentum

Impulse and linear momentum are two quantities that confuses many. Table 2.1 will help us to differentiate the two.

Table 2.1: Differences between impulse and momentum

Impulse	Linear momentum
1. Impulse is product of the force and the time the force acts on an object Impulse = force (F) $\times$ time (t)	1. It is the product of velocity and the mass of an object Momentum = Mass $\times$ Velocity
2. Its SI units is Newton-second (N s)	2. Its SI unit is kilogram-metre per second (kg m/s)

The knowledge of impulse will help us to understand the law of conservation of momentum which we shall discuss later in this unit.

## 2.3 Newton's second law of motion

### Activity 2.4

To demonstrate and define Newton's second law of motion

#### Materials

- Two trolleys (heavier and light one)
- Spiral spring or rubber bands

**Steps**

1. Place the two trolleys on a smooth flat surface (floor or a table surface).
2. Connect the heavier trolley to the lighter one using a spiral spring or rubber bands provided.
3. Move the trolleys away from each other till they are about 1m apart.
4. Release them at the same time. Observe the difference in their velocities and acceleration. Which trolley accelerates faster?
5. Based on your observations in this activity, suggest relationship between the applied force, mass of an object and the acceleration produced by the force on the body.
6. Explain your observation using Newton's Second law of motion in term of momentum?
7. Compare your finding with those of other classmates.

**Note:**

It is a good idea to visit youtube on their website link: <https://www.youtube.com/watch?v=AFwbcWIUwLQ> for more demonstration on the Newton's laws of motion.

As we have already learnt, one of the effects of a force is that it changes the state of motion of an object. i.e. it causes a body at rest to move and a moving body to accelerate or come to rest. Any change in the velocity of a body causes a change in its momentum.

Newton summarised this effect on a body in his **second law of motion** which states that *the rate of change of momentum is directly proportional to the resultant force in a body and it takes place in the direction in which the force acts.*

Mathematically, the law is represented as follows:

$$\text{Force (F)} = \frac{\text{change in momentum}}{\text{time taken}}$$

$$\text{Force(F)} = \frac{\text{final momentum} - \text{initial momentum}}{\text{time taken}}$$

If  $m$  is the mass of the body and taking  $u$  and  $v$  to represent initial and final velocities respectively, while  $t$  representing time,

*Initial momentum = mass × initial velocity (mu)*

*Final momentum = mass × final velocity (mv)*

*Change in momentum = final momentum – initial momentum*

$$= mv - mu$$

*Rate of change of momentum =  $\frac{mv - mu}{t}$*

$$= m \left( \frac{v - u}{t} \right)$$

$$\text{but } \frac{v - u}{t} = a$$

Therefore rate of change of momentum = ma

But  $F \propto ma$

Thus,  $F = kma$  where  $k$  is a constant of proportionality.

Experiments show that  $k = 1$ , Therefore,

$$F = ma.$$

This is the mathematical representation of Newton's second law. The relationship  $F = ma$  shows that the greater the force applied on an object the more acceleration it causes on the object.

If mass is 1 kg and acceleration is 1 m/s<sup>2</sup>, then the force is 1 N. This is the definition of 1 newton i.e. *1 newton is the force which when it acts on a mass of 1 kg, it gives an acceleration of 1m/s<sup>2</sup>.*

#### Example 2.4

A truck of mass 2.5 tonnes accelerate at 7.5 m/s<sup>2</sup>. Calculate the force generated by the truck's engine to attain this acceleration.

**Solution**

$$\begin{aligned} F &= ma \\ &= (2.5 \times 1\,000) \text{ kg} \times 7.5 \text{ m/s}^2 \\ &= 18\,750 \text{ N} \end{aligned}$$

#### Example 2.5

An object of mass 4 kg accelerates to 5 m/s<sup>2</sup>. Calculate the resultant force.

**Solution**

$$\begin{aligned} F &= ma \\ &= 4 \text{ kg} \times 5 \text{ m/s}^2 \\ &= 20 \text{ N} \end{aligned}$$

**Example 2.6**

Calculate the acceleration produced by a force of 20 N on an object of mass 300 kg.

**Solution**

$$a = \frac{F}{m} = \frac{20 \text{ N}}{300 \text{ kg}}$$

$$= 0.0667 \text{ m/s}^2$$

**Example 2.7**

Table 2.2 shows the values of force,  $F$ , and the acceleration,  $a$ , for the motion of a trolley on a friction compensated runway.

Table 2.2

Force $F$ (N)	0.2	0.4	0.6	0.8	1.2
Acceleration, $a$ ( $\text{m/s}^2$ )	0.90	1.8	2.7	3.6	5.4

- (a) Plot a graph of force,  $F$  against acceleration,  $a$ .  
 (b) Use your graph to determine the force when the acceleration is  $4.0 \text{ m/s}^2$   
 (c) Calculate the mass of the trolley, in grams, from your answer in (b).

**Solution**

- (a) The graph is shown in Fig. 2.6.  
 (b) As shown in the graph, force,  $F = 0.9 \text{ N}$ , when acceleration,  $a = 4.0 \text{ m/s}^2$ .  
 (c) Since  $F = ma$ ,  $m = \frac{F}{a}$

$$= \frac{0.9 \text{ N}}{4.0 \text{ m/s}^2}$$

$$= 0.225 \text{ kg}$$

The mass of the trolley = 225 g

**Note:**

The slope of the graph of Force ( $F$ ) against acceleration ( $a$ ) gives the mass of trolley.

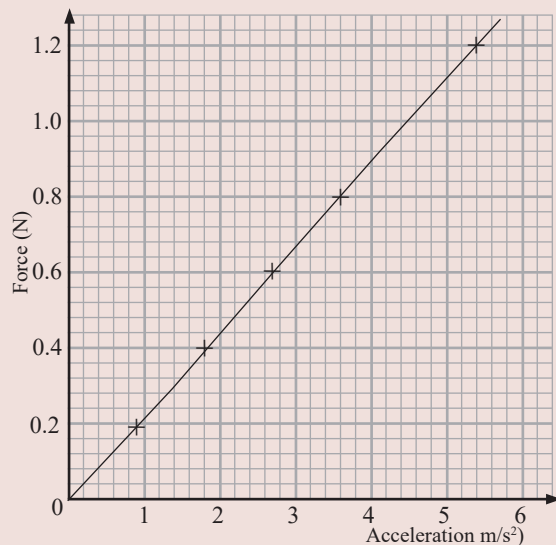


Fig. 2.6: A graph of acceleration against force

**Example 2.8**

A car of mass 1 500 kg is brought to rest from a velocity of 25 m/s by a constant force of 3 000 N. Determine the change in momentum produced by the force and the time it takes the car to come to rest.

**Solution**

$$\begin{aligned} \text{Data: } m &= 1\,500 \text{ kg} & u &= 25 \text{ m/s} \\ v &= 0 \text{ m/s} & F &= 3\,000 \text{ N} \end{aligned}$$

$$\begin{aligned} \text{Change in momentum} &= mv - mu \\ &= (1\,500 \times 0) - (1\,500 \times 25) \\ &= -37\,500 \text{ N s} \end{aligned}$$

*(negative sign show the direction)*

$$\text{Impulse (Ft)} = \text{Change in momentum}$$

$$Ft = 37\,500$$

$$t = \frac{37\,500 \text{ N s}}{3\,000 \text{ N}} = 125 \text{ s or } 2 \text{ min } 5 \text{ seconds}$$

**Exercise 2.2**

- (a) State Newton's second law of motion.

(b) Use Newton's second law of motion to derive the equation  $F = ma$ .

(c) Define the unit of force, 'the newton' using  $F = ma$ .
- (a) What is meant by 'impulse of a force'?

(b) What is the relationship between impulse and the change in momentum?

(c) When a soccer goalkeeper is being trained on how to catch hard balls, he/she is taught how to pull back the hands while catching the ball. Explain how the technique works.
- A 0.06 kg tennis ball drops freely from the left hand of a player. When in the air, it hits a racquet and leaves with a horizontal speed of 58 m/s.

(a) Calculate the impulse produced on the ball.

(b) If the time of contact with the racquet is 0.025 seconds, calculate the average force exerted on the ball.
- A bullet of mass 7 g travels with a velocity of 150 m/s. It hits a target and penetrates into it. It is brought to rest in 0.04 s. Find the:

(a) distance the bullet travels in the target.

(b) average retarding force exerted on the bullet.
- A ball of mass 45 g travelling horizontally at 30 m/s strikes a wall at right angles and rebounds with a speed of 20 m/s. Find the impulse exerted on the ball.

6. Fig. 2.7, shows a graph of the force on a tennis ball when served during a game. Find the mass of the ball if it leaves the racket with a velocity of 40m/s. (Assume the ball is stationary before it is struck.)

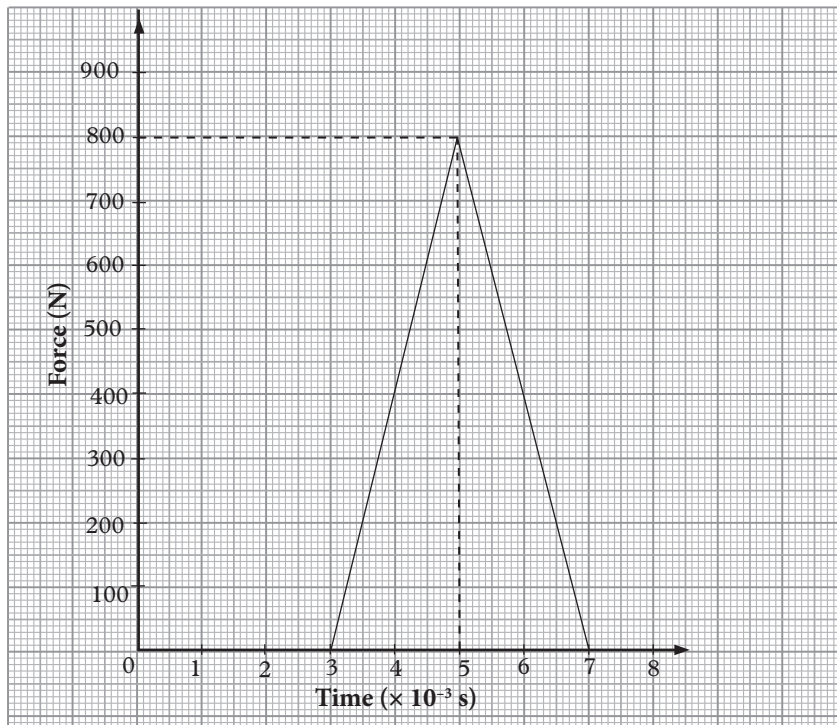


Fig. 2.7: A graph of force against time

7. A truck of mass 4 000 kg starts from rest on a horizontal rails. Find the speed 4 seconds after starting if the impulsive force by the engine is 1 500 N.

## 2.4 Newton's third law of motion

### Activity 2.5

#### To demonstrate action and reaction force

#### Materials

- Carton
- Cello tape
- 4 pins
- A large balloon
- A straw

#### Steps

1. Cut out one rectangular and 4 equal circular pieces from the carton to act as the body and wheels of a trolley.
2. Pass the pins through the centre of the wheels to act as the shafts and fix the pins onto the body using cello tape. Ensure the wheels are able to rotate freely about the shafts.



3. Fix the straw into the mouth of the balloon using the cello tape and seal the mouth airtight. Fix the straw firmly onto the body of the trolley using cello tape as shown in Fig 2.8.
4. Inflate the balloon through the straw and then seal the mouth of the straw with the finger to prevent air from coming out. Place the trolley on a smooth horizontal surface
5. Remove the finger suddenly from the mouth of the straw so that air from the balloon comes out at once (Fig 2.8). Observe what happens to the trolley.

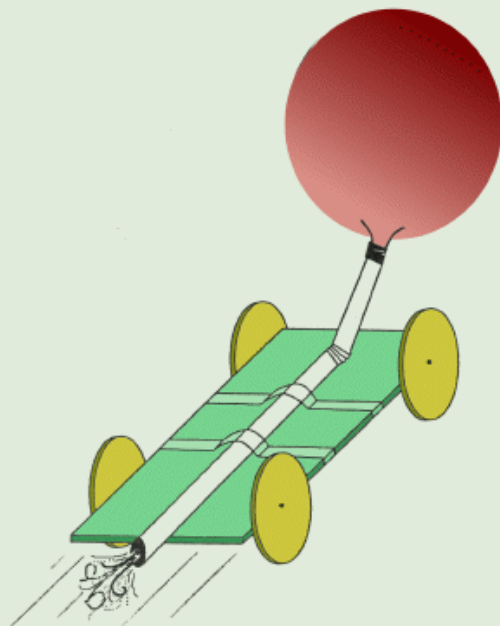


Fig. 2.8: A demonstration of action and reaction

6. In what direction does the air move as it leaves the mouth of the straw? In which direction does the trolley move? Explain the behaviour of the trolley. State the law that governs the behaviour of the trolley and other objects under similar conditions.

It is easier to study effects of forces on an object by considering one force at a time. However, in reality, a single force cannot exist by itself. Two forces always occur when two objects push or pull each other. These forces are called *action* and *reaction* force.

*Newton's third law* of motion states that if a body  $X$  exerts a force on another body  $Y$ ,  $Y$  exerts an equal and opposite force on  $X$ , i.e. to every action force there is an equal and opposite reaction force.

Fig. 2.9 shows a real life example where action and reaction force is experienced.

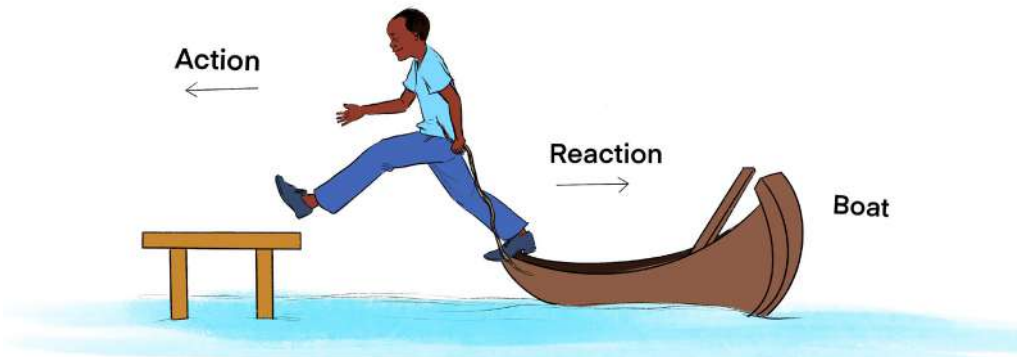


Fig 2.9: A person jumping from a boat

When one jumps off (action force) shore from a boat his/her forward force, exerts a backward force (reaction) on the boat. The boat moves backwards dragging with it his/her legs and then person tends to fall into the water, (see Fig. 2.9).

### Example 2.9

Fig. 2.10 shows a block of mass 4.5 kg resting on a smooth horizontal surface. It is attached to another block of mass 1 kg using a light inextensible string passing over a frictionless pulley.

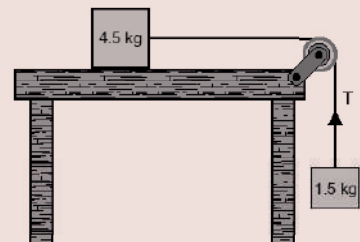


Fig. 2.10: Mass system over a pulley

Determine

- The acceleration of the system.
- The tension in the string.

### Solution

- The weight of the 1.5 kg block ( $1.5 \times 10 = 15 \text{ N}$ ) acting downwards makes the two blocks to move together as one block of mass of 6 kg (i.e  $1.5 + 4.5 = 6 \text{ kg}$ ). There is no frictional force hence this weight is the resultant force

Resultant force = mass  $\times$  acceleration

$$15 \text{ N} = (1.5 + 4.5) \text{ kg} \times a$$

$$\text{Acceleration, } a = \frac{15 \text{ N}}{6 \text{ kg}} = 2.5 \text{ m/s}^2$$

- Let the tension in the string be T. Since the block is accelerating downwards, weight of the 1.5 kg block is greater than tension T.

The resultant force acting downwards is  $(15 - T)$  N.

Resultant force = mass  $\times$  acceleration

$$15 \text{ N} - T = 1.5 \times 2.5$$

$$\text{Tension } T = 15 \text{ N} - 3.75 \text{ N} = 11.25 \text{ N}$$

### Exercise 2.3

1. Give three real life situations where Newton's third law of motion is experienced.
2. In groups, discuss the working principle of the following:-

- (a) Rockets and jet propulsion
- (b) The garden sprinklers

3. A garden sprinkler (Fig. 2.11) has three of the four jets blocked.  $60 \text{ cm}^3$  of water jets out of the fourth jet every second (density of water is  $1 \text{ g/cm}^3$ ). If the area of the mouth of the jet is  $15 \text{ mm}^2$ , find:

- (a) the velocity of the water coming out.
- (b) the minimum force required to prevent rotation.
- (c) Explain how you would, measure the force in (b).

4. A rocket pushes out exhaust gas at a rate of  $150 \text{ kg/s}$ . The velocity of the gas is  $250 \text{ m/s}$ . Calculate the forward thrust on the rocket.
5. A block of mass  $8 \text{ kg}$  rests on a smooth horizontal surface. It is being dragged by another block of mass  $2 \text{ kg}$  attached to it by a light in extensible string passing over a frictionless pulley.

- (a) Draw the setup described above.
- (b) Calculate the acceleration of the system.
- (c) Calculate the tension in the string.

6. Stunt men in films often fall safely from tall buildings.

- (a) Two main forces act on such a man when falling. Name these forces.
- (b) To reduce chances of injury, such a man usually lands on deep soft, inflatable mattresses placed at the landing point. Explain how the mattresses achieve this purpose.

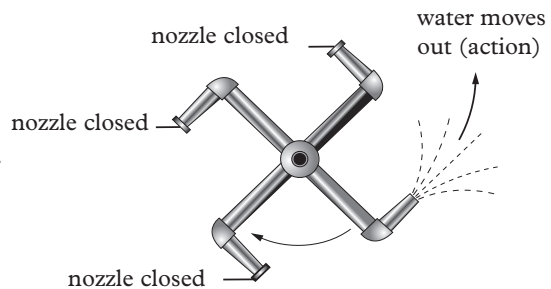


Fig. 2.11: sprinkler moves back (reaction)

## 2.5 Conservation of linear momentum

### 2.5.1 Law of conservation of momentum

#### Activity 2.6

To demonstrate the conservation of linear momentum

#### Materials

- A table
- Marbles

#### Steps

1. Place the marbles a distance from each other on table in a straight line.  
(See Fig. 2.12)

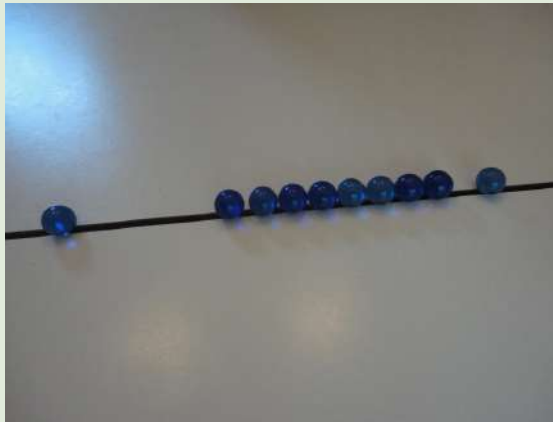


Fig. 2.12: Marbles arranged in a straight line

2. Strike the one near you towards the next. What did you observe about their movement after collision? Explain.

Suppose two objects A and B of masses  $m_A$  and  $m_B$  move in the same direction with different velocities (See fig. 2.13). And there are no other external unbalanced force acting on them.



Fig. 2.13: Collisions

On collision, A pushes B with a force  $F_A$  and B reacts by pushing A with an equal and opposite force  $F_B$ . Such that  $F_A = -F_B$ .

Since the time spent in colliding is the same, A experiences an impulse  $-F_B t$  from B while B also experiences an impulse  $F_A t$  from A.

Thus  $-F_B t = F_A t \dots\dots$  (i)

*Impulse = change in momentum =  $mv - mu$*

Letting the final velocities of A and B be  $v_A$  and  $v_B$  respectively

Then,  $-F_B t = m_A v_A - m_A u_A \dots\dots$  (ii)

$F_A t = m_B v_B - m_B u_B \dots\dots$  (iii)

Equating (ii) and (iii)

$$-(m_A v_A - m_A u_A) = m_B v_B - m_B u_B$$

$$-m_A v_A + m_A u_A = m_B v_B - m_B u_B$$

$$m_A u_A + m_B u_B = m_A v_A + m_B v_B$$

But  $m_A u_A + m_B u_B =$  total momentum before collision

and  $m_A v_A + m_B v_B =$  total momentum after collision

*$\therefore$  Total momentum before collision = total momentum after collision*

The momentum has been conserved. This conclusion is summarised as the law of conservation of momentum.

The *law of conservation of momentum* states that *when two or more bodies collide, their total momentum remains constant provided no external forces act on them.*

## 2.5.2 Collisions

There are two types of collisions, namely *elastic* and *inelastic* collision.

### 2.5.2.1 Elastic collisions

When the total kinetic energy is conserved after collision, the collision is said to be *elastic*. This is only possible between atoms or molecules. However, the collision between two smooth marble balls is approximately elastic.

### Activity 2.7

### To demonstrate an elastic collision

#### Materials

- Two trolleys A and B
- A tape
- Different masses (200 g and 300 g)
- A ticker timer
- Weighing balance
- Two carbon papers
- A runway

#### Steps

1. Determine the mass of trolleys A and B. Compensate the runway for friction.
2. Attach a tape to each of the trolleys. Pass the two tapes through a ticker timer using two carbon papers (Fig. 2.14).

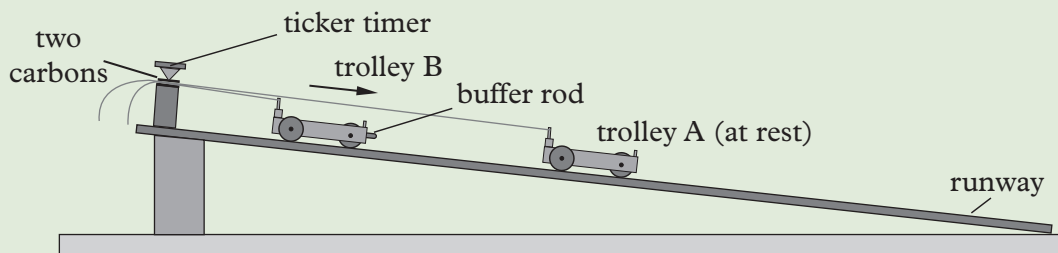


Fig. 2.14: Elastic collision

3. Position trolley A halfway down the runway. Make sure it is stationary.
4. Start the ticker timer and push trolley B aiming its buffer rod towards the trolley A.
5. Allow the two trolleys to continue moving after the collision.
6. Calculate from the tapes, the velocity of trolley B before collision  $u_B$  and the velocity of trolley A and B after collision ( $v_A$  and  $v_B$ ).
7. Repeat the experiment with trolleys A and B loaded with different masses. Record the results in a table (Table 2.3).
8. Determine the total momentum and the total kinetic energy before and after collision. Compare their values before and after collision.

Table 2.3

Before collision				After collision								
Trolley A	Trolley B		Total momentum	Total K.E	Trolley A	Trolley B		Total momentum	Total K.E			
$m_A$	$u_A$	$m_A u_A$	$m_B u_B$	$m_B u_B$	$m_A u_A + m_B u_B$	$\frac{1}{2} m_A u_A^2 + \frac{1}{2} m_B u_B^2$	$m_A v_A$	$m_A v_A$	$m_B v_B$	$m_B v_B$	$m_A v_A + m_B v_B$	$\frac{1}{2} m_A v_A^2 + \frac{1}{2} m_B v_B^2$

The results of a similar activity shows the tapes shown in Fig. 2.15.

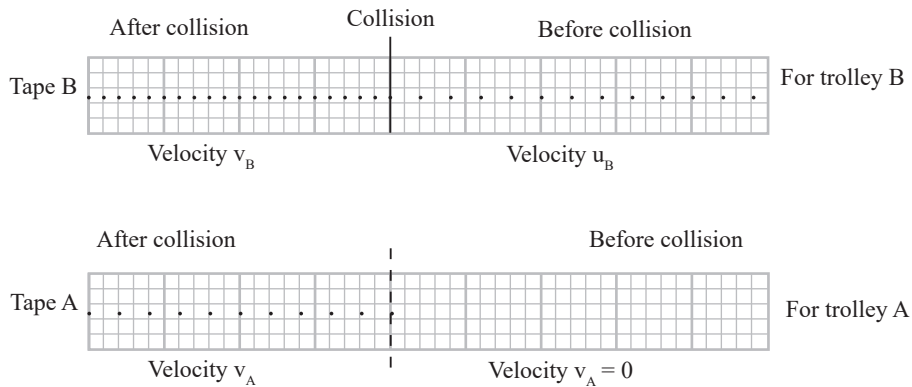


Fig. 2.15: Ticker timer tapes

If no other forces are acting, the total momentum and total energy before and after collision is found to be the same. These types of collisions are not common because in every collision, some energy is always converted to other forms. (Tell your classmates which other forms?)

### Example 2.10

A cannon of mass 800 kg fired a cannon ball of mass 3 kg at a velocity of 120 m/s. Find the recoil velocity of the cannon.

#### Solution

$m_1 = 3 \text{ kg}$ ,  $u = 0 \text{ m/s}$ ,  $v_1 = 120 \text{ m/s}$ ,  $m_2 = 800 \text{ kg}$ ,  $u_2 = 0$ ,  $v_2 = ?$

Total initial momentum = total momentum

$$m_1 u_1 + m_2 u_2 = m_1 v_1 + m_2 v_2$$

$$3 \times 0 + 800 \times 0 = 3 \times 120 + 800 \times v_2$$

$$0 = 360 + 800v_2$$

$$-800v_2 = 360$$

$$v_2 = -\frac{360}{800} = -0.45 \text{ m/s}$$

The cannon recoiled backwards at a velocity of 0.45 m/s. The negative value in the velocity shows that the cannon moved (recoiled) in the opposite direction.

### 2.5 2.2. Inelastic collision

#### Activity 2.8

To demonstrate inelastic collision

#### Materials

- Two trolleys A and B
- A cork
- A pin or a sharp buffer rod
- Masses 200 g, 300 g
- Runway
- A weighing balance

#### Steps

1. Determine the mass of two trolleys A and B. Raise the runway to compensate for friction.
2. Attach a cork at the back of trolley A. Position trolley A halfway down the runway. Make sure it is stationary.
3. Attach a pin or a sharp buffer rod at the front of trolley B and a tape to pass through the ticker timer.
4. Start the ticker timer. Push the trolley B aiming the pin towards the cork on trolley A (Fig. 2.16).

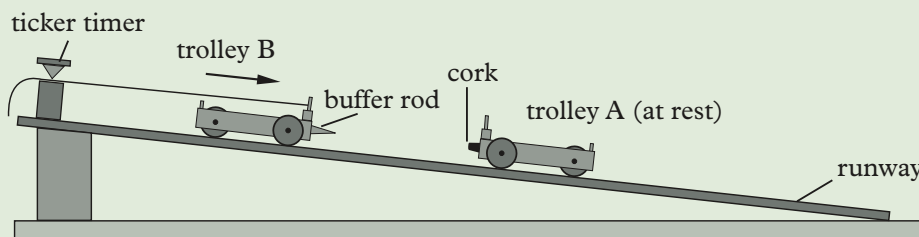


Fig. 2.16: Setup to demonstrate inelastic collision

5. Allow the trolleys to move together after collision.
6. Repeat the experiment with trolleys A and B loaded with different masses. Record the results in a table (Table 2.4).
7. Determine the total momentum and the total kinetic energy before and after collision. Compare these quantities before and after collision.
8. Record your results in a tabular form as shown in table 2.4.

Table 2.4

Before collision					After collision			
Trolley B			Total momentum	K.E			Total momentum	Total K.E
$m_B$	$u_B$	$m_B u_B$	$m_B u_B$	$\frac{1}{2} m_B u_B^2$	$m_{AB}$	$v_{AB}$	$m_{AB} v_{AB}$	$\frac{1}{2} m_{AB} v_{AB}^2$



9. From the tapes, measure the velocity ( $u_B$ ) of trolley B before collision, and then velocity ( $v_{AB}$ ) of trolley A and B after collision. Comment on your answer.

A similar activity that was conducted by some students produced the tapes shown in Fig. 2.17.

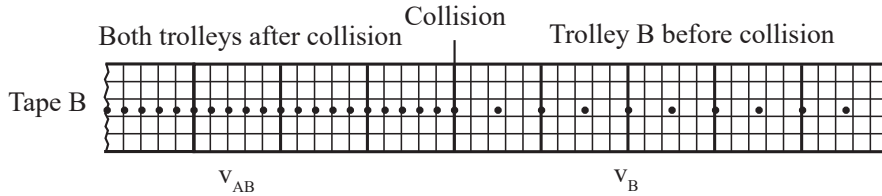


Fig. 2.17: Ticker timer tape

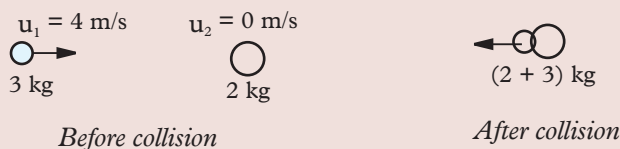
From the tape, we observed that during the collision only momentum is conserved, but there is a loss of kinetic energy.

We have seen that when the two bodies collide, their total momentum is conserved. The total kinetic energy is however not usually conserved. Some kinetic energy is converted into sound and heat. Collisions where the total kinetic energy is not conserved are called *inelastic collisions*. A *completely inelastic* collision is one *which two bodies stick together after collision*.

### Example 2.11

A mass of 3 kg moving with a velocity of 4 m/s collides with another mass of 2 kg which is stationary. After collision the two masses stick together. Calculate the common velocity for the two masses after collision.

#### Solution



$$\begin{aligned}\text{Momentum before collision} &= m_1 u_1 + m_2 u_2 = (2 \times 0) + (3 \times 4) \\ &= 12 \text{ kg m/s}\end{aligned}$$

$$\text{Momentum after collision} = (m_1 + m_2)v = (3 + 2)v = 5v$$

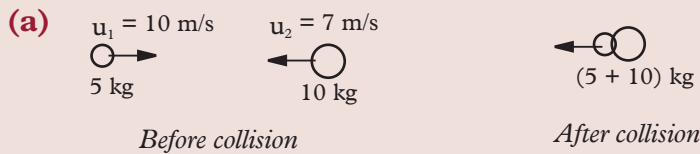
$$\text{Momentum before collision} = \text{momentum after collision}$$

$$12 \text{ kg m/s} = 5v$$

$$\therefore \text{Common velocity, } v = 2.4 \text{ m/s}$$

**Example 2.12**

A 5 kg mass moving with a velocity of 10 m/s collides with a 10 kg mass moving with a velocity of 7.0 m/s along the same line. If the two masses join together on impact, find their common velocity if they were moving: **(a)** in opposite direction **(b)** in the same direction

**Solution**

Velocity of 5 kg mass = +10 m/s ; velocity of 10 kg mass = -7 m/s

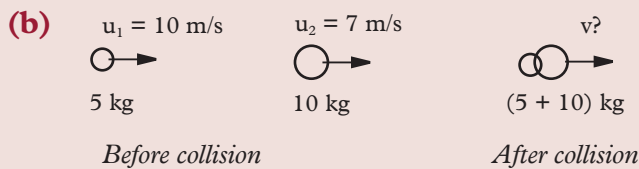
Momentum before collision = momentum after collision

$$(5 \times 10) + (10 \times -7) = (5 + 10)v$$

$$50 + (-70) = 15v$$

$$v = -1.33 \text{ m/s}$$

The minus sign means that the joined mass moves in the initial direction of the 10 kg mass.



Momentum before collision = momentum after collision

$$(5 \times 10) + (10 \times 7) = 15 \times v$$

$$50 + 70 = 15v$$

$$v = +8.0 \text{ m/s}$$

The plus sign means that the joined mass move in the initial direction of the two individual masses.

**Exercise 2.4**

- A mass of 8 kg travelling to the right at 2.5 m/s collides with a 2 kg mass travelling to the left at 3.0 m/s. Find
  - the momentum of each mass.
  - their total momentum.
- An object of mass 20 kg collides with a stationary object of mass 10 kg.

The two objects join together and move at a velocity of 5 m/s. Find the initial velocity of the moving object.

3. A car of mass 600 kg travels at 20 m/s towards a stationary pick-up of 1 200 kg. After colliding, the two stick and move together. Find their common velocity.
4. A truck of mass 3 000 kg moving at 3 m/s collides head on with a car of mass 600 kg. The two stop *dead* on collision. At what velocity was the car travelling before collision?
5. If a 2 kg ball travelling north at 6 m/s collides with 4 kg ball travelling in the same direction at 4 m/s, the velocity of the 4 kg ball is increased to 5.5 m/s to the north. What happens to the 2 kg ball?
6. A small car of mass 500 kg is involved in a head-on collision with a heavy car of mass 4 000 kg travelling at 20 m/s. The small car is thrown onto the bonnet of the heavy car which continues after impact at 4 m/s in the original direction. How fast was the small car moving?
7. A bullet of mass 10 g is shot from a gun of mass 20 kg with a muzzle velocity of 100 m/s. If the barrel is 20 cm long, determine:
  - (a) the acceleration of the bullet.
  - (b) the recoil velocity of the gun.

## 2.6 Coefficient of friction

In Senior 1, we were introduced to frictional force. We defined friction as the force that oppose the relative motion of two surfaces that are in contact. In Senior 2, we also learnt that the two factors that affect the friction between two surfaces are the nature of the surfaces and the normal reaction (R).

In this section, we will learn how to determine the coefficient of friction between two surfaces.

### 2.6.1 Determination of coefficient of friction

#### Activity 2.9

To describe motion of object on a horizontal plane with or without friction

#### Materials

- A solid block
- Spring balance
- Smooth and rough horizontal surfaces

#### Steps

1. Attach the spring balance to the solid block.
2. Pull the solid block across the rough surface through a particular distance. Record the force applied.

3. Repeat step 2 but this time on a smooth surface. Compare the two forces recorded. What do you observe? Which surfaces was easier to move the block? Explain.

Look at Fig. 2.18. A solid block is being pulled over a horizontal surface by an applied force,  $F$ . Frictional force ( $F_r$ ) acts in the opposite direction to oppose the movement of the block.

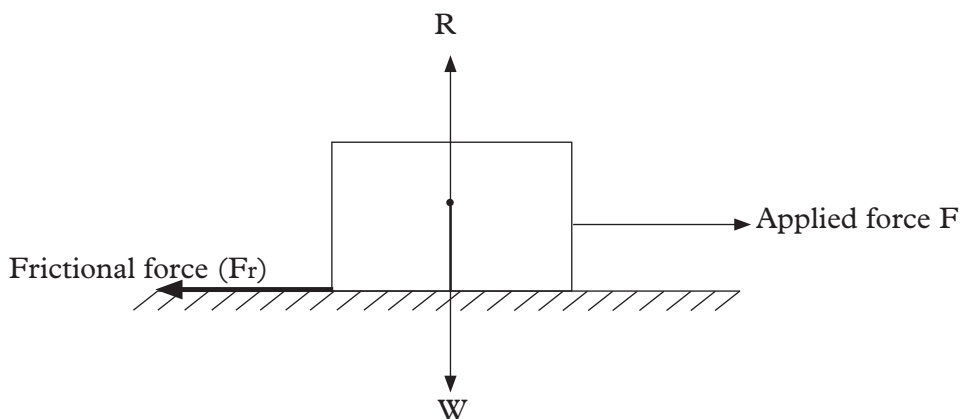


Fig. 2.18: Forces acting on a solid block on a horizontal surface

When the block is just about to move, solid friction between the block and the surface is called *static friction*. Static friction is the force opposing motion between surfaces when the surfaces are just about to move. When the block is moving, friction force is reduced and is called *dynamic friction*. Dynamic friction is the opposing force to motion when there is relative motion between surfaces.

Suppose some weights are placed on top of the block, would the frictional force remain the same? In other words, what is the relationship between the frictional force and the normal reaction ( $R$ )?

The following experiment will help us establish the relationship between frictional force and normal reaction.

### Activity 2.10

To establish the relationship between frictional force and normal reaction

#### Materials

- A 50 g wooden block with rough surface.
- Four 50 g mass
- A rough bench
- A spring balance

**Steps**

1. Set up the apparatus as shown in Fig. 2.19.

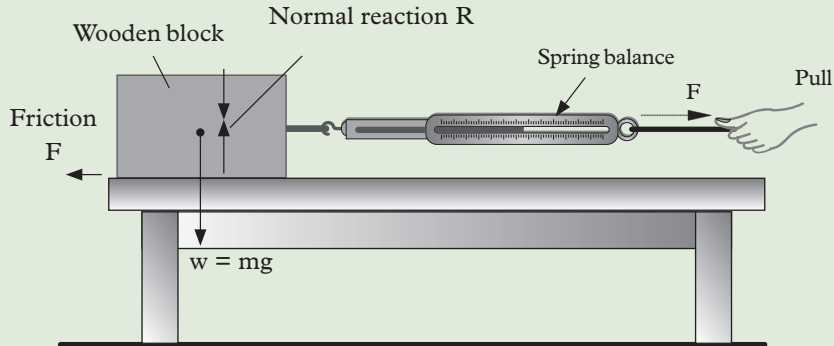


Fig. 2.19: Determining coefficient of friction

2. Pull the string until the block is just about to move. Record the reading on the spring balance.

Note that the spring balance reads the value of frictional force which is acting in the opposite direction in this experiments. ( $F$  is the frictional force between the surfaces.

Frictional force = Applied force  $F$ ).

3. Place one 50 g mass on the block and pull the string again. Record the reading on the spring balance.
4. Repeat steps 2 and 3 for two, three and four 50 g masses on the block masses and the record the reading of force,  $F$  on the spring balance in Table 2.5.

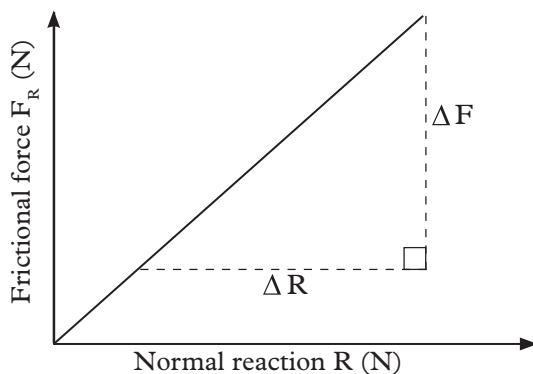
Table 2.5

Mass (g)	50	100	150	200	250
Reaction $R$ (N)					
Spring reading ( $F$ ) (N)					

5. Draw a graph of  $F(N)$  against  $R(N)$ .

The results from a similar activity showed that the readings on the spring balance increase with the increase of mass. When a column of  $\frac{F}{R}$  was added and completed in the table, it was noted that the value of  $\frac{F}{R}$  was constant.

When a graph of  $F$  against  $R$  was plotted, a straight line that is passes through the origin was obtained (Fig. 2.20).

Fig. 2.20: A graph of  $F$  against  $N$ 

The gradient of the line gives:

$$\text{Gradient} = \frac{\text{change in } F}{\text{change in } R} = \frac{\Delta F}{\Delta R}$$

From the graph (Fig. 2.19), we conclude that, frictional force opposing the movement of a solid is directly proportional to the weight of the solid i.e.  $F \propto W$ .

From Newton's third law of motion:

Weight ( $w$ ) of an object placed on the bench is equal and opposite to the normal reaction ( $R$ ) between the surface of the bench and the block in contact.

Frictional force,  $F \propto w$

Therefore,  $F \propto$  Normal reaction ( $R$ ) (i.e.  $F \propto R$ )

Therefore,  $F = \mu R$ , where  $\mu$  is a constant called the **coefficient of friction**.

As we have already learnt, the solid friction force is either static or kinetic friction depending on the state of motion of the solid.

(a) The **coefficient of static friction**,  $\mu_s$ , is the ratio of static frictional force to the normal reaction  $R$ .

$$\mu_s = \frac{F}{R}$$

**Coefficient of static friction**,  $\mu_s$ , has no unit since it is a ratio of forces.

One has to apply a force larger than the limiting **static frictional force** ( $F_s$ ) for a body to move.

(b) When the body is sliding along the bench with a constant velocity, the frictional force is now called **kinetic or dynamic friction** ( $F_k$ ). It is calculated as  $F_k = \mu_k R$ , where  $R$  is the normal force and  $\mu_k$  is the coefficient of kinetic friction.

**Example 2.13**

A force of 25 N just limits the motion of a block of mass 50 kg which is being dragged on the horizontal ground. Calculate the coefficient of static friction force.

**Solution**

$F_s = \mu_s R$  where  $\mu_s$  is the coefficient of static friction

Weight of the block = Normal reaction =  $50 \text{ kg} \times 10 \text{ N/kg} = 500 \text{ N}$

$$F_s = \mu_s R$$

$$\therefore 25 \text{ N} = \mu_s \times 500 \text{ N}$$

$$\mu_s = \frac{25 \text{ N}}{500 \text{ N}} = 0.05$$

$$\mu_s = 0.05$$

**Example 2.14**

Fig. 2.21 shows a block of mass 200 kg being dragged at constant velocity with a force 40 N at angle  $60^\circ$  to the horizontal.

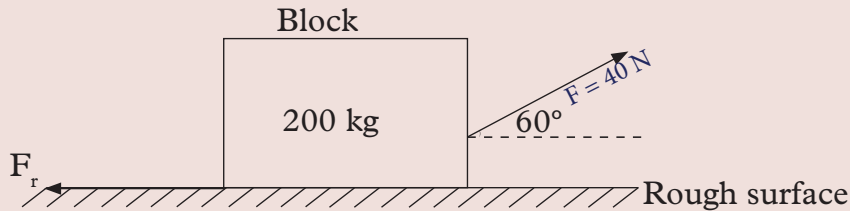


Fig. 2.21: A block being dragged at a constant velocity horizontally

Determine the coefficient of kinetic friction ( $\mu_k$ ).

**Solution**

$$F_r = \mu_k R$$

Since the body is not accelerating,

Friction = horizontal component of F.

$$F_r = F_h = F \cos \theta = 40 \times \cos 60 = 40 \times 0.5 = 20 \text{ N}$$

$$R = \text{Weight} - \text{vertical component of } 40 \text{ N}$$

$$= 2000 \text{ N} - 40 \sin 60^\circ$$

$$= 1965.36 \text{ N}$$

Substituting for  $F_r$  and R in,  $F_r = \mu_k R$ , we get:

$$20 \text{ N} = \mu_k \times 1965.36 \text{ N}$$

$$\mu_k = \frac{20 \text{ N}}{1965.36 \text{ N}} = 0.01$$

The coefficient of kinetic friction is 0.01.

### Unit summary and new words

- Newton's first law of motion states that a body continues in its state of rest or uniform motion in a straight line unless compelled to act otherwise by some external force.
- Momentum is the product of mass and velocity of a body.

$$(p = m \times v)$$

- Impulse = force (N)  $\times$  time(s) = Ft
- Impulse = change in momentum (**Ft = mv - mu**)
- Newton's second law of motion states that the rate of change of momentum is directly proportional to the force on a body and takes place in the direction in which the force acts.
- $F = ma$  is the mathematical statement of Newton's second law of motion.
- The law of conservation of momentum states that when one or more bodies collide, their total momentum remain constant provided no external forces are acting.

$$\mathbf{m_A u_A - m_B u_B = m_A v_A - m_B v_B}$$

- In an elastic collision, the bodies separate after colliding. Both momentum and kinetic energy are conserved.
- In an inelastic collision, the bodies fuse and move together after colliding. Momentum is conserved but kinetic energy is not.
- Newton's third law states that for every action there is an equal and opposite reaction.
- Frictional force by solid is directly proportional to the normal reaction (R) of the solid, that is,

$$F \propto R$$

Therefore,  $F = \mu R$  where  $\mu$  is called coefficient of friction

- There are two kind of friction force; static and kinetic.



The coefficient of static friction is given by

$$\mu_s = \frac{F}{R}$$

While the coefficient of kinetic dynamic friction is given by

$$\mu_k = \frac{F}{R_k}$$

## Unit Test 2

For questions 1 - 5, select the most appropriate answer.

- The following are factors affecting inertia of a body, which one is not?
 

**C** Acceleration of body                      **B.** Linear momentum  
**C.** Mass of a body                                **D.** Friction acting on a body
- Which one of the following is the correct definition of momentum?
 

**C** Sum of two forces acting on a body.  
**B.** Product of mass and density of a body.  
**C.** Product of mass and velocity of a body.  
**D.** Product of impact and velocity of a body.
- Which one of the following statements is true about inelastic collision?
 

**A.** Momentum and kinetic energy are both conserved.  
**B.** Momentum is conserved but kinetic energy is not.  
**C.** Momentum is not conserved but kinetic energy is conserved.  
**D.** Both momentum and kinetic energy are not conserved.
- Frictional force by a solid is directly proportional to the area of surfaces in contact.
 

**A.** True    **B.** False
- There are more than two states of friction force between solids.
 

**A.** True    **B.** False
- (a) Explain why Newton's first law is also called the law of inertia.  
 (b) Describe an experiment to illustrate the Newton's first law of motion.
- Table 2.6 shows the values of the resultant force,  $F$ , and time,  $t$ , for a bullet travelling inside the gun barrel after the trigger is pulled.

Table 2.6

Force (N)	360	340	300	240	170	110
Time ( $10^{-3}$ s)	3	4	8	12	17	22

- (a) Plot a graph of force,  $F$ , against time,  $t$ .
- (b) Determine from the graph.
  - (i) the time required for the bullet to travel the length of the barrel. (Assume that the force becomes zero just at the end of the barrel).
  - (ii) the impulse of the force.
- (c) Given that the bullet emerges from the muzzle of the gun at a velocity of 240 m/s, calculate the mass of the bullet.

8. A block of mass of 3 kg is pulled by a spring balance that records a force of 10 N. The ticker tape (Fig. 2.22) attached at the back of the mass shows a group of 10 spaces between them having the lengths as shown in Fig 2.22. The ticker timer makes 50 dots per second.

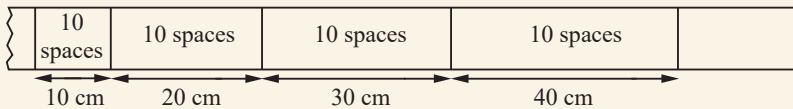


Fig. 2.22

- (a) Draw and show how the dots are spaced out on the tape.
  - (b) Find
    - (i) the acceleration of the block
    - (ii) the balanced force acting on the block.
9. The graph in (Fig. 2.23) shows how the force applied on a 20 kg mass varies with time.

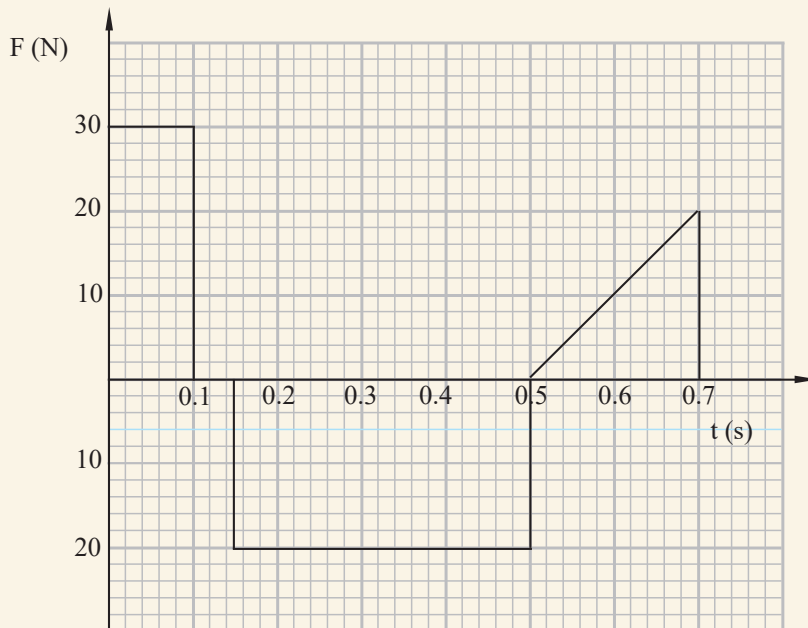


Fig. 2.23: A graph of  $F$  against  $t$

- (a) Find the total impulse after 0.7 s.
- (b) If the body starts from rest, draw the:
- acceleration-time graph.
  - velocity-time graph.
  - momentum-time graph.
10. A ball of mass of 2.0 kg, travelling at 1.5 m/s collides with another ball of mass 3.0 kg travelling at 0.8 m/s in the same direction. If they stick and move together, calculate.
- the common velocity after collision.
  - the change in momentum for each ball.
11. A rugby player of mass 75 kg, running east at 8.0 m/s, collides with another player of mass 90 kg and who is running directly towards him at 5.0 m/s. If the two players cling together after the tackle, what will be their common velocity?
12. Fig. 2.24 is a graph of acceleration against applied force.

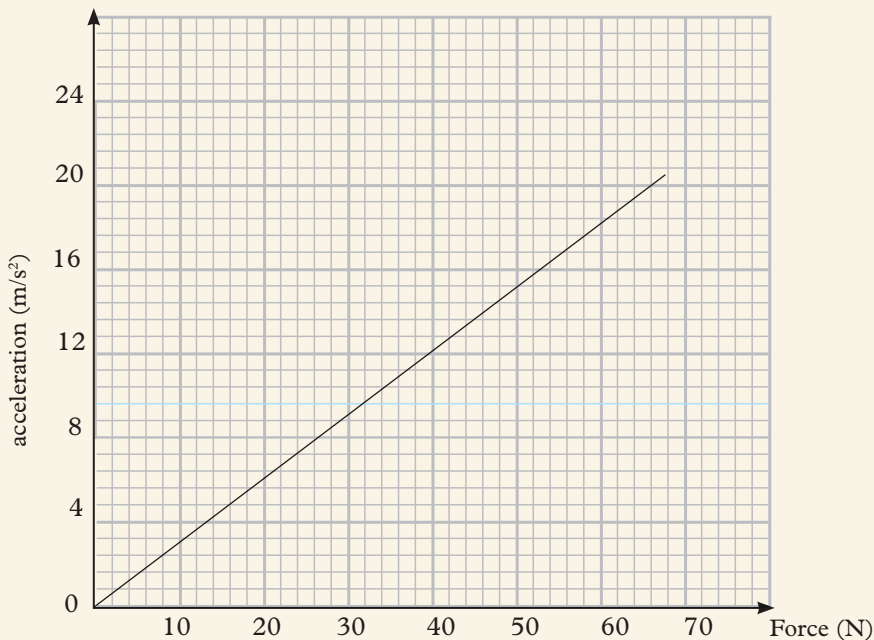


Fig. 2.24 A graph of acceleration against force

Find:

- the force that results in an acceleration of 14 m/s<sup>2</sup>.
- the gradient and state its unit.

- 13.** A bullet of mass 15 g travelling at 400 m/s becomes embedded onto a block of wood of mass 300 g which is at rest. Calculate the initial speed of the block immediately after collision.
- 14.** A bullet of mass 20 g travelling horizontally at a speed of 200 m/s embeds itself in a block of wood of mass 850 g suspended from a light inextensible string so that it can swing freely. Find the:
  - (a)** velocity of the bullet and block immediately after collision.
  - (b)** height through which the block rises.
- 15.** Two ice hockey players travelling in opposite directions get entangled and move while locked together. Player A has a mass of 120 kg and is travelling at 5 m/s. Player B has a mass of 90 kg and is travelling at 4 m/s. Calculate.
  - (a)** the initial momentum of player A.
  - (b)** the initial momentum of player B.
  - (c)** the speed with which they both move with after being locked together.
  - (d)** In which direction did they move after collision?
- 16.** A trolley of mass 2 kg travelling from left to right at 4 m/s collides elastically with another trolley of mass 4 kg travelling from right to left at 1 m/s. If the speed of the 2 kg trolley after collision is 0.8 m/s, what is the speed of the 4 kg trolley?
- 17.** A block weighing 400 N is pushed along a surface. If it takes 110 N to get the block moving and 70 N to keep the block at a constant velocity, what are the coefficient of friction  $\mu_s$  and  $\mu_k$ ?
- 18.** State:
  - (a)** three advantages of frictional force
  - (b)** three disadvantages of frictional force
- 19.** A force  $F$  pushes towards the left on a box. A friction force,  $f$ , between the floor and the box resists the movement of the box. These are the only forces acting in the horizontal direction. For the following three cases, state which is bigger (or the same size),  $F$  or  $f$  and why.
  - (a)** The box does not move.
  - (b)** The box moves to the left with constant velocity.
  - (c)** The box moves to the left and accelerates.
  - (d)** The box moves to the left and decelerates

## UNIT

## 3

# Applications of Atmospheric Pressure

## Key Unit Competence

By the end of the unit the learner should be able to explain the existence of pressure in in fluids (gases and liquids) and the application of atmospheric pressure.

## Learning objectives

### Knowledge and understanding

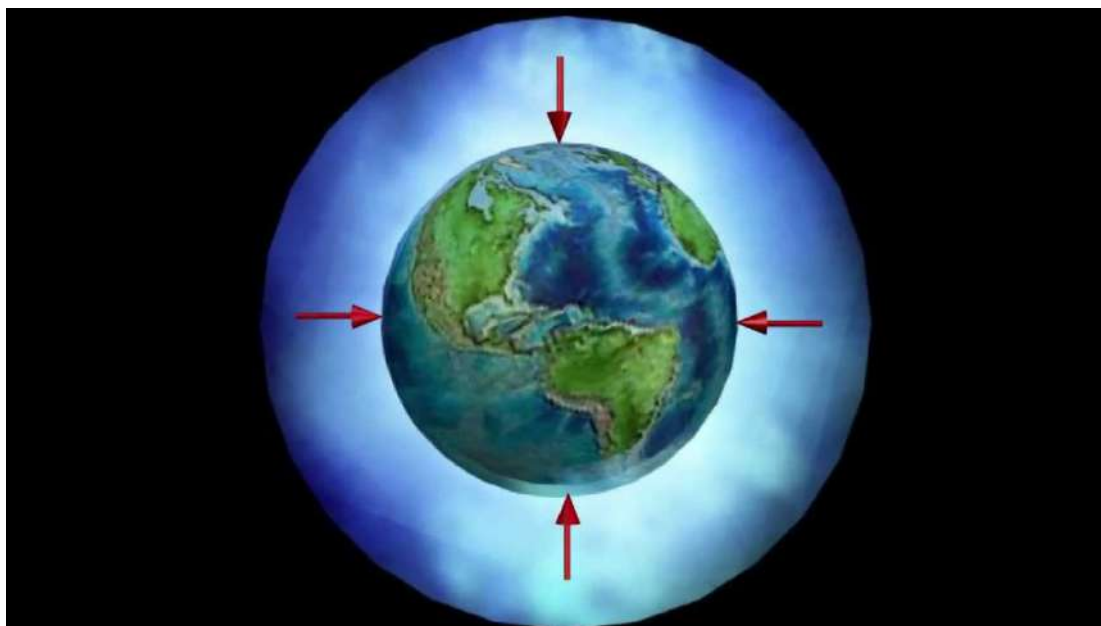
- Explain the existence of force exerted by air on a surface.
- Explain the relationship between atmospheric pressure and altitude.
- Relate atmospheric pressure, density of air and altitude.
- Outline the applications of atmospheric pressure

### Skills

- Explain the force atmospheric pressure exerts on earth surface.
- Discuss factors affecting atmospheric pressure.
- Explain applications of atmospheric pressure in real life.
- Evaluate factors influencing atmospheric pressure.

### Attitude and value

- Appreciate existence of atmospheric pressure.
- Predict change in weather by observing changes in atmospheric pressure.
- Be aware of effects of changing of atmospheric pressure on human body as the altitude increases (climbing mountains).



## Introduction

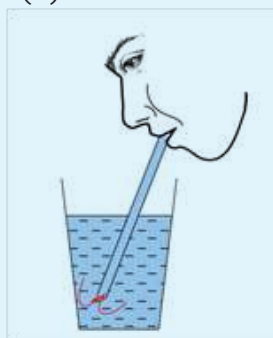
### Unit Focus Activity

#### Materials

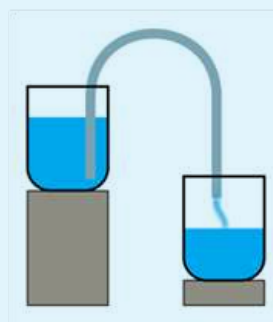
- A glass
- Two beakers
- A straw
- Delivery tube
- Water

#### Steps

1. Put some clean water in a glass. Insert the straw and start drinking through the straw (Fig. 3.1 (a)).
2. Using two beakers, delivery tube and water, setup a working siphon as shown in Fig. 3.1 (b).



(a)



(b)

Fig. 3.1 Some applications of atmospheric pressure

3. Define atmospheric pressure.
4. Explain the application of atmospheric pressure in the working of:
  - (a) drinking straw
  - (b) siphon
5. Identify two more applications of atmospheric pressure.

Atmospheric pressure is the pressure resulting from the weight of the air column acting on the earth's surface. In this unit, we will start by carrying out activities to demonstrate the existence of atmospheric pressure, discuss factors influencing the pressure, instruments used to measure the pressure then discuss the application of atmospheric pressure.

### 3.1 Existence of atmospheric pressure

#### Activity 3.1

To illustrate the existence of atmospheric pressure using an inverted glass tumbler

#### Materials

- A glass tumbler with water
- A cardboard

#### Steps

1. Fill a glass tumbler with water and cover the top with a cardboard (Fig. 3.2(a)).
2. Invert the tumbler while holding the cardboard (Fig. 3.2(b)). Suddenly remove the hand holding the cardboard. What do you observe?
3. Now, turn the tumbler side ways (Fig. 3.2(c)). What do you observe?
4. Suddenly remove the cardboard covering the tumbler. What happens to the water inside the tumbler? Explain.

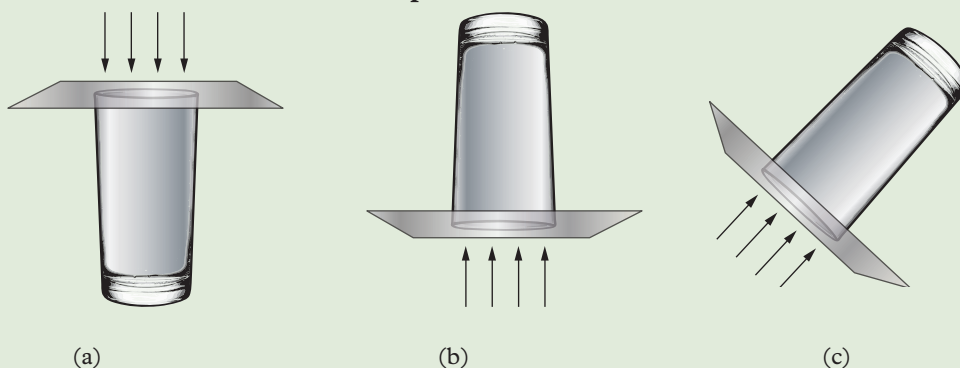


Fig. 3.2: Demonstrating atmospheric pressure using a glass tumbler

You should have observed that the cardboard does not fall when the glass is inverted vertically upwards or sideways. This takes place because the pressure due to the column of air in the atmosphere (i.e. atmospheric pressure) is greater than the combined pressure due to the column of water and air inside the glass. Hence atmospheric pressure keeps the cardboard intact. The water does not flow out.

### Activity 3.2

To illustrate the existence of atmospheric pressure using a can

#### Materials

- A thin-walled can
- Water
- A cork
- Source of heat

#### Steps

1. Pour some water in a large thin-walled can.
2. Boil off the water in the can and immediately cork the can.
3. Allow it to cool and observe what happens.
4. Explain your observations to other group members.

Before the can in this activity is heated and corked, the air inside and outside the can exerts pressure equally on the walls of the container that balances with atmospheric pressure (Fig. 3.2(a)).

When the can is heated (Fig. 3.3 (b)), the steam that is formed expels the air inside the can. After cooling the can, the steam condensed and a partial vacuum is formed inside (Fig. 3.3 (c)). The air pressure inside the can decreases. The atmospheric pressure acting on the surface of the can from outside is greater than the air pressure inside. It therefore makes the can to crust or collapse inward as shown in Fig. 3.3 (c).

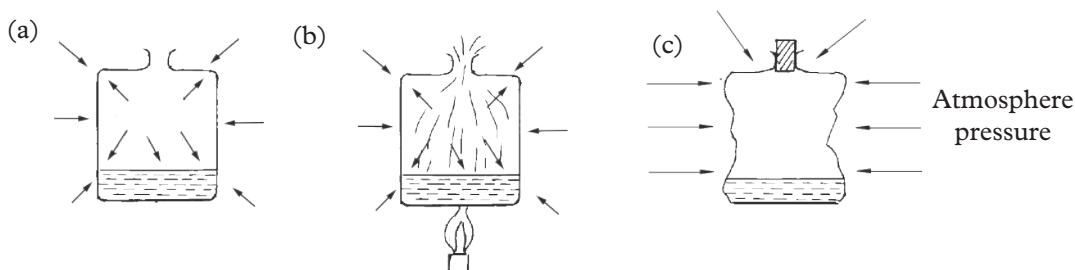


Fig. 3.3: Demonstration of atmospheric pressure



**Activity 3.3**

**To demonstrate existence of atmospheric pressure using a wet coin.**

**Materials**

- A coin
- bench
- Water

**Steps:**

1. Place a coin on top of a bench. Lift it and note the ease with which you do that.
2. Now, wet the bench surface and the coin also. Place the coin on the wet surface.



(a) Lifting a dry coin from table top



(b) Lifting a wet coin from table top

Fig. 3.4: Demonstrating atmospheric pressure by lifting a coin.

3. Lift the coin up, note the ease with which you do that this time round? Explain clearly your observation.
4. Compare your observations on steps 1 and 3. Explain the difference in the two observations.

The water between the coin and the bench expels air, reducing the air pressure under the coin. The atmospheric pressure above the coin presses it to the bench, making it more difficult to lift the coin.

Activities 3.1 to 3.3 shows the existence of atmospheric pressure. This atmospheric pressure plays an important role in our daily lives as we shall learn later in this unit.

**Exercise 3.1**

In groups of three, conduct a research from the internet and reference books on how you can explain the existence of atmospheric pressure using Magdeburg hemisphere.

## 3.2 Factors influencing atmospheric pressure

### Activity 3.4 To find out factors that influence atmospheric pressure

#### Materials

- Internet enabled computers
- Reference books

#### Step

1. Suggest the factors that influence atmospheric pressure.
2. Explain to your classmates how the factors you have suggested in step 1 influence atmospheric pressure.
3. Now conduct a research from the internet or reference books on factors that influence atmospheric pressure. Write them down.
4. In your research, find out why athletes prefer training at high altitudes.
5. Give a summarised presentation on your findings to the whole class through your secretary.

#### (a) Altitude

The main factor that affects atmospheric pressure at a given location is the altitude (or height above sea level) of the location. The maximum air density is at the earth's surface. The air density decreases with the height away from the surface of the earth (See Fig. 3.5).

This is because the pull of the earth's gravity on the air is less.

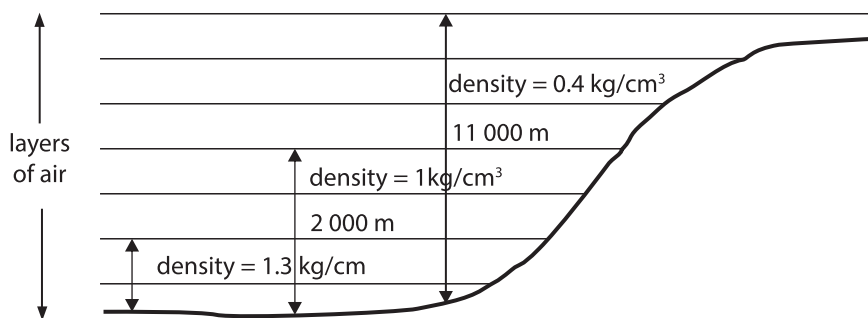


Fig. 3.5: Atmospheric pressure varies with altitude

The fewer number of gas molecule at higher altitude means fewer molecular collisions and a decrease in atmospheric pressure.

The following are some of the effects of increasing altitude on the human body.

1. At high altitude (about 1500 m and above), there is still approximately

21% of oxygen in the air, but since the atmospheric pressure at this level is low, the pressure exerted by oxygen is reduced. Due to pressure gradient, more energy is required by the lungs to take in oxygen. Hence, to adapt to the difficulty of obtaining oxygen, the body will increase the production of red blood cells and hemoglobin in the blood, as well as reduce muscles metabolism to enable a more efficient use of oxygen. This effect lasts for upto two weeks after returning to the lower altitude giving athletes who is training at high altitude a competitive advantage.

2. When altitude increases, the atmospheric pressure drops, tissue in the human body expand. The expansion of tissues in and surrounding the joints aggravates nerves causing pain.
3. A drop in atmospheric pressure such as in an ascending airplane also causes headaches, particularly sinus headache. This is because gases in the sinuses and ears are at higher pressure than those of the surrounding air. The pressure tries to equalise, causing pain in the face and ears.
4. Sometimes when we are at high altitude, our noses may start bleeding. There are many reasons for nose bleeding, but bleeding at high altitude is associated with the surrounding weather conditions. As one climbs up the mountain (change in altitude), the atmospheric pressure is reduced, temperature decrease and the water vapour content becomes less. The presence of water vapour in the air acts as a lubricant for the movement of air through the nose. Its reduction increases friction and irritation of nasal membrane resulting to bleeding.

### **(b) Temperature**

When atmospheric air is heated (such as by radiation from the sun), the air molecules become active. The space between the neighbouring air molecules increases and reduces air density. Lowering the air density decrease the amount of pressure exerted by the air i.e. atmospheric pressure. Therefore, given equal volume of air, warm air is less dense than cold air and exert less pressure.

### **(c) Water vapour concentration (humidity)**

When water evaporates into the atmosphere its molecules take the place of gas molecules in the air. The water vapour is less denser than dry air. Hence, wet air being less dense exerts less pressure than dry air. Therefore, atmospheric pressure decreases with increase of humidity (water vapour in the atmosphere).

### (d) Wind Pattern

Atmospheric pressure is also influenced by wind patterns. Winds causes convergence (moving together) and divergence (moving apart) of air at the earth's surface. When the wind converges, air molecule increases exerting more pressure on the surface whereas it exerts less pressure when the wind diverges since air molecules decrease in number.

The combination of these factors make atmospheric pressure an important parameters in predicting weather.

In general, weather becomes stormy when atmospheric pressure falls due to air becoming warmer or humid. The convergence of air masses at the surface of the earth causing convection and rising of air. It becomes fair when atmospheric pressure rises due to drier, colder air and the divergence of air masses. Therefore, if a weather person on television says that the barometer is falling, you might want to get your raincoat out!

### Exercise 3.2

1. List four factors that influences atmospheric pressure.
2. Explain why it is difficult to cook food while on top of a mountain.
3. Briefly explain why athletes in Rwanda normally enter residential training camp in Musanze District for training and not Rusizi District near Rusizi river.
4. Discuss how the temperature and wind patterns affects atmospheric pressure.
5. A student in senior three started nose bleeding while they were in a trip at the top of Mt. Karisimbi.
  - (a) Explain the possible reason for her nose bleeding
  - (b) Discuss how you can help her to stop nose bleeding.

## 3.3 Instruments for measuring atmospheric pressure

### Activity 3.5

To measure atmospheric pressure using mercury barometer

#### Material:

- Mercury barometer

#### Caution

Mercury barometer is heavy, fragile and explosive. Care must be taken when handling it.

## Steps

1. Take the mercury barometer provided and observe its calibrations. What is the height of the column of mercury in it? Record it down.
2. Tell your classmate why mercury is used as a barometric liquid and not water.
3. Predict what will happen to the level of the mercury as you climb up a high. Explain.
4. Discuss with your group members other instruments used to measure atmospheric pressure apart from the mercury barometer.
5. Give a summarised report on your findings to the whole class in a class discussion.

### (a) Mercury Barometer

A mercury barometer consists of a thick-walled glass tube, which is closed at one end. The tube is completely filled with mercury and inverted repeatedly to remove air bubbles. The tube is then completely filled again with mercury and inverted into a trough containing mercury.

The mercury column drops until it reaches a height of 76 cm above the lower level of the mercury meniscus (see Fig. 3.6) if the barometer is at sea level.

When the barometer is placed in a region with lower atmospheric pressure e.g. high on the mountain, the height of the mercury column in the tube drops to a level showing the atmospheric pressure at that place..

This barometer can be used in the laboratory or weather station, but it is not easy to move it from one place to another.

### (b) Fortin Barometer

The simple mercury barometer discussed above cannot be used for accurate measurement of atmospheric pressure. An improved version called the **Fortin barometer** is used where high level of accuracy is required. Fig. 3.7 shows a Fortin barometer.

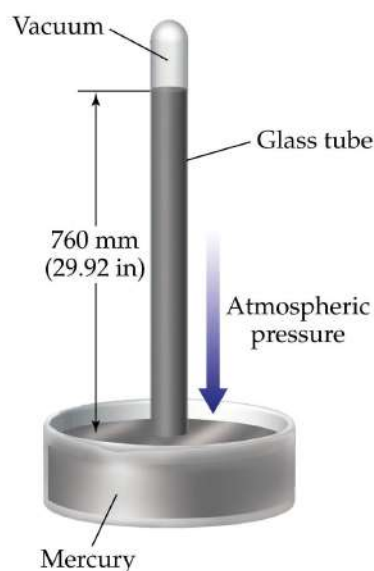
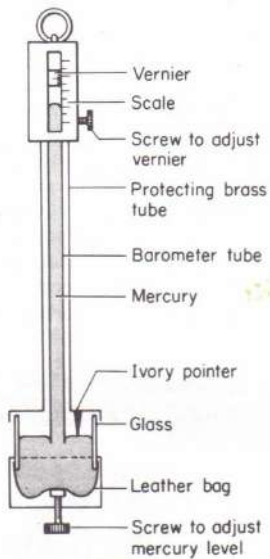


Fig. 3.6: Mercury barometer



(a) Drawing of Fortin barometer



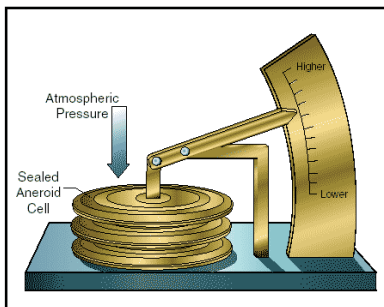
(b) Photograph of Fortin barometer

Fig. 3.7: Fortin Barometer

Before taking the reading, the level of mercury surface in the reservoir is adjusted by turning the adjusting screw until the surface of the mercury just touches the tip of the ivory pointer. The mirror-like mercury surface produces an image of the tip which helps to make the adjustment very accurate. The height of mercury is then read from the main scale and the vernier scale. Any change in air pressure makes the surface to move up and down hence this adjustment is necessary before the barometer is read.

### (c) Aneroid Barometer

The aneroid barometer is another example of a portable barometer. It consists of a sealed metal chamber in the form of a flat cylinder with flexible walls. The chamber is partially evacuated and the spring helps in preventing it from collapsing. Fig. 3.8 shows an aneroid barometer.



(a) drawing of aneroid barometer



(b) Photograph of aneroid barometer

Fig. 3.8: Aneroid Barometer

The chamber expands and contracts in response to changes in atmospheric pressure. The movement of the chamber walls is transmitted by a mechanical lever system which moves a pointer over a calibrated scale.

Normally, the pointer indicates a particular value of atmospheric pressure of the surrounding. Any changes in pressure is noticeable by the movement of the pointer to either side of this atmospheric value on the scale.

The aneroid barometer has no liquid and is widely used as an altimeter by mountaineers or pilots to determine altitude. The scale can be calibrated to give readings of altitude equivalent to a range of values of atmospheric pressure.

An aneroid barometer is also used as a weather glass to forecast the weather. Rainy clouds form in areas of low pressure air. This is shown by the fall in the barometer reading which often means that bad weather is coming.

### Exercise 3.3

1. Name a liquid that is used for constructing instruments that measures atmospheric pressure. Give a reason why the liquid is preferred over others.
2. Describe how you can measure atmospheric pressure at the top of a mountain.
3. Describe the working of:
  - (a) Mercury barometer.
  - (b) Aneroid barometer.
4. Explain how you can test for the vacuum in a barometer.
5. The atmospheric pressure in a particular day in Kigali was measured as 740 mmHg. Express this  $\text{Nm}^{-2}$ . (Assume density of mercury is  $13600 \text{ kgm}^{-3}$  and  $g = 10 \text{ N/kg}$ )
6. A senior three student plans to make a barometer using sea-water of density  $1025 \text{ kgm}^{-3}$ . If the atmospheric pressure is  $104\,000 \text{ Nm}^{-2}$ , what is the minimum length of the tube that the student will require?

## 3.4 Applications of atmospheric pressure

### Activity 3.6

To demonstrate some applications of atmospheric pressure

#### Materials

- Drinking straw
- Glass
- Drinking water
- Rubber sucker
- Empty beakers
- Syringe



### Steps

1. Take a drinking straw provided to you and dip it in the glass with clean drinking water.
2. Sip the water using the straw. What do you observe? Explain.
3. Dip the nozzle syringe in the water. What do you observe? Explain your observation.
4. Take two empty beakers and fill one with water.
5. Now, discuss with your classmates how a rubber sucker, syringe and lift pump work.
6. Note down the main points from your discussion.
7. Give a summarized report on your findings to the whole class through a discussion.

#### (a) Drinking straw

Sucking through a straw, reduces the air pressure inside the straw. The atmospheric pressure forces the water into your mouth through the straw (Fig 3.9).

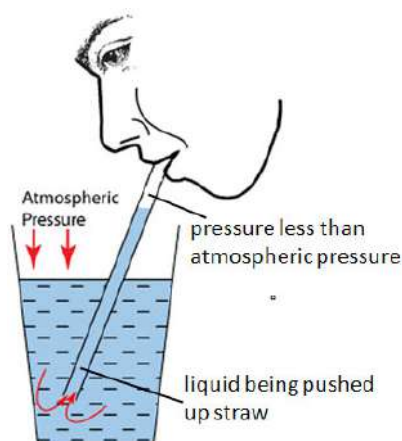


Fig. 3.9: Drinking straw

#### (b) Syringe

A syringe consists of a tight-fitting piston in a barrel (Fig. 3.10(a)). It is used by doctors to give injections.

Consider the case which the piston is not dipped in a liquid. When the piston is pulled with the nozzle open, space is created in the barrel lowering the pressure inside. Air from outside is pushed in by atmospheric pressure. Since the barrel is also open to the outside, both the top and the bottom of the piston are under the same force but in different directions. Hence the piston moves freely. The same



happens when the piston is pushed only, that the pressure increases inside the tube and is balanced by the atmospheric pressure once the air is pushed out of the barrel by the piston.

When the nozzle is closed and the piston is pushed, the pressure inside increases and the movement of the piston is restricted.

Consider the case when the nozzle of the syringe inside a liquid (Fig. 3.10(b)).

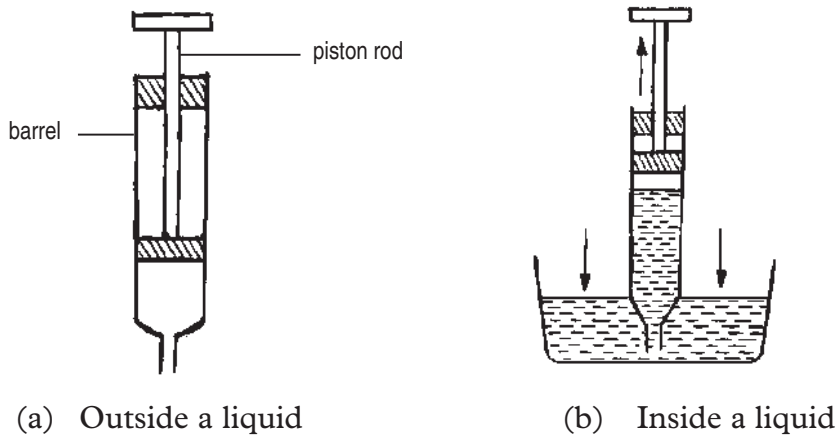


Fig. 3.10: A syringe

When the piston is pulled (upstroke) the pressure inside reduces and the atmospheric pressure on the surface of the liquid pushes the liquid into the barrel. During a downstroke, the pressure inside increases and the liquid is expelled from the barrel.

### (c) Lift pump

A lift pump is used to raise liquids from a low level to a high level e.g raising water from a well, drawing paraffin from a drum etc. The pump consists of a cylindrical metal barrel with a delivery tube (Fig. 3.11). Inside the barrel, there is a piston and two valves. Before starting to operate the pump, some of the liquid to be drawn is poured on top of the piston in order to have a good air tight seal round the piston and valve 2.

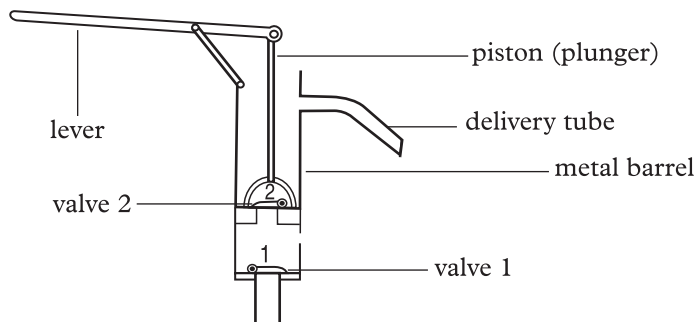


Fig. 3.11: A lift pump

The pump is operated by means of a lever which moves the plunger up and down the barrel.

**(i) Upstroke**

During upstroke, the air between valve 1 and 2 expands and its pressure reduces below atmospheric pressure. The atmospheric pressure on the water surface forces water up past valve 1 into the space between valves 1 and 2. At the same time valve 2 closes due to its weight as shown in Fig. 3.12(a).

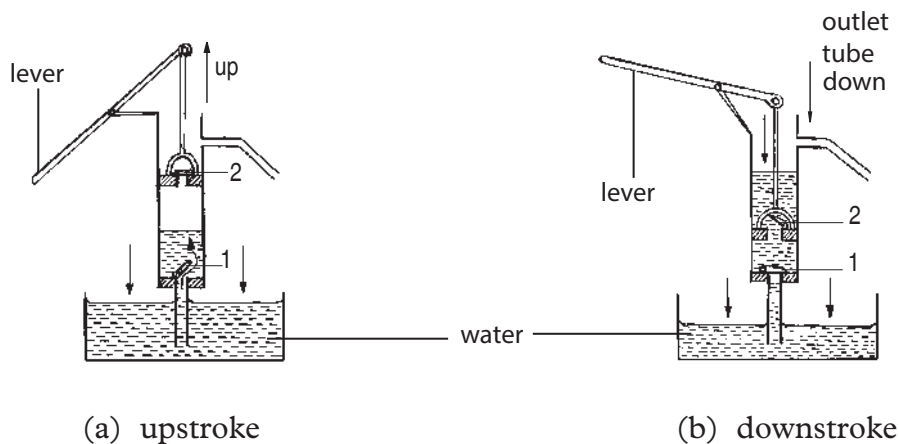


Fig. 3.12: Working of a lift pump

**(ii) Downstroke**

During downstroke, valve 1 closes due to its weight and the weight of the water in the space between valves 1 and 2. As the plunger moves down, it forces valve 2 to open. Water escapes into the space above valve 2. As the process is repeated, the plunger lifts the water out through the delivery tube.

Since atmospheric pressure can only support a water column of about 10 m, this pump cannot raise water above a height of 10 m. The situation becomes even worse when the pump is used in areas well above sea level where atmospheric pressure is low.

**(d) Siphon**

A flexible tube may be used to empty fixed containers e.g. petrol tanks in cars, which are otherwise not easy to empty directly. When used in this manner, the flexible tube is called a *siphon*.

To empty the liquid in the container, the siphon is first filled with the liquid. One end is pushed into the liquid and the other one left hanging as shown in Fig. 3.13. The liquid comes out of the end C.

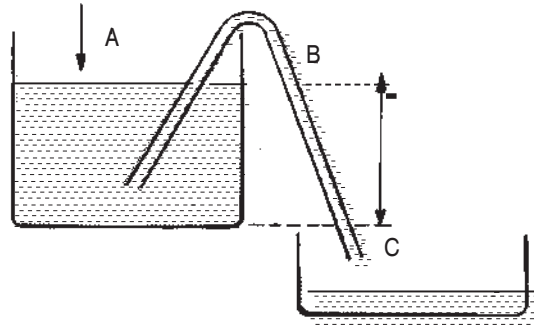


Fig. 3.13 : A siphon

The pressure at B is atmospheric since B is on the same horizontal level as the surface A. The pressure at C in the liquid is greater than the atmospheric pressure by the pressure due to the height BC. This difference in pressure causes the water to flow out of the container.

#### (e) Automatic flushing unit

Fig. 3.14 shows a flushing unit system.

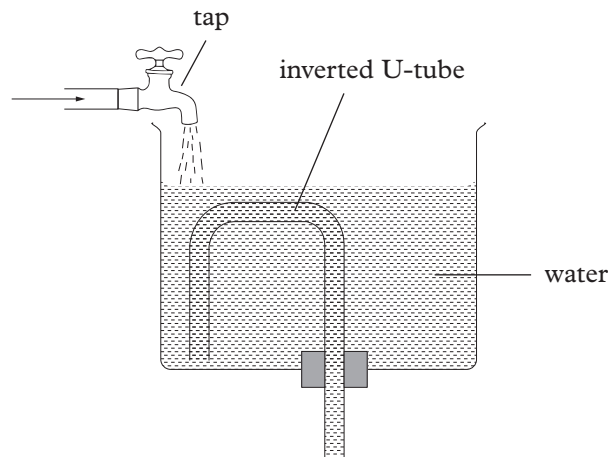


Fig. 3.14: Automatic flushing unit

It is normally used in urinals and flush toilets. When the water in the tank fills above the top of the inverted U-tube, a pressure difference between the two arms is created. This causes the water to flow out of the tank. The tap can be adjusted to enable the flushing unit to flush at pre-determined intervals.

#### (f) Rubber Sucker

A rubber sucker (Fig. 3.15) can be used for lifting heavy objects with flat smooth surface and for hanging things on walls and windows.

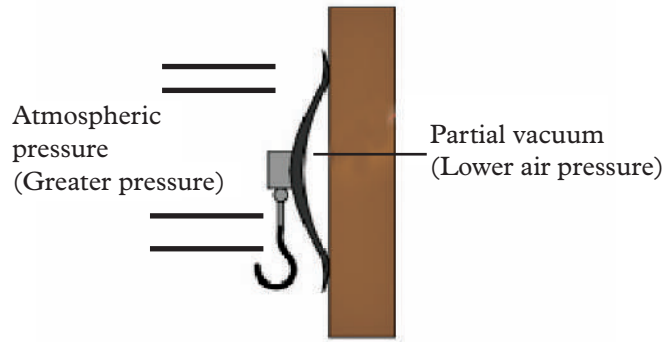


Fig. 3.15: A Rubber Sucker

When a rubber sucker is pressed against the surface, usually a glass or tiled surface, the air in the rubber sucker is forced out. This causes the space between surfaces and sucker to have low pressure (partial vacuum). The external atmospheric pressure, which is much higher acts on the rubber suckers, pressing it securely against the wall.

### (g) Vacuum cleaner

A vacuum cleaner (Fig. 3.16) applies the principle of atmospheric pressure to remove dust particles.

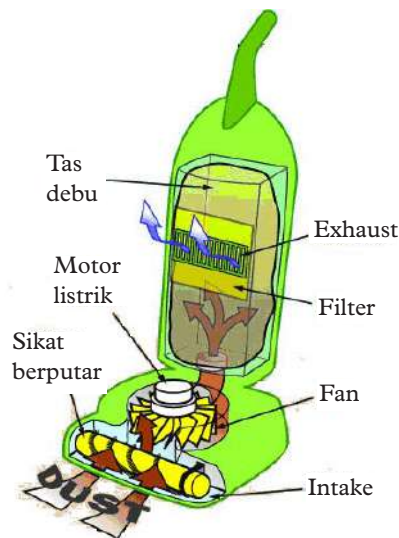


Fig. 3 16: A vacuum Cleaner

When the vacuum cleaner is switched on, the fan sucks out the air from the space inside creating a partial vacuum. The atmospheric pressure outside, which is greater, then forces air and dust particles into the filter bag. This traps the dust particles but allows the air to flow out through an exit at the back.

### Exercise 3.4

1. Explain the action of a drinking straw.
2. Draw and explain the features of a siphon.
3. Explain how a rubber sucker and vacuum cleaner works.
4. Draw and explain the function of a syringe.
5. What is the function of the compressed air in the force pump?

### Unit summary and new words

- Atmospheric pressure is the pressure due to the column of air above the surface of the earth.
- Factors that influence atmospheric pressure include
  - (i) Altitude
  - (ii) Temperature
  - (iii) Water vapour concentration
  - (iv) Wind pattern
- Atmospheric pressure decreases with the increase in altitude.
- Atmospheric pressure decreases with increase in air temperature.
- Atmospheric pressure increases with convergence of winds and decreases with divergence of winds.
- Instruments used to measure atmospheric pressure include:-
  - (i) Mercury barometer
  - (ii) Fortin barometer
  - (iii) Aneroid barometer
- Some of the situation in which atmospheric pressure is applied include:
  - (i) When using a drinking straw
  - (ii) When using a Syringe
  - (iii) When siphoning liquids
  - (iv) When cleaning using a vacuum cleaner
  - (v) When hanging clothes using a rubber sucker on a smooth wall
  - (vi) In an automatic flushing unit

## Unit Test 3

**For questions 1 - 3, select the most appropriate answer.**

1. The following are factors influencing atmospheric pressure. Which one is not?
  - A. Temperature
  - B. Water vapour concentration
  - C. Cloud cover
  - D. Altitude
2. Which one of the following instruments is used for measuring atmospheric pressure?
  - A. Temperature
  - B. Barometer
  - C. Thermometer
  - D. Lactometer
3. Which one of the following statements is correct?
  - A. When altitude increases atmospheric pressure also increases.
  - B. When altitude increases atmospheric pressure remains constant.
  - C. When altitude increases atmospheric pressure also decreases.
  - D. There is no relationship between increase in altitude and atmospheric pressure.
4. Use the words given to fill in the spaces.  
*atmosphere, barometer, atmospheric, density*  
Earth surface is surrounded by a thick layer of air called \_\_\_\_\_. The \_\_\_\_\_ of air varies from the earth's surface to the outer place. The pressure exerted by air is called \_\_\_\_\_ pressure and its measured using an instrument called \_\_\_\_\_.
5. State and briefly explain three factors that influence atmospheric pressure.
6. The Fig. 3.17 shows a rubber sucker. Explain why the sucker sticks on a flat surface.

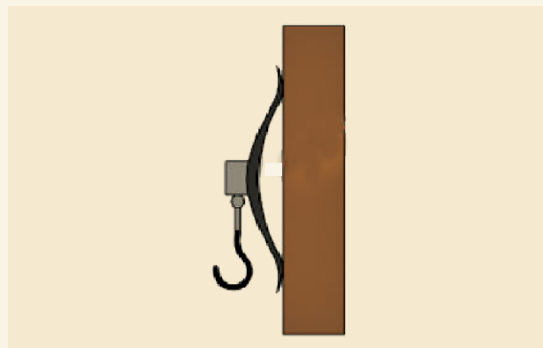


Fig. 3.17: Rubber sucker

7. The air pressure at the base of a mountain is 76.0 cm of mercury while at the top it is 43.0 cm of mercury. Given that the average density of air is  $1.25 \text{ kg m}^{-3}$  and the density of mercury is  $13600 \text{ kg m}^{-3}$ , calculate the height of the mountain.
8. Describe briefly how an automatic flushing unit operates.
9. Explain how you can use mercury barometer to measure atmosphere pressure in your school.
10. Outline and briefly discuss four applications of atmospheric pressure in our daily lives.
11. Explain how altitude affects atmospheric pressure.
12. Hibimana and Hakizimana, Senior three students put hot drinking water in a plastic container and then placed it on the ice in a basin as shown in Fig. 3.18.



Fig. 3.18: Plastic container with hot water on ice

Explain why some of the ice cubes stick onto the bottle.

**Hey! Drink safe water!**

Always drink boiled water to avoid waterborne diseases such as typhoid.

# Renewable and non-renewable energy sources

## Key Unit Competence

By the end of the unit, the learner should be able to differentiate between renewable and non-renewable energy sources and give examples.

## Learning objectives

### Knowledge and understanding

- Outline renewable and non-renewable energy sources.
- Describe basic features of renewable and non-renewable energy sources.

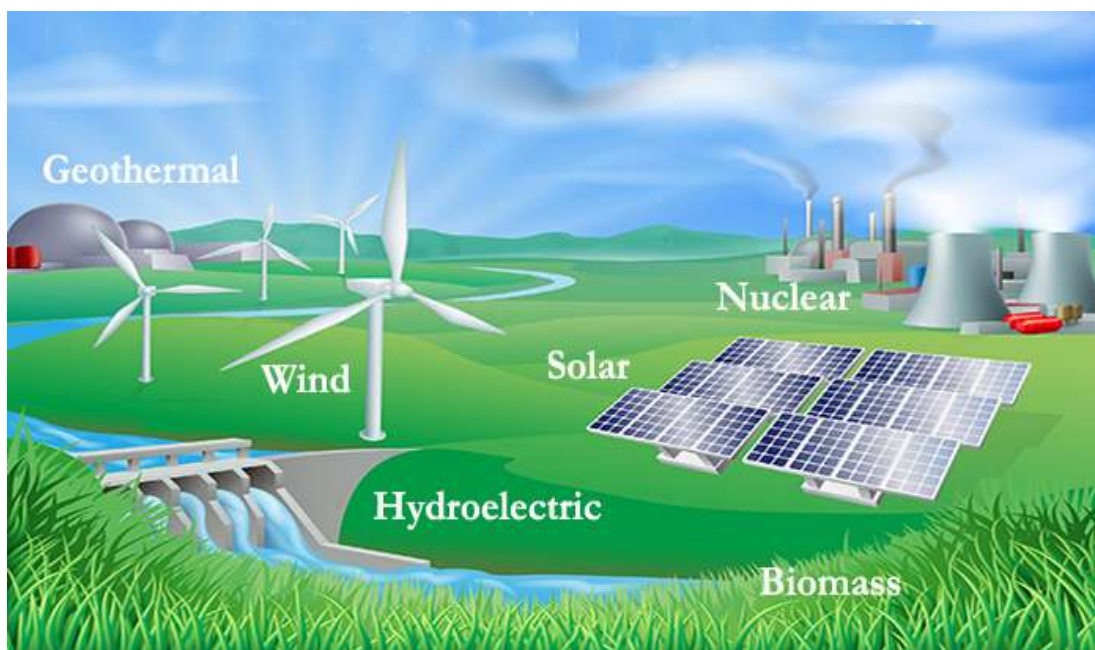
### Skills

- Compare energy sources in Rwanda and the rest of the world.
- Classify energy sources as renewable and non-renewable energy sources.
- Estimate the rate of fuel consumption in power stations.
- Analyse transformation of energy into different forms.

### Attitude and value

- Recognize sources associated with carbon dioxide emission.
- Appreciate that in most instances, the sun is the prime energy source for world energy.
- Appreciate higher rate of energy consumption in developed countries is from large deposits of fossil fuels.
- Be aware of the moral and ethical issues associated with nuclear weapons.
- Adapt scientific method of thinking.
- Recognize the need of acquiring knowledge for analysing and modeling physical processes.





## Introduction

### Unit Focus Activity

1. On a piece of paper provided by your teacher, write down:
  - (a) The meaning of renewable and non-renewable sources of energy
  - (b) At least eight sources of energy.
  - (c) Classify the sources you have listed as either renewable or non-renewable. Organise your classification in a table.
  - (d) Three ways of conserving non-renewable sources of energy.
  - (e) Describe the energy transformations in
    - (i) a swinging pendulum
    - (ii) a loud speaker
2. Present your work to the rest of the class during the class discussion.

Energy is useful in our daily lives. We need energy for any kind of work we do. Energy comes from different sources. Some are renewable while others are non-renewable.

In this unit, we are going to learn in details about these sources of energy.

## 4.1 Energy sources

### Activity 4.1

To identify and define energy sources

#### Material

- A chart showing pictures of different sources of energy

#### Steps

1. Look at the pictures in Fig. 4.1.

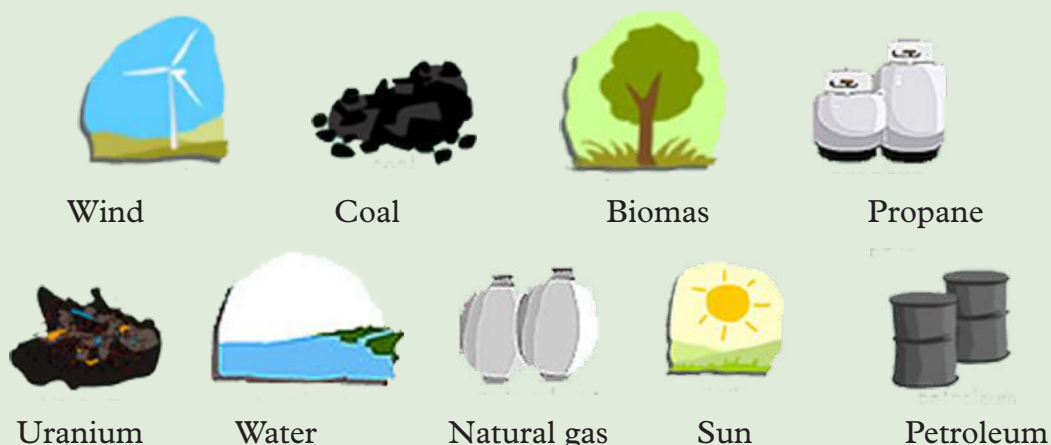


Fig 4.1:

2. What name collectively describes the objects in the pictures?
3. Discuss with your classmates the meaning of the terms 'source' and 'energy source'.
4. With the help of your teacher, compile your findings and note them in your books.

The word 'source' means the beginning of something. An energy source is a system which produces energy in a certain way. Examples of energy sources are energy from water, wind, the sun, geothermal sources, biomass sources such as energy crops, fuels such as coal, oil, and natural gas. These sources show that energy exists freely in nature.

## 4.2. Classification and characteristics of energy sources

### Activity 4.2

To classify energy sources

#### Steps

1. Distinguish between renewable and non-renewable sources.
2. Revisit activity 4.1 and categorize the energy sources shown in the picture as either renewable or non-renewable sources.

Energy sources are classified as renewable or non-renewable sources.

### 4.2.1 Renewable sources

#### Activity 4.3

#### To find out what renewable resources are

##### Steps

1. Discuss with your classmate the meaning of renewable sources of energy.
2. Identify at least three (3) characteristics of renewable sources of energy.
3. Describe three examples of renewable sources of energy in Rwanda and the World.

Renewable energy sources are energy sources that are continually replenished. They exist infinitely (they never run out).

#### 4.2.1.1 Characteristics of renewable resources

- These resources are capable of regeneration.
- They are renewed along with exploitation and hence are always available for use.
- The regeneration of these sources involves some ecological processes on a time scale.
- The renewable sources become non-renewable if used at a greater rate than the environment's capacity to replenish them.

#### 4.2.1.2 Examples of renewable sources of energy

Renewable energy includes biomass, wind, hydro-power, geothermal and solar sources. Renewable energy can be converted to electricity, which is stored and transported to our homes and industries for use.

#### (a) Wind energy

#### Activity 4.4

#### To conduct a research on wind energy

##### Materials:

- Reference books
- Internet

##### Steps

1. Why is wind energy regarded as a renewable source of energy?
2. Outline advantages and disadvantages of using wind energy.

3. Compare and discuss your findings with other groups in your class.
4. With the help of the teacher, note down your findings in your note books.

The term "wind energy" or "wind power" refers to the energy produced by wind. It is used to rotate turbines that convert kinetic energy into other forms that can be used to do specific tasks such as grinding grain, pumping water or generate electricity to power homes, businesses, schools, and industries.

Wind is produced as a result of giant convection currents in the Earth's atmosphere which are driven by heat energy from the sun. This means that the kinetic energy in wind is a renewable energy resource; as long as the sun exists, the winds will always be.

Figure 4.2 shows a wind turbine.

Wind turbines have huge blades mounted on a tall tower. The blades are connected to nacelle or housing that contain gears linked to a generator. As the wind blows, it transfers some of its kinetic energy to the blades which turn and drive the generator. Several wind turbines may be grouped together in windy locations to form *wind farms*.

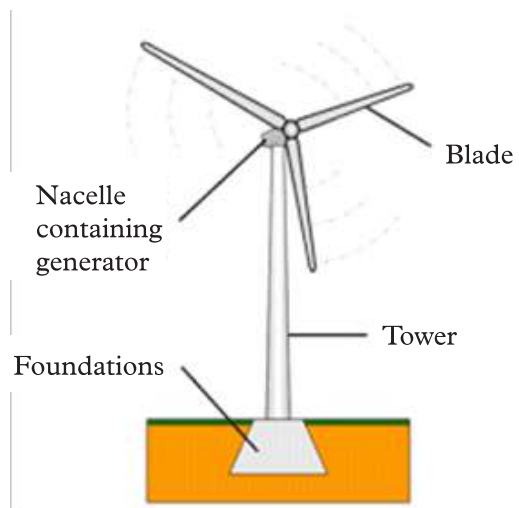


Figure 4.2: A wind turbine

As at the writing of this book, the Rwanda government had put a number of initiatives on exploring ways of implementing wind power generation at suitable locations in the country. However, small scale exploitation of wind power like mills for pumping water or generating homestead electricity is in common use in some regions of Rwanda.

#### **Advantages of wind energy**

- Exploitation and utilisation of wind energy has no associated fuel costs.
- No harmful polluting gases are produced by wind energy.

#### **Disadvantages of wind energy**

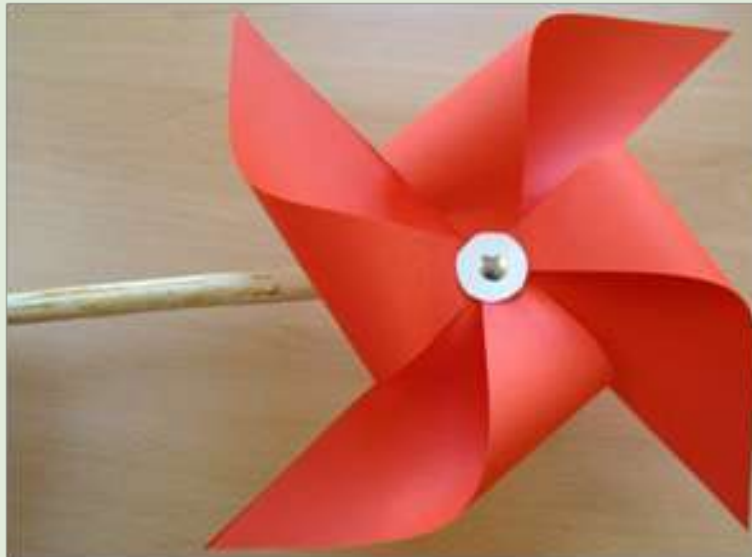
- Wind farms are noisy and may cause noise pollution for people living near them.
- The amount of electricity generated depends on the strength of the wind. If there is no wind, there is no electricity.

**Project 4.1.****To make a simple wind turbine****Materials**

- Manilla paper
- A pair of scissors
- Pencil
- A nail
- Stapler

**Steps**

1. Cut a square piece from the manilla paper.
2. Use a ruler to draw diagonal lines from corner to corner. Make a small mark along each diagonal line about 2 cm from the center of the square piece.
3. Cut along the diagonal lines toward the center until you reach the 2 cm mark.
4. Fold alternating corners onto the center and staple the layers together, but make sure to leave space between staples in the very center.
5. When all four 'blades' are folded in, push a straight nail through all the layers at the center. Remove the nail and push the pencil through the hole to act as the 'shaft'. The turbine is now complete (Fig 4.3). Make sure the turbine is free to rotate on the pencil



*Fig. 4.3: A simple wind turbine*

6. Hold the turbine in the direction of the wind. The wind currents blow the curved part of the blades, causing them to spin.

## (b) Water energy

### Activity 4.5

#### To research on the exploitation, advantages and disadvantages of water energy

##### Materials:

- Reference books
- Internet enabled computers

##### Steps

1. Conduct a research from reference books or the internet on how electricity is generated using waves, tides and flowing water (HEP).
2. Discuss the disadvantages associated with each one of them.
3. Compare and discuss your findings with the rest of your classmates.
4. With the help of your teacher, note down your findings in your notebooks.

Moving water mainly produces energy in the form of wave power, tidal barrage, and hydroelectric power.

#### Wave energy

The water in the sea rises and falls because of waves on the surface. Wave machines use the kinetic energy in this movement to drive electricity generators.

#### Tidal barrage

Huge amounts of water move in and out of river mouths each day because of the tides. A tidal barrage is a barrier built over a river estuary to make use of the kinetic energy in the moving water. The barrage contains electricity generators, which are driven by the water rushing through tubes in the barrage.

#### Hydroelectric power (HEP)

Hydroelectric power stations use the kinetic energy in moving water. The water comes from vast reservoirs behind a dam built across a river valley. The water high up in the dam possesses gravitational potential energy. This is transformed to kinetic energy as the water rushes down through tubes inside the dam. The moving water drives electrical generators which are built at the base of the dam.

Examples of HEP stations in Rwanda include Nyabarongo Power Station with a capacity of 28 megawatts, located in Mushishiro, Muhanga District and Rukarara II, which has a capacity of 2.2 megawatts in Nyamagabe district.



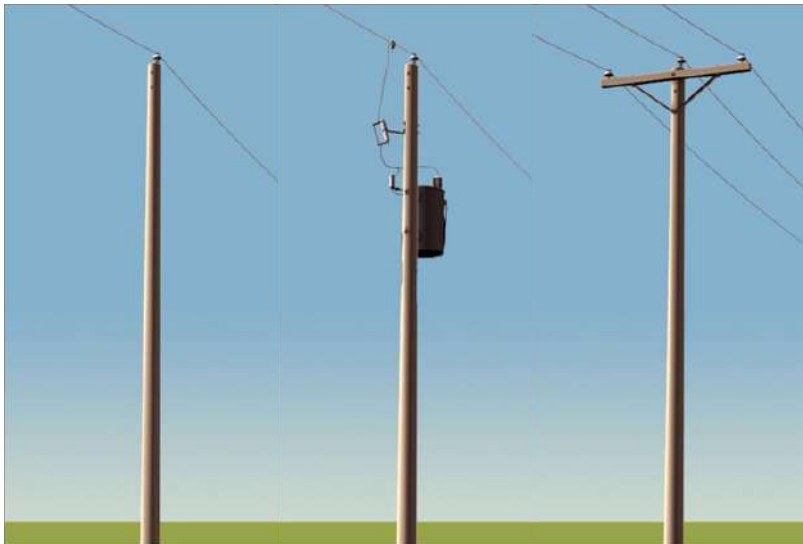
Fig 4.4 Shows Nyabarongo dam.



*Fig. 4.4: Nyabarongo dam in Mushishiro in Muhanga district*

Hydro dams can generate large amounts of electricity. However, dry periods can drain the reservoirs resulting to less power production. The flooding of reservoirs behind dams and slowing of the flow of the river below the dam can have a serious impact on the ecology around the dam. The number of sites suitable for new dams is limited.

Fig 4.5 and 4.6 shows distribution and transmission lines in Rwanda respectively.



*Fig 4.5 An electricity distribution line*



Fig. 4.6: Higher capacity transmission lines being set up

### For your safety

1. Never let yourself or anything else (a tool, scaffolding, construction materials or a tree branch) come within three metres of a medium-voltage wire when pruning or felling a tree.
2. These high-voltage lines are not insulated hence nothing should come near them. Carrying out work near these lines or planting anything in the right-of-way without proper authorization is prohibited.
3. Don't climb fences near hydropower facilities. They are there for your safety!

### Advantages of water energy

- Water power in its various forms is a renewable energy resource and has no associated fuel costs.
- No harmful polluting gases are produced.
- Tidal barrages and hydroelectric power stations are very reliable and can be turned on quickly.

### Disadvantages of water energy

- It has been difficult to scale up the designs for wave machines to produce large amounts of electricity.
- Tidal barrages destroy the habitat of estuary species, including wading birds.
- Hydroelectricity dams may flood farmlands and push people away from their homes.
- The rotting vegetation underwater releases methane, which is a greenhouse gas that contributes to global warming and ozone layer depletion.



**(c) Solar energy****Activity 4.6****To demonstrate solar energy using a convex lens****Materials:**

- Convex lens
- Thin piece of paper

**Steps**

1. Choose a clear bright day with a lot of sunshine.
2. Place a convex lens in the path of sunlight.
3. Place a thin piece of paper under the lens. Ensure that light is focused on the paper.
4. Wait for some minutes. What happens to the paper? Explain.

"Solar" is a Latin word for "sun". Solar power is energy from the sun. It is a powerful source of energy. Without it, there would be no life. It has been considered Earth's main source of energy for many years because of the vast amounts of energy that it makes freely available, if harnessed by modern technology.

Unfortunately, the sun is not available in the night, and on some days, clouds and rains and other natural conditions prevent the sun's powerful rays from reaching us. This means that it is not always available. This is why we cannot rely on solar energy alone.

An example of a solar power station in Rwanda is Ngoma solar power station located in Agahozo village (ASYU) in Rubuna Sector, Rwamagana District; which produces 8.5 megawatts. The largest solar power station in the world as at the time of writing this book is Cestas Solar Plant in France whose capacity is 300 megawatts.

*Transducers* that tap solar energy and convert it to other forms of energy include solar cells (photovoltaic cells) and solar thermal heaters.

**Solar cells( Solar panels)**

Solar cells also called **photovoltaic cells** or **PV devices** are devices that convert light energy directly into electrical energy. In these cells, there are semiconductors (silicon alloys and other materials). You may have seen small solar cells on calculators or some mobile phones. Larger arrays of solar cells are used to power road signs in remote areas, and even larger arrays are used to power satellites in orbit around Earth.



(a) Placing solar panel on the roof top



(b) Cleaning solar panel

Fig. 4.7: Solar panel

## Solar thermal heaters

### Project work 4.2

### To make a solar balloon

#### Materials:

- A small trash bag
- 13  $\mu\text{m}$  thick black bag
- Scissors
- A sewing thread
- Bottle cap

#### Steps

1. Choose your day: clear sky, little or no wind, early in the morning before thermal activity.
2. Get the trash bag and tie its neck with a sewing thread.
3. Cut other four pieces of the sewing thread and tie them on the neck of the trash bag around it and use them to attach a small weight like a plastic bottle cap.
4. Inflate the flash bag (Fig. 4.8)
5. Lay the trash bag on the ground clearly exposed to the sun.
6. Observe and explain what will happen when the bag is gradually heated by the sun.



Fig 4.8: A simple solar balloon.

*Solar hot water systems (also known as Solar thermal)* harness heat from the sun by capturing energy which is radiated by the sun within solar panels or collectors.

Solar thermal heaters should not be confused with Solar Photovoltaic (PV), devices which are designed to generate electricity.

The heat energy is then moved down pipes to the hot water cylinder within your home, reducing the need to use gas, oil or electricity to heat the required water.

A pump pushes cold water from a storage tank through pipes in the solar panel. The water is heated by heat energy from the sun and returns to the tank. In some systems, a conventional boiler may be used to increase the temperature of the water. They are often located on the roofs of buildings where they can receive the most sunlight.

Fig 4.9 shows the outline of how they work.

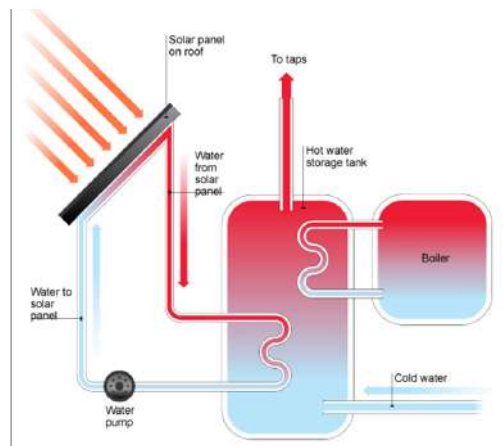


Figure 4.9 showing a solar thermal heater

*Solar thermal power plant.* Here, a concentration of the sun's energy by many panels is used to heat up water into steam, which is then used to turn turbines to produce electricity.

### Guess what!

Solar power stations usually require a lot of space to capture a lot of the sun's energy!

The parabolic trough system uses this kind of system. Here, troughs are designed to direct the sun's energy to absorber tubes as long as the sun is up.

Many of these parabolic troughs are installed to collect massive amounts of energy for the rods to heat water to turn turbines.

#### Advantages of solar energy

- Solar energy is a renewable energy resource and it has no associated fuel costs.
- No harmful polluting gases are produced.

#### Disadvantages of solar energy

- Solar cells are expensive and inefficient, so the cost of their electricity is high.
- Solar panels may only produce very hot water in very sunny areas, and in cooler areas may need to be supplemented with conventional boilers.
- Although warm water can be produced even on cloudy days, neither solar cells nor solar panels work at night.

### Did you know?

In many African villages, people use the sun's energy to dry foodstuff like fish, corn and cocoa for storage? That is raw solar energy in use. They spread the foods on large mats and trays in the hot sun for days until the required moisture content is attained. This is commonly practised in regions with a lot of sun.

#### Geothermal energy

Geothermal energy come in the form of hot steam from underground. It is clean and sustainable. Resources of geothermal energy range from the shallow ground to hot water and hot rock found a few miles beneath the Earth's surface, and down even deeper to the extremely high temperatures of molten rock called magma. The steam is used to generate electricity.

Rwanda has been active in exploring its prospective geothermal potential which is manifested in form of hot springs in North-West region (Rubavu, Kalisimbi and Kinigi) and volcanoes in the South-West region (Bugarama). As at the time of writing this book, the exploration at Bugarama was at a reconnaissance stage and was to be followed by geo-scientific survey to estimate the potential of the area.

**Exercise 4.1**

1. What is renewable energy?
2. Why is renewable energy preferable?
3. Name:
  - (a) two renewable sources of energy.
  - (b) which component of sun's energy is responsible for drying clothes?
  - (c) two forms of energy usually used at homes.
  - (d) the radiation emitted from a hot source.
  - (e) two activities in our daily life in which solar energy is used.
  - (f) the kind of surface that absorbs maximum heat.
  - (g) the device that directly converts solar energy into electrical energy.
  - (h) the two elements which are used to fabricate solar cells.
4. What is the main cause of blowing of the wind.
5. State four characteristics of renewable sources of energy.
6. What are some ways that humans used renewable resources of energy centuries or even a millennia ago?
7. Research what kind(s) of renewable energy our country produces. Why is our country an optimal location for that form of renewable energy?
8. Choose a renewable energy resource. Brainstorm on five types of careers in that field.

**4.2.2 Non-renewable sources of energy****Activity 4.7**

**To find what non-renewable resources are and their characteristics**

1. Discuss with your classmates the meaning of non-renewable sources of energy.
2. Identify three (3) characteristics of non-renewable sources of energy.
3. Describe three examples of non-renewable sources of energy in Rwanda.
4. Note down your findings in your note books.
6. Discuss your findings as a whole class with the help of the teacher and note them down in your notebooks.

Non-renewable energy comes from sources that will run out or will not be replenished in our lifetimes or even in many, many lifetimes.

#### 4.2.2.1 Characteristics of non-renewable resources

- These sources are available only in finite quantities and hence are termed as “stock resources”
- They cannot be regenerated easily.
- They are concentrated as minerals usually in the lithosphere of the earth in a number of forms.
- They may be solids (coal, lignite, and minerals), liquids (petroleum) or gases (natural gases).



**Note:** Most non-renewable energy come from fossil fuels. There is also uranium, which is not a fossil fuel.

#### 4.2.2.2 Examples of non-renewable sources of energy

Examples of non-renewable sources of energy include fossil fuels (coal, petroleum, and natural gas) and nuclear energy.

##### (a) Fossil fuels

#### Activity 4.8

To find out the extent to which fossil fuels are used, their advantages and disadvantages

##### Steps

1. Collect data on how many of you in your class use kerosene, gas or none of these for cooking in your homes.
2. In a class discussion, identify advantages and disadvantages of using fossil fuels as a source of energy.
3. Discuss how the use of fossil fuels contributes to global warming.
4. Compile your findings with your teacher and write down the notes in your note books.

Fossil fuels are mainly made up of **carbon**. It is believed that fossil fuels were formed over 300 million years ago when the earth was a lot different in its landscape. It had swampy forests and very shallow seas. This time is referred to as 'Carboniferous Period'.

The fossil fuels are **coal**, **oil** and **natural gas**. They are fuels because they release heat energy when they are burned. They have chemical energy stored within them.

Fossil fuels are usually found in one location as their formation is from a similar process. Let us take a look at the diagram in Fig 4.10 and see how fossil fuels are formed under the sea.

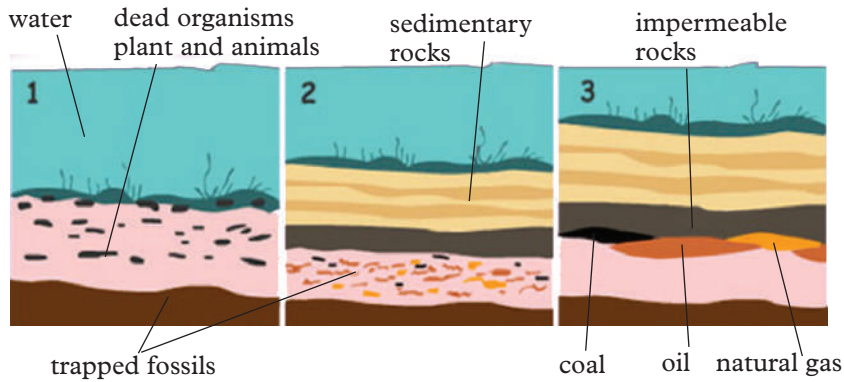


Figure 4.10: Formation of fossils fuels

Millions of years ago, dead sea organisms, plants and animals settled on the ocean floor and in the porous rocks. This organic matter had stored energy in them as they had used the solar energy to make foods through photosynthesis.

With time, sand, sediments and impermeable rock settled on the organic matter, trapping energy within the porous rocks. That formed pockets of coal, oil and natural gas.

Movements in the earth and rock create spaces that force these energy types to collect in to well-defined areas. Using technology, engineers are able to drill down into the seabed to tap the stored energy, commonly known as **crude oil**.

Fig 4.11 shows an energy transfer diagram for using generation of electricity from a fossil fuel like coal.

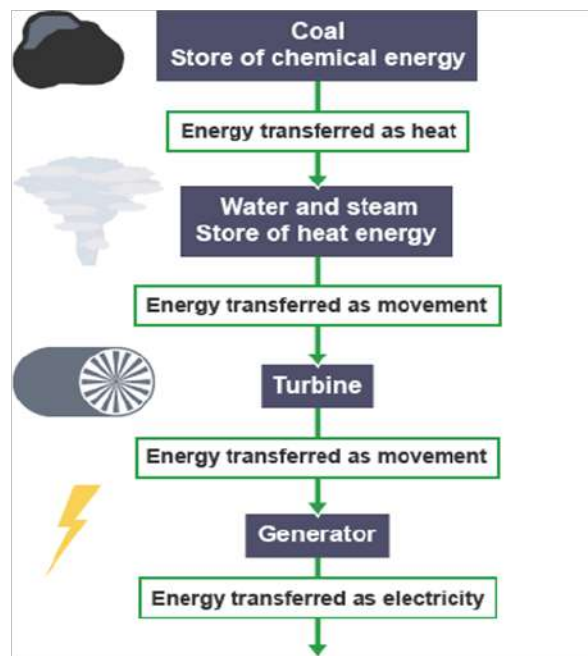


Figure 4.11: Energy transformation diagram



### Advantages of using fossil fuels

Fossil fuels are relatively cheap and easy to obtain. This is the reason why most people prefer using gas or kerosene for cooking over electricity.

Fig. 4.12 shows a (a) cooking gas cylinder and (b) a kerosene stove and kerosene lamp.



Figure 4.12 (a). Gas cylinders at a petrol station in Kigali Rwanda



Figure 4.12(b). Kerosene stove and lamp

### Disadvantages of using fossil fuels

- Fossil fuels are non-renewable energy resources. Their supply is limited and they will eventually run out.
- Fossil fuels release carbon dioxide when they burn, which adds to the greenhouse effect and increases global warming. Of the three fossil fuels, for a given amount of energy released, coal produces the most carbon dioxide and natural gas produces the least.
- Coal and oil release sulphur dioxide gas when they burn, which causes breathing problems for living creatures and contributes to acid rain.



In Rwanda, fossil fuels are widely used in many ways including kerosene and gas for cooking. Diesel and petrol are used for powering locomotives, generators and electricity generation. Substantial amounts of cooking gas (methane) is mined from Lake Kivu, where an estimated of 120 to 250 million cubic metres of methane is generated annually.

This resource can develop methane to power projects and other uses such as fertilizer and gas-to liquids projects.

The methane in Lake Kivu is estimated to be sufficient to generate 700 MW of electricity over a period of 55 years.

### Exercise 4.2

1. Use the words provided below to fill in the blank spaces.

Impermeable, photosynthesis, energy, plants, matter, stored energy, sea bed, movements, shifts, well defined, technology, dead sea organisms, sun's energy, animals.

Millions of years ago, \_\_\_\_\_, \_\_\_\_\_ and \_\_\_\_\_ settled on the ocean floor and in the porous rocks. This organic matter had stored \_\_\_\_\_ in them as they used the \_\_\_\_\_ to prepare foods (proteins) for themselves (\_\_\_\_\_). With time, sand, sediments and \_\_\_\_\_ rock settled on the organic \_\_\_\_\_, trapping its' energy within the porous rocks. That formed pockets of coal, oil and natural gas. Earth \_\_\_\_\_ and rock \_\_\_\_\_ create spaces that force to collect these energy types into \_\_\_\_\_ areas. With the help of \_\_\_\_\_, engineers are able to drill down into the \_\_\_\_\_ to tap the \_\_\_\_\_, which is commonly known as crude oil.

**For questions 2 - 7, select the most suitable response from the options given.**

2. How are fossil fuels formed?
- A. They are made by dead organisms buried in the ground and decomposed.
  - B. They are made by acid rain.
  - C. They are made by bread mold.
3. Fossil fuels are
- A. Renewable
  - B. Non-renewable
  - C. sustainable
4. What are the three main types of fossil fuels?
- A. Coal, natural gas and oil
  - B. Oil, solar and coal
  - C. Solar, coal and natural gas

5. How do we use coal as an energy source?
  - A. Coal is not used as an energy source to generate electricity
  - B. The coal is melted to turn turbines that generate electricity
  - C. The coal is burned to produce steam to turn turbines that generate electricity
6. What is the main element in fossil fuels
  - A. Oxygen
  - B. Water
  - C. Carbon dioxide
7. Why does the world continue to use fossil fuels?
  - A. Because they will never run out and we can continue to use them forever.
  - B. Because they are easily available and are cheap.
  - C. Because they are the only source of energy available for our use.

8. Match

1. Petroleum
2. Wind
3. Biomass.
4. Uranium
5. Propane
6. Solar
7. Geothermal
8. Hydropower
9. Coal
10. Natural Gas

Black rock burned to make electricity.
Energy from heat inside the Earth
Energy from flowing water.
Energy from wood, waste, and garbage.
Energy from moving air.
Produces energy by splitting of atoms.
Portable fossil fuel gas often used in grills.
Fossil fuel for cars, trucks, and jets.
Fossil fuel gas moved by pipeline.
Energy in rays from the sun.

9. Describe the formation of fossil fuels.
10. Explain why fossil fuels are called non-renewable sources.
11. How does the use of fossil fuels affect the environment?

**(b) Nuclear energy**

The main nuclear fuels are uranium and plutonium. These are radioactive metals. Nuclear fuels are not burnt to release energy. Instead, the fuels are involved in nuclear reactions in the nuclear reactor, which released heat. The rest of the process of generating electricity is then identical to the process of using fossil fuels.

The heat energy is used to boil water. The kinetic energy in the expanding steam spins turbines, which then drive generators to produce electricity.

Fig 4.13 shows the structure of a nuclear reactor.

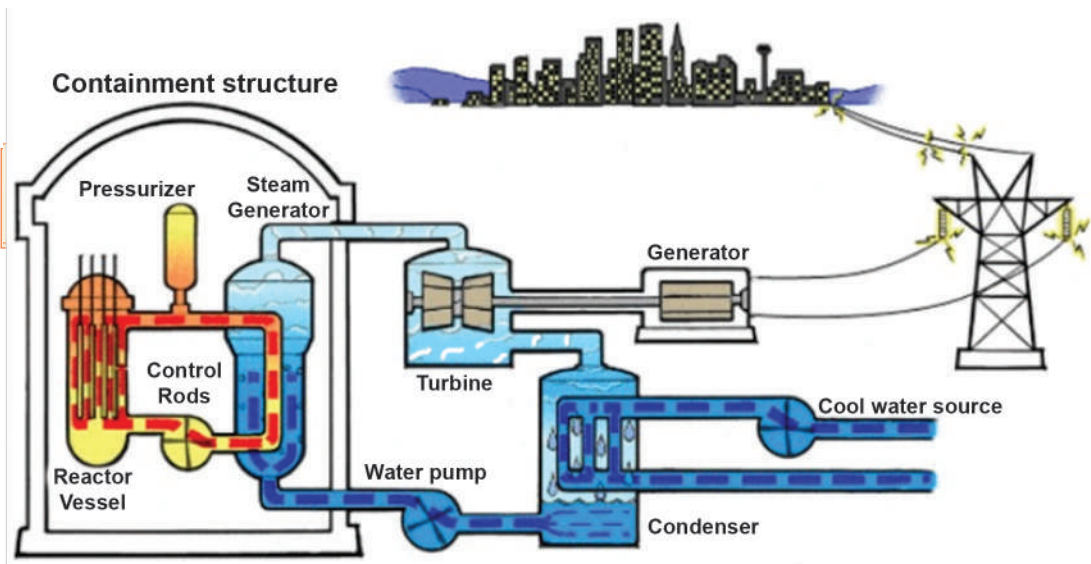


Fig. 4.13: A nuclear power plant

### Advantages of nuclear fuels

- Unlike fossil fuels, nuclear fuels do not produce carbon dioxide or sulphur dioxide.

### Disadvantages of nuclear fuels

- Like fossil fuels, nuclear fuels are non-renewable energy resources hence are depleted with time.
- If there is an accident, large amounts of radioactive material could be released into the environment which would be dangerous to human beings, animals and plants.
- In addition, nuclear waste remains radioactive and is hazardous to health for thousands of years. It must be stored safely.

**For your safety!**

Make sure you wear protective clothing when you visit sites with radioactive substances.

**Exercise 4.3**

**For questions 1 - 6, select the most suitable response from the choices given.**

- Which of the following is used to generate nuclear power?
  - Uranium
  - Hydrogen
  - Carbon
  - None of the above
- How does nuclear fission occur?
  - Protons gather in the nucleus of uranium atoms and cause the nucleus to explode and release energy in the form of heat.
  - Neutrons smash into the nucleus of uranium atoms. The neutrons are then split and release the energy in the form of heat.
- What are the advantages of nuclear power? Check all that apply.
  - Produces a small amount of waste
  - Nuclear power is very reliable
  - Nuclear power does not produce either smoke or carbon dioxide
  - Nuclear power is not expensive to make
- Which are the main nuclear fuels?
  - Uranium and plutonium
  - Uranium and tritium
  - Plutonium and tritium
- Which of the following sub-atomic particles is never found in the nucleus of an atom?
  - Neutron
  - Proton
  - Electron
- Nuclear power is a
  - non-renewable source of energy.
  - renewable source of energy.
  - a stable energy source.
- Fill in the blank spaces  
Nuclear ..... is the ..... of a heavy, unstable nucleus into two lighter nuclei, releasing vast amounts of energy.

Nuclear ..... is the process where two light nuclei ..... together releasing vast amounts of energy.

8. Describe the production of energy from nuclear sources.
9. Justify why nuclear energy is a non-renewable source of energy
10. Describe two problems caused by the use of nuclear energy.

### 4.3 Energy Transformations

As we learnt in S1, an energy transformation is the change of energy from one form to another. Examples of forms of energy include electrical, thermal, nuclear, mechanical, electromagnetic, sound, and chemical energy.

All energy transformations obey the **law of conservation** of energy that states that *energy cannot be created nor destroyed but simply changes from one form to another i.e. total energy in a closed system is conserved*. A device that converts energy from one form to another is known as a **transducer**.

#### 4.3.1 Examples of energy transformations

##### 4.3.1.1 Potential energy to kinetic energy and vice versa

##### Swinging Pendulum

#### Activity 4.9

To demonstrate transformation of P.E to K.E and vice versa

#### Materials:

- Clamp and stand
- 1 m of string
- Pendulum bob
- Calculator
- Weighing scale

#### Steps

1. Measure and record the mass,  $m$ , of the pendulum bob.
2. Tie the bob with a string and suspend it on a clamp with the string such that the bob is just about to touch the ground when hanging freely (See Fig. 4.14).
3. Pick an arbitrary vertical height at which you will release their pendulum.
4. Measure and record this height,  $h$ . Preferably it should range from 15 cm - 40 cm from the floor.
5. Calculate the potential energy of the bob at this height.
6. Release the pendulum bob from this height. Observe and explain what happens.



Fig. 4.14. A swinging pendulum

- 7 Discuss the following questions in your group:
  - (a) Where will the pendulum have the greatest potential energy?
  - (b) Where will it have the greatest kinetic energy?
8. Calculate the kinetic energy at the bottom of the swing.
9. Calculate the theoretical velocity,  $v$ , at the bottom of the swing.
10. Make short notes from your discussion and read them to the whole class.

At the highest point of swing, potential energy is maximum while kinetic energy is minimum (zero). When the pendulum bob is set to oscillate, the potential energy is transformed to kinetic energy.

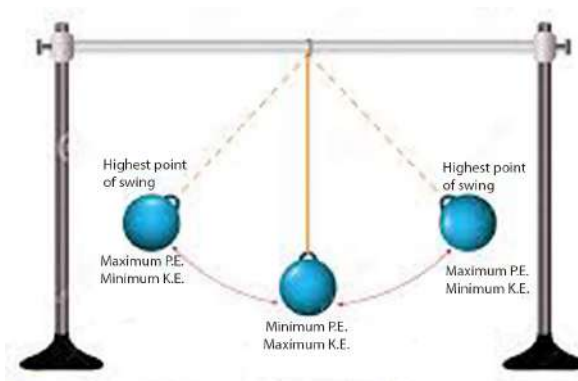


Fig. 4.15: Oscillating pendulum

When the bob is swinging, its speed is highest at its lowest point thus it has the maximum kinetic energy and zero potential energy due to its position. At the highest point, it has the maximum potential energy due to its position and zero kinetic energy.

#### 4.3.1.2 Conversion of electrical energy into mechanical energy and vice versa.

One device that converts electrical energy to mechanical energy is a motor. It actually converts electrical energy to kinetic energy.

#### Activity 4.10

#### To make a simple motor

##### Materials:

- Safety pins, nails (screws)
- Wood block
- Wire
- Sharp knife/razor blade
- Battery holder
- Disk magnet
- Scotch tape

##### Steps

Fig 4.16 Shows a simple electric motor that we are going to make following the steps below.



Figure 4.16. An electric motor

1. Wind a wire to form a coil (solenoid) on a pen, making 6 or 9 turns and leave some inches of wire free at each end.
2. Carefully, pull the coil off the pin (former) and make its shape permanent by wrapping it around the loop.
3. Hold the coil at the edge of a table so that the coil is straight up and down (not flat on the table) and one of the free wire ends lying on the table.

4. With a sharp knife, remove the top half of the insulation from the free wire end. Be careful to leave the bottom half of the wire with the enamel insulation intact. Do the same thing to the other free wire end.
5. Bend two safety pins from the middle.
6. Use nails (screws) to mount the bent safety pins on the wood block so that the loops face each other and are about 1 inch apart.
7. Attach the wires from the battery holder to the supports (bent safety pins).
8. Swing the safety pins apart a little and insert the coil into both rings.
9. Insert the battery into the holder. Place the magnet on top of the wood just underneath the coil. Make sure the coil can spin freely and it just misses the magnet.
10. Spin the coil (armature) gently. What do you observe?
11. Discuss the energy transformation in the simple motor

A device that converts mechanical energy into electrical energy is a **generator**. It uses the concept of **electromagnet induction** where electric current is induced in a conductor moving inside a magnetic field or a conductor cutting through magnetic field linking two points.

#### Activity 4.11

#### To demonstrate transformation of mechanical energy to electrical energy

##### Materials:

- Galvanometer
- Coil (solenoid)
- Insulated copper wire
- Connecting wires
- Bar magnet

##### Steps

1. Make a coil (solenoid) using an insulated copper wire.
2. Connect the ends of the solenoid using connecting wires to a sensitive galvanometer.
3. Quickly introduce (push) the bar magnet into the solenoid and stop (Fig. 4.17(a)).
4. Withdraw the magnet quickly from the coil and stop (Fig. 4.17(b)).



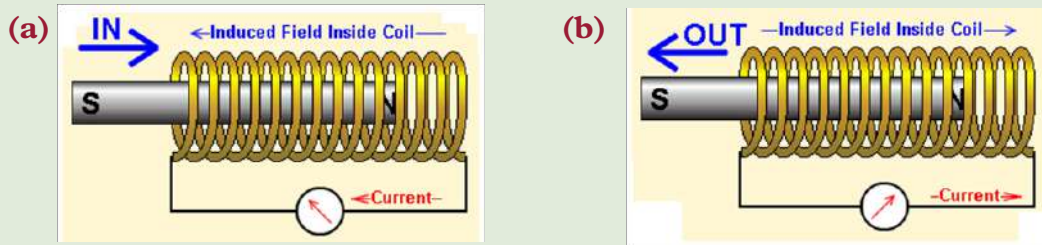


Fig 4.17: Mechanical energy being transformed into electrical energy.

- Move both the bar magnet and the coil at the same speed and in the same direction. Observe and explain what happens to the galvanometer.

### Exercise 4.4

For questions 1 - 6, select the most suitable response from the choices given

- What energy transformation takes place in a toaster? Discuss.
  - Mechanical  $\rightarrow$  electrical
  - Electrical  $\rightarrow$  thermal
  - Thermal  $\rightarrow$  chemical
- What energy transformation takes place when an object burns?
  - Chemical  $\rightarrow$  thermal
  - Electrical  $\rightarrow$  mechanical
  - Electromagnetic  $\rightarrow$  chemical
- You notice that after you walk across a room, you feel a spark when you touch the doorknob. What energy transformation must have taken place?
  - Thermal  $\rightarrow$  electromagnetic
  - Mechanical  $\rightarrow$  electrical
  - Electromagnetic  $\rightarrow$  mechanical
- In what state is chemical energy always in?
  - Kinetic
  - Potential
- When a turbine rotates to produce electricity, what energy transformation takes place?
  - Thermal  $\rightarrow$  mechanical

- (b) Electrical → electromagnetic
  - (c) Chemical → electrical
  - (d) Mechanical → electrical
6. What type of energy is produced and wasted during most energy transformations?
- A. Chemical
  - B. Thermal
  - C. Electrical
7. Fig 4.18 shows a clock



Fig.4.18 : a clock

Use the correct words from the following to fill the blank spaces in the paragraph below them.

*Chemical, electrical, kinetic, light, sound, thermal*

The battery stores \_\_\_\_\_ energy. When the battery is first connected, electrical energy is transferred to \_\_\_\_\_ energy of the clock’s hands. Some of the electrical energy is transferred to the surrounding as \_\_\_\_\_ energy. When the alarm bell rings, electrical energy is transferred to \_\_\_\_\_ energy.

8. Match

Transducer
bulb
Guitar wire
Athlete running
candle
motor
A battery in use
Hot air balloon

Energy transformation
Electrical to mechanical
Chemical to light and thermal
Chemical to electrical
Chemical to mechanical
Thermal to mechanical
Electrical to light
Mechanical to sound

9. A stone is thrown into the air. Explain the energy changes taking place from the moment it is thrown to the moment it falls back to its starting point
10. Uwimana a student in Senior three has a bicycle with a motor lighting system. Explain the energy transformation within the system.
11. Discuss the energy transformation in Rusumo hydroelectric power station.

### Unit summary and new words

- Energy sources fall into two categories: non-renewable and renewable.
- Non-renewable energy sources, like coal, nuclear, oil, and natural gas, are available in limited supplies. They take a long time for them to be replenished.
- Renewable sources are replenished naturally and over relatively short periods of time. The five major renewable energy sources are solar, wind, water (hydro), biomass, and geothermal.
- Since the dawn of humanity people have used renewable sources of energy to survive — wood for cooking and heating, wind and water for milling grain, and solar for lighting fires.
- Fossil fuels include oil, natural gas, and coal. They formed from the buried remains of plants and animals. They are non-renewable energy sources. They can be burned to supply energy for generating electricity.

#### Other renewable energy sources

- Tidal energy, wind energy and geothermal energy can be converted into electrical energy in generators.

#### Nuclear power plants

- Nuclear reactors use the energy released in the fission of U-235 to produce electricity.
- The energy released in the fission reaction is used to make steam. The steam drives a turbine that rotates an electric generator.

#### The risks of nuclear energy

- Nuclear power generation produces high-level nuclear wastes.
- Organisms could be damaged if radiation is released from the reactor.

- Nuclear waste is the radioactive by-product produced by using radioactive materials.

### **Energy transformation**

- Energy can be transformed from one form to the other. For example in a pendulum; potential energy → kinetic energy → potential energy, in a motor; mechanical energy → electrical energy.
- Photovoltaic cells, or solar cells, convert radiant energy from the sun into electrical energy.
- Hydroelectric power plants convert the potential energy in water to electrical energy.

## **Unit Test 4**

**For questions 1 - 10, select the question that you think it is right.**

1. Energy sources that once used can replenish themselves and can be used again and again are termed as  
**A.** Non-renewable                      **B.** Renewable  
**C.** Finite                                      **D.** Kinetic
2. Which of the energy sources listed is not a renewable source of energy  
**A.** Oil    **B.** Solar  
**C.** Wind    **D.** Tidal  
**(e)** Geothermal
3. What is the other name for non-renewable  
**A.** Non-renewable                      **B.** Finite  
**C.** Infinite
4. Energy sources that once used cannot be replenished are called;  
**A.** Non-renewable                      **B.** Renewable  
**C.** Infinite                                      **D.** Potential  
**E.** Kinetic
5. What natural source is harnessed to generate hydro-electric power (HEP)?  
**A.** Wind    **B.** Water  
**C.** Light    **D.** Heat

6. What is the other name of the renewable energy source generated from using volcanic heat found under the earth's surface?
  - A. Wind
  - B. Hydro-electric power (HEP)
  - C. Tidal
  - D. Solar
  - E. Geothermal
7. What is the name of the renewable energy supply generated by capturing sunlight in panels that convert the sunlight into electricity?
  - A. Wind
  - B. Hydro-electric power
  - C. Tidal
  - D. Solar
  - E. Geothermal
8. Which statement below is not an advantage of tidal energy?
  - A. Tidal barrages have the potential to generate a lot of energy
  - B. Tidal barrages can double as bridges
  - C. Tidal barrages can help to prevent flooding
  - D. Tidal energy is renewable and once in use can be used for generations
9. What type of energy source comes from radioactive minerals such as uranium and releases energy when the atoms of the radioactive minerals are split by nuclear fission?
  - A. Biomass
  - B. Natural gas
  - C. Geothermal
  - D. Hydro-electric power
  - E. Nuclear
10. What type of energy source is formed from fossilized plants and is found sandwiched between other types of rock in the earth?
  - A. Oil
  - B. Coal
  - C. Geothermal
  - D. Biomass
  - E. Nuclear
11. Describe the advantages and disadvantages of using fossil fuels to generate electricity.
12. Describe how fossil fuels are formed.
13. Name three compounds that are formed from the chemical compounds in petroleum.
14. If fossil fuels are still forming, why are they considered to be a nonrenewable resource?

- 15.** Solar energy has provided almost all the sources of energy on the earth. Explain.
- 16.** Explain two advantages and two disadvantages of using solar energy.
- 17.** Explain why geothermal energy is unlikely to become a major energy source?
- 18.** Describe three ways solar energy can be used.
- 19.** Explain how the generation of electricity by hydroelectric, tidal, and wind sources are similar to each other.

## UNIT

## 5

## Heat Transfer and Quantity of heat

**Key Unit Competence**

By the end of the unit, the learner should be able to evaluate modes of heat transfer and determine specific heat capacity of metal block.

**Learning objectives****Knowledge and understanding**

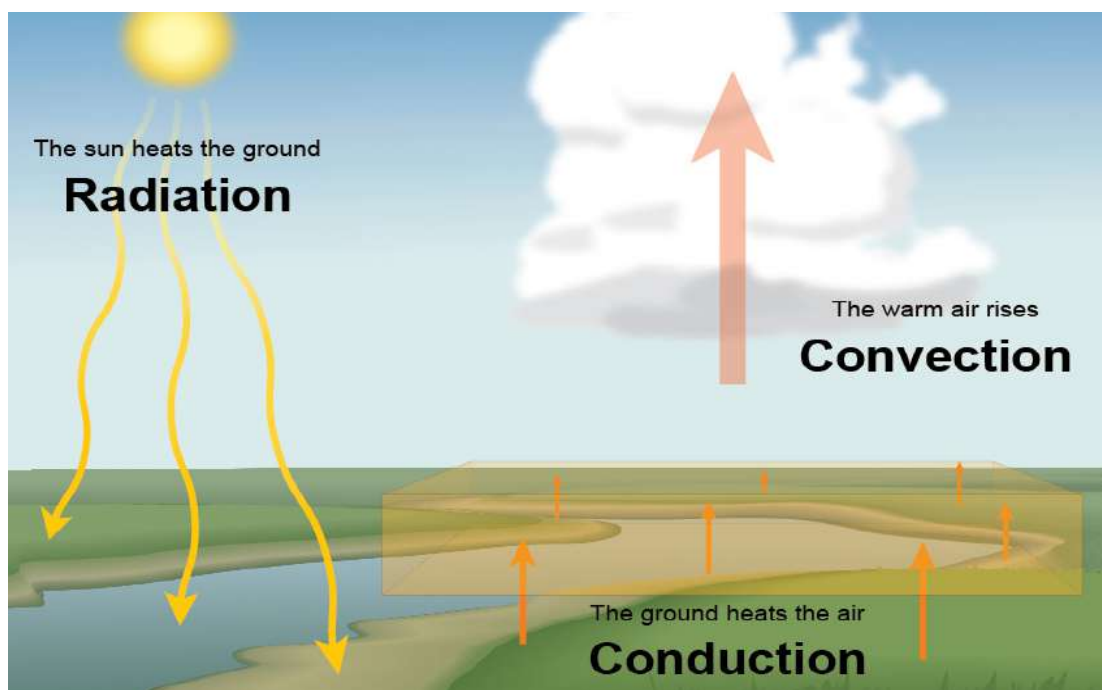
- Recall the differences between heat and temperature.
- Explain modes of heat transfer.
- Explain thermal expansion of solids.
- Explain applications of heat exchanges.
- Explain thermal expansions.
- Define the terms heat capacity and specific heat capacity.
- Describe experiments to determine specific capacity of a metal.
- Determine coefficient of expansion.

**Skills**

- Apply knowledge of heat capacity to predict the behaviour of different materials as temperature is changed.
- Describe different modes of heat exchange.
- Calculate heat capacity, specific heat capacity, latent heat, specific latent heat
- Carry out an investigation that illustrates heat exchange.
- Analyse experiments on thermal expansion of solids.
- Differentiate linear surface and volume expansion of different object.

**Attitude and value**

- Appreciate application of modes of heat transfer.
- Acquire knowledge in analyzing the behaviour of materials under thermal expansion.
- Be aware of difficulties related to heat exchanges.



## Introduction

### Unit Focus Activity

Fig 5.1 below shows a person heating some liquid in saucepan over an electric coil.

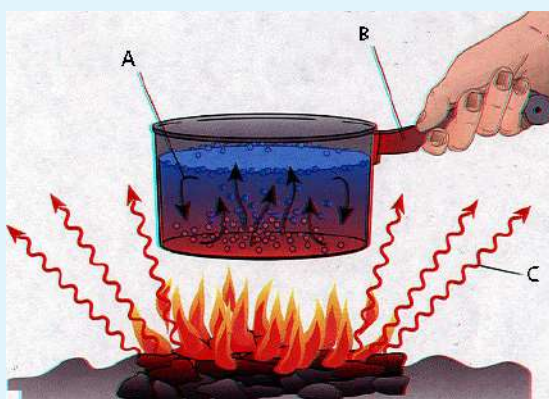


Fig. 5.1: Heating some liquid in a saucepan

1. Identify the modes of heat transfer marked A, B and C.
2. Discuss how each of the modes of heat transfer takes place, citing the states of matter through which the processes take place.
3. Describe one application of each type of the above modes of heat transfer in real life.
4. Present your findings to the rest of the class in a class discussion.



In our environment, most interactions between systems involve transfer of heat from one system to another. For example, when we bask in the sun, we feel warmer, when we touch a hot sauce pan, we feel the heat. In this unit, we are will discuss the different modes through which heat is transferred from one region to another. We will begin by reviewing the difference between heat and temperature.

## 5.1 Heat and temperature

The following activity will enable us to understand the difference between heat and temperature.

### Activity 5.1

### To investigate the difference between heat and temperature

#### Materials

- A measuring cylinder
- A beaker
- Cooking oil (about 200 g)
- Bunsen burner (source of heat)
- 2 thermometers
- Two identified test tubes
- A stirrer
- Water
- 2 clamps and stands

#### Steps

1. Take equivalent masses of water and cooking oil in two identical test tubes fitted with two identical thermometers. Place these tubes in a large beaker containing water i.e water bath (Fig. 5.2).

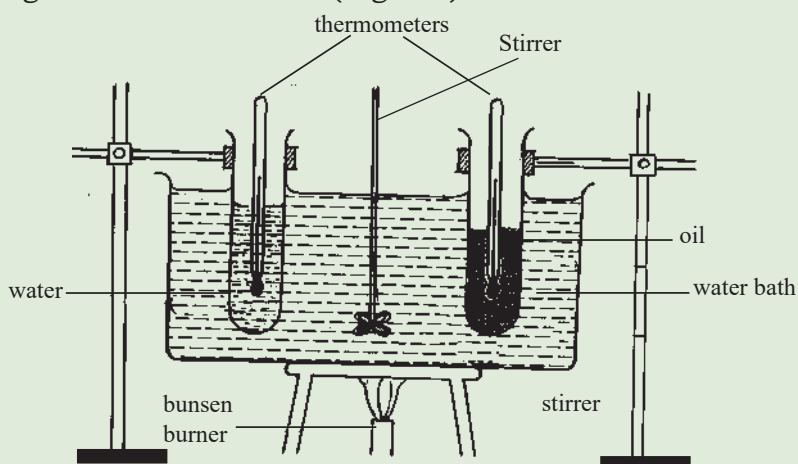


Fig. 5.2: Differences between heat and temperature

2. Record the initial temperature of both water and oil in the tubes.
3. Heat the water in the beaker and make sure that the heat is distributed uniformly by stirring the water. After some time, note the temperature reading of water and oil in the tubes. Are the two temperature reading the same? Explain.

When the same amount of heat energy is supplied to equal masses of two different substances, that are initially at same temperature, they both gain equal amounts of heat energy but their temperature rise to different values.

Heat is a form of energy that flows from a hot to a cold body while temperature is the degree of hotness or coldness of a substance.

## 5.2 Modes of heat transfer

### Activity 5.2

#### To describe the modes of heat transfer

Revisit the unit focus activity and differentiate between the three modes of heat transfer.

### 5.2.1 Heat transfer by conduction

#### 5.2.1.1 Demonstration of conduction of heat

The following experiment will illustrate conduction of heat in solids.

### Activity 5.3

#### To investigate heat transfer in solids

#### Materials:

- A metal spoon
- Bunsen burner
- A beaker full of boiling water
- Wax

#### Steps

1. Take a metal spoon at room temperature. Dip the spoon (with the other end waxed) into a beaker full of boiling water (Fig. 5.3). After a few minutes, what do you observe? Touch the free end of the metal spoon outside water. What do you feel? Explain.

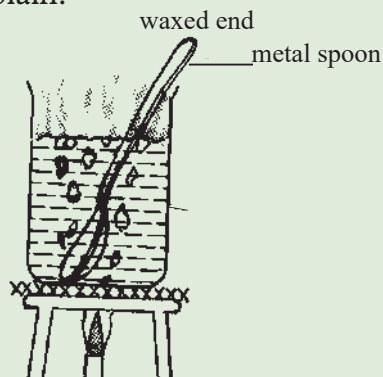


Fig. 5.3: A spoon inside boiling water

2. Discuss how heat is transferred by conduction.

Solids transfer heat from one point to another. For instance, the free end of the spoon outside the beaker in Fig. 5.3 has become hot. Heat energy has been transferred from the inside to the outside through the metal spoon i.e. from a region of *higher temperature* to a region of *lower temperature*.

This process of transfer of heat energy in solids is called *conduction*. Conduction is the transfer of heat from one substance to another that is in direct contact with it. In conduction there is no visible movement of the heated particles.

### 5.2.1.2 Mechanism of conduction of heat

We have already learnt that when temperature increases, the molecules have larger vibrations. This knowledge can help us understand the mechanism of conduction of heat. When the molecules at one end of a solid receive heat energy from the heat supply, they begin to vibrate vigorously. These molecules collide against the neighbouring molecules and agitate them. The agitated molecules, in turn, agitate the molecules in the next layer and so on till the molecules at the other end of the solid are agitated. Thus, the heat is passed from one point to another till the other end becomes hot. Hence, in *conduction*, energy transfer takes place by vibration of the molecules. There is no actual movement of the heated particles.

#### Activity 5.4

To demonstrate that heat energy flows due to a temperature difference

#### Materials:

- An iron bar about a metre long with holes drilled at equal intervals
- Oil
- Thermometer
- Wooden screen
- Water bath
- A bunsen burner
- Hammer
- Metal punch

#### Steps

1. Fill the holes of the iron bar partially with oil and insert the bulb of the thermometers into them. Note the readings of the thermometers.
2. Heat one end of the iron bar slowly and gradually (Fig. 5.4). Observe the temperature increase in the thermometers and record the readings.

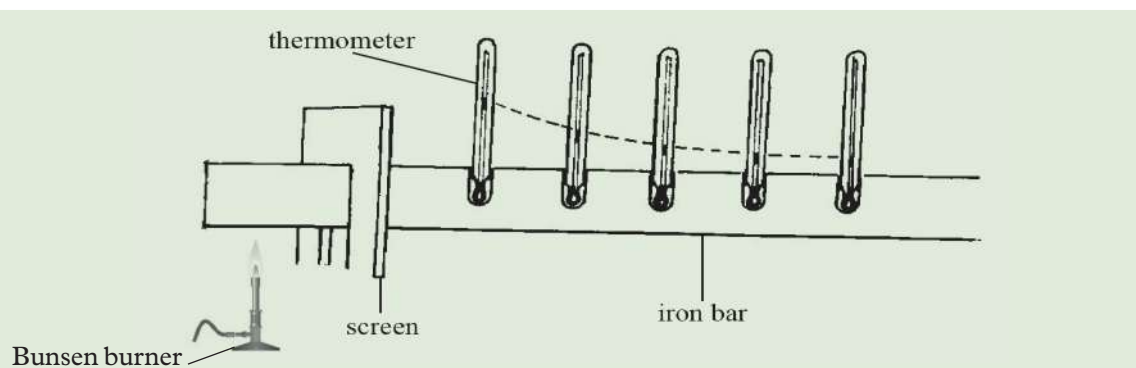


Fig. 5.4: The higher the temperature difference the higher the energy transferred

- After some time, note the temperature readings of the thermometers. What do you observe? Explain.

The thermometer nearest to the hot bunsen burner registers the highest rise in temperature, and the one farthest away registers the least temperature rise.

Initially the readings of all the thermometers were the same. When one end of the rod was inserted into boiling water, a large temperature difference was set up between the two ends and heat energy flowed from the region of higher temperature to that of lower temperature. Hence heat energy flows due to *temperature difference*.

If the activity is repeated by replacing the hot water bath with a bunsen burner flame (temperature of the bluish part of the flame is about  $500^{\circ}\text{C}$ ), the rise in temperature registered by each thermometer is higher. Hence the higher the temperature difference, the higher the energy transfer.

Heat energy flow in solids is due to temperature difference. The higher the temperature difference, the higher the energy flow.

### 5.2.1.3 Comparing rates of conduction in metals

#### Activity 5.5

To show that heat transfer in solids depends on the material

#### Materials:

- A copper rod
- Iron rod
- Aluminium rod
- 3 match sticks
- Wax
- Tripod stand
- A bunsen burner

#### Steps

- Take three rods, copper, aluminium and iron of the same length and thickness. Fix a matchstick (or a light metal pin) to one end of each rod using a little melted wax.
- Place the rods on a tripod stand and heat the free ends with a burner as shown in Fig. 5.5. Observe what happens.

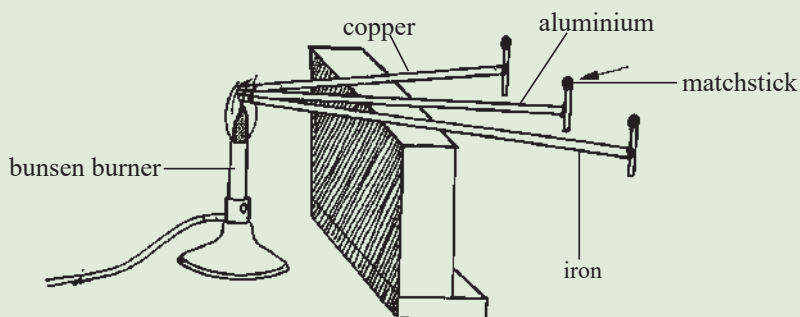


Fig. 5.5: Comparing heat transfer through different conductors

The matchstick falls off from the copper rod first then aluminium and finally from the iron rod.

When the temperatures of the other ends of the rods reach the melting point of wax, the matchstick falls off. The matchsticks do not fall off at the same time, because the energy transferred is not equal for all the rods. The matchstick from the copper rod is the first one to fall off showing that of the three metals, copper is the best conductor of heat followed by aluminium and then iron.

## 5.2.2 Heat transfer by convection

### 5.2.2.1 Convection in liquids

#### Activity 5.6

#### To observe convection current in water

##### Materials

- A long straw
- A beaker containing water
- A crystal of potassium permanganate
- A bunsen burner

##### Steps

1. With the help of a long straw, drop a small crystal of potassium permanganate to the centre of the bottom of a flask or a beaker containing water. What do you observe?
2. Heat the flask gently at the centre of the flask (Fig. 5.6). Observe what happens.

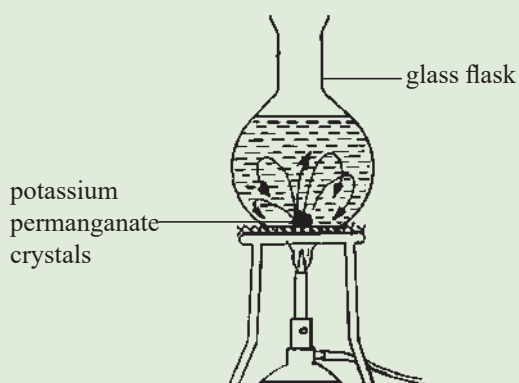


Fig. 5.6: Convection currents in water

Coloured streaks are observed to rise from the bottom to the top.

The crystal dissolves and the hot water of less density starts rising displacing the cold dense water down. The streams of physically moving warm liquid are called *convection currents*.

Heat energy is transferred by the convection currents in the liquid. The transfer of heat by this current is called *convection*.

### 5.2.2.2 Convection in gases

#### Activity 5.7

#### To observe convection current in air

##### Materials:

- A box with a glass window, and two chimneys
- A candle
- Smouldering pieces of wick

##### Steps

1. Take a box with a glass window and two chimneys fixed at the top.
2. Place a lighted candle under one chimney and hold a smouldering piece of wick above the other chimney as shown in Fig. 5.7. What do you observe?

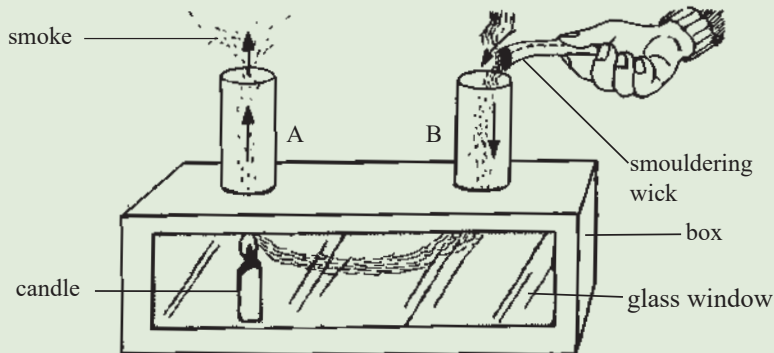


Fig. 5.7: Convection currents in air.

Smoke from the smoldering wick is seen to move down through chimney B then to the candle flame and finally comes out through chimney A.

Air above the candle flame becomes warm and its density decreases. Warm air rises up through chimney A and the cold dense air above chimney B is drawn down this chimney and passes through the box and up the chimney A. The smoke particles from the wick enable us to see path of convection current (Fig. 5.7).

Heat is transferred in air through convection currents. This convection current passes energy as shown in Activity 5.8.

**Activity 5.8****To illustrate that convection currents possess energy****Materials:**

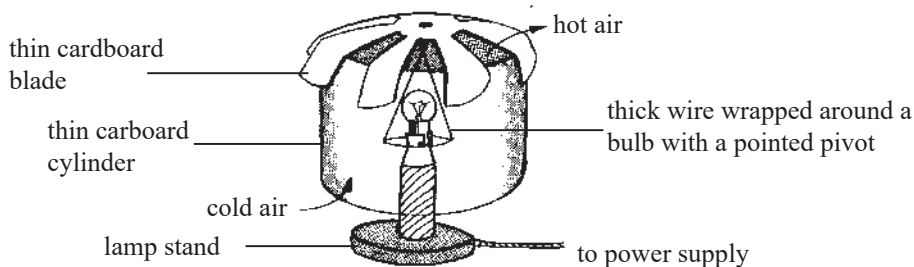
- A thin circular disk
- A card board
- A candle flame

**Steps**

1. Take a thin circular disk of tin or cardboard and cut out six blades all round (Fig. 5.8(a)). Pivot the disk on a bent needle (Fig. 5.8(b)).
2. Hold the disk above the candle flame for some time. Watch what happens.

*Fig. 5.8: A rotating disk.*

The disk starts to rotate. The rotation is due to the convection current set up. If a powerful electric bulb is available, you can make a rotating lamp shade.

*Fig. 5.9 : A rotating lamp shade*

Convection currents possess energy. It is for this reason that steam is used to rotate the turbine in geothermal electric plants.

**5.2.3 Heat transfer by radiation****5.2.3.1 The concept of radiation**

If you stand in front of a fireplace, you feel your body becoming warm. Heat energy cannot reach you by conduction as air is a poor conductor of heat. How

about convection? The hot air molecules in and around the fireplace can only rise and do not reach you by convection. How does the energy from the fireplace then reach you? Heat energy must be transferred by a different mode other than conduction and convection.

### Activity 5.9

### To demonstrate heat transfer by radiation

#### Materials:

- A thin tin lid painted black
- Wax
- A thumb tack
- A bunsen burner

#### Steps

1. Take a thin tin lid painted black on one side. Stick a thumb tack with melted wax on the other side.
2. Keep the bunsen burner flame close to the painted side (Fig. 5.10). What happens? Explain.

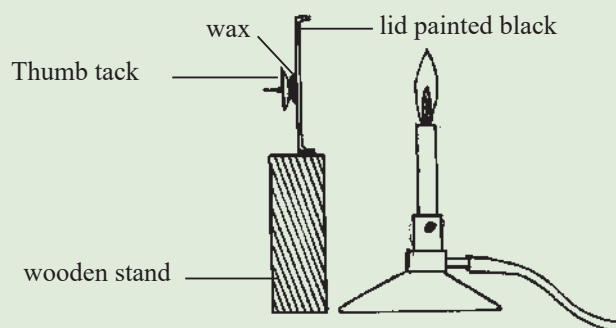


Fig. 5.10: Radiation

As discussed in the case of the fireplace, the energy from the flame reaches the tin lid and the wax by a different mode other than conduction and convection. This third mode of heat transfer is called *radiation*. Radiation is the emission or transmission of energy in the form of a wave or particles through a material or space. Heat transfer from the sun travels through empty space (vacuum) and reaches the Earth. This energy is transferred by radiation. The surfaces of all luminous bodies emit radiation. A human face also emits some mild radiations. While conduction and convection need a medium to be present for them to take place, radiation can take place without a medium.

The amount of heat energy radiated depends upon the temperature of the body. In Activity 5.9, if the bunsen burner is replaced by a candle flame, it will take a longer time for the wax to melt. The temperature of the candle flame is lower than that of a bunsen burner.

Heat transfer can take place without contact or in a vacuum. This method of heat transfer is called *radiation*.



### 5.2.3.2 Good and bad absorbers of heat energy by radiation

#### Activity 5.10

#### To illustrate good and bad absorbers of heat

##### Materials:

- Two thin tin lid
- Molten wax
- A metal thumb tack (match stick)
- A bunsen burner

##### Steps

1. Take two thin tin lids, one with the inner side shiny and the other with the inner side painted dull black.
2. Stick metal thumb tacks (or match sticks) on the outside of each lid using a little molten wax.
3. Keep a bunsen burner flame midway between the lids as shown in Fig. 5.11. Watch closely to and compare what happens to the two thumb tacks. Explain your observation.

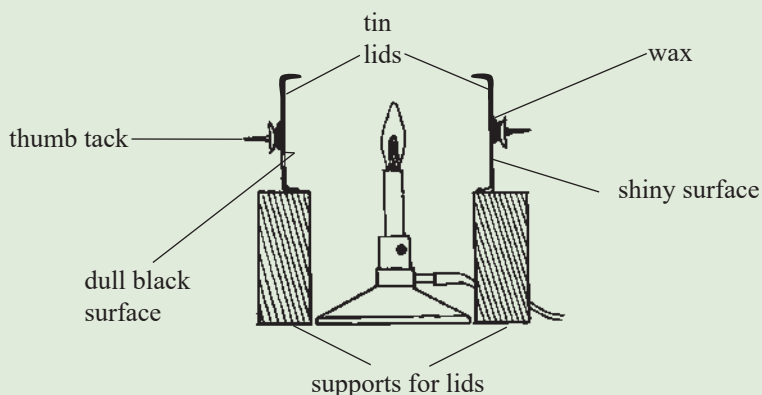


Fig. 5.11: Good and bad absorbers

If a black and shiny surface receive the same amount of heat energy by radiation, the black surface *absorbs* more heat than the shiny surface.

A dull black surface is a better *absorber* of heat radiation than a shiny surface.

#### Activity 5.11

#### To illustrate good and bad emitters of heat

##### Materials

- Three thermometers
- Three identical empty cans
- Three cardboard

##### Steps

1. Take three identical empty cans of the same volume with their tops removed. Apply clean and dry paints one white and the other black on two cans (both

- inside and out surfaces) and leave the third can shiny.
2. Prepare three suitable cardboard covers with holes at the centre. Fill the cans to the brim with hot water at  $60^{\circ}\text{C}$ .
  3. Cover the cans with cardboards and place a thermometer in each can through the hole at the centre of the cardboard (Fig. 5.12).

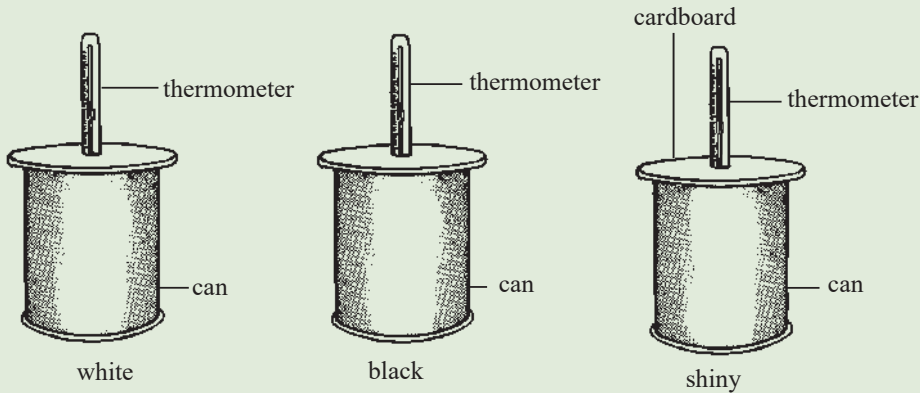


Fig. 5.12: Good and bad emitters

4. Record the temperature of water in the cans after a certain time interval. Which can cools the water fastest? Which can takes the longest time to cool the water? Explain the difference in the rate of temperature drop in the three cans.

A shiny surface is a good emitter than a dull black surface

### 5.2.4 Applications of heat transfer

#### Activity 5.12

To describe the applications of heat transfer

#### Materials

- Internet
- Reference books

#### Steps

1. You have learnt about heat transfer. Without referring to this book or any other source, describe three ways in which heat transfer is important in our daily lives.
2. Do a research from the internet and reference books on the applications of heat transfer.
3. In your research, highlight clearly how the modes of heat transfer are applied in vacuum flasks, construction of ventilations, domestic hot water system and solar heating.

4. What other applications of heat transfer did you come across in your research.
5. Explain to your group members how natural phenomena like sea and land breeze take place.
6. Make a presentation on your findings to the whole class through your group secretary.

## 1. Vacuum flask

The vacuum flask popularly known as *thermos flask*, was originally designed by *Sir James Dewar*. It is designed such that heat transfer by conduction, convection and radiation between the contents of the flask and its surroundings is reduced to a minimum.

A vacuum flask, Fig. 5.13 is a double-walled glass container with a vacuum in the space between the walls. The vacuum minimises the transfer of heat by conduction and convection. The inside of the glass walls, is silvered so as to reduce heat losses by radiation. The felt pads on the sides and at the bottom support the vessel vertically. The cork lid is a poor conductor of heat.

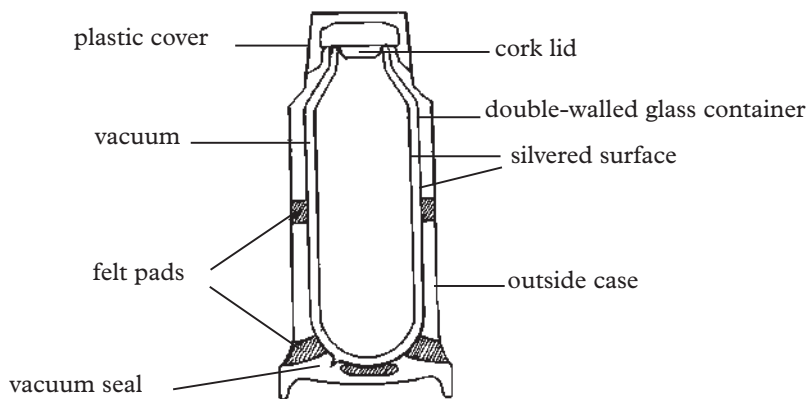


Fig. 5.13: Vacuum flask

When the hot liquid is stored, the inside shiny surface does not radiate much heat. The little that is radiated across the vacuum is reflected back again to the hot liquid, by the silvering on the outer surface. There is however some heat lost by conduction through the walls and the cork.

## 2. Windows and ventilators in buildings

As shown in Fig. 5.14, warm exhaled air of less density goes out through the ventilator and fresh air of high density enters through the windows at a lower level. This refreshes the air in a room.

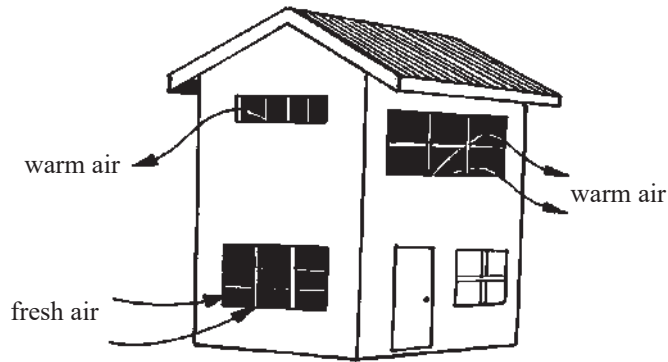


Fig. 5.14: Ventilation in building

### 3. Natural convection currents over the earth's surface

#### (a) Sea breeze

During the day, the temperature of the land rises faster than the temperature of sea water and the air over the land becomes warmer than the air over the sea water. The warm air of less density rises from the land allowing the cold dense air over the sea to blow to the land. This creates a *sea breeze* in the daytime (Fig. 5.15).

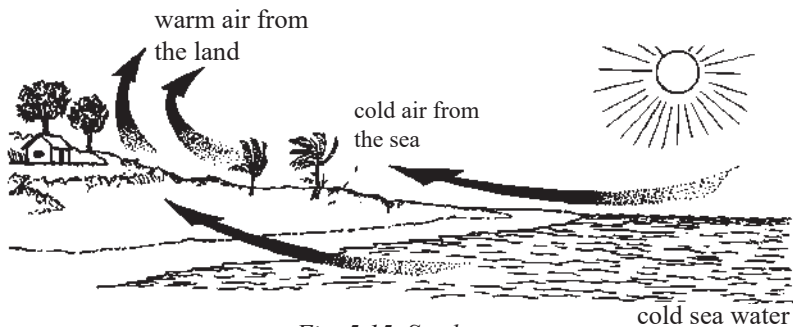


Fig. 5.15 Sea breeze

#### (b) Land breeze

During the night, the land cools faster than the sea water. Warm air from the sea rises and the dense air from the land moves to the sea. This sets up a land breeze in the sea (Fig. 5.16).

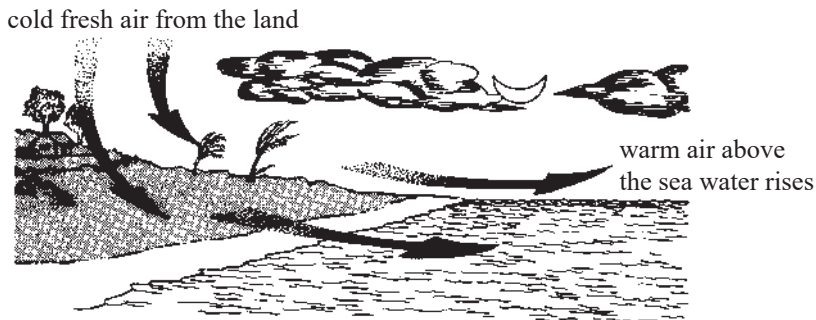


Fig. 5.16: Land breeze

#### 4. Electrical devices

An electric kettle has its heating coil at the bottom. A refrigerator has the *freezing unit* at the top.

#### 5. Domestic hot water system

A domestic hot water supply system works on the principle of convection current. A schematic diagram of a hot water supply is shown in Fig. 5.17.

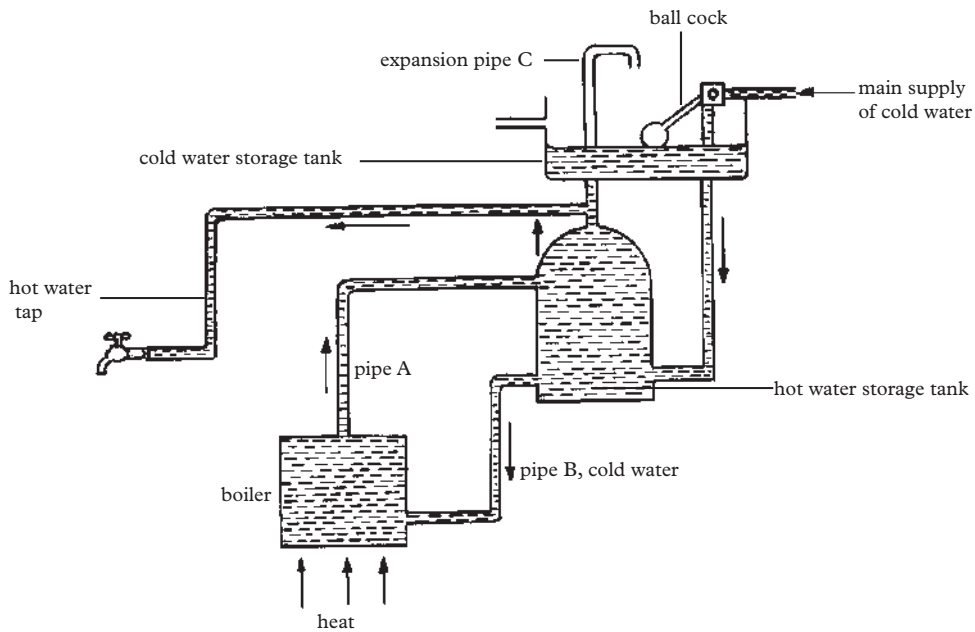


Fig. 5.17: Hot water system

Water is heated using fire wood, oil or electricity in the boiler. Hot water from the boiler goes up to the hot water storage tank through pipe A. Cold water flows down from the cold water storage tank into the boiler through pipe B (called return pipe).

When the hot water is being drawn from the top of the hot water storage tank, it is replaced by water from the main cold water tank built at the top of the house. The expansion pipe C allows steam and dissolved air to escape. This ensures that the tank does not explode due to the pressure created by the steam produced.

#### 7. Solar heating

Flat plate collectors, called *solar panels*, are used to heat water. They can heat water up to  $70^{\circ}\text{C}$ . A solar panel consists of thin copper pipes, painted black, which carry the water to be heated. These tubes are fitted in a copper collector plate which in turn is fitted on to a good thermal insulator in a metal frame. A glass plate covers the panel (Fig. 5.18). These panels can be fitted on the roof of houses.

Heat radiation from the sun falls on the tubes and on the collector plate through the glass plate. The heat radiations trapped inside the panel by the glass plate heat the water. The hot water is then pumped to a heat exchange coil in a hot water tank which is connected to the domestic hot water system.

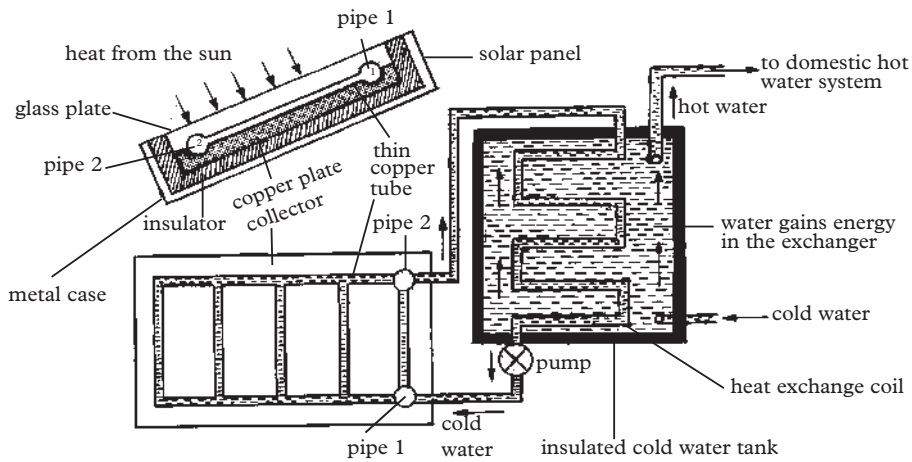


Fig. 5.18: Solar heating

## 8. Solar concentrations

In some heating devices, instead of a flat plate collector, curved mirrors (concave or parabolic) are used to concentrate the heat radiations from the sun to a small area at their focus. If the boiler is placed at the point of focus, very high temperatures can be reached.

### Exercise 5.1

1. Distinguish between *heat* and *temperature*.
2. What are the different modes of heat transfer? Explain clearly their difference using suitable examples.
3. State three factors which affect heat transfer in metals. Explain how one of the factors you have chosen affects heat transfer.
4. Describe an experiment to show that water is a poor conductor of heat.
5. Use particle behaviour of matter to explain conduction.
6. Describe a simple experiment to demonstrate that the heat radiated from a hot body depends upon the temperature of the body.
7. With a suitable diagram, explain the working of a vacuum flask.

## 5.3 Thermal expansion

In general, nearly all substances increase in size when heated. The process in which heat energy is used to increase the size of matter is called *thermal expansion*. The increase in size on heating of a substance is called *expansion*. On cooling,

substances decrease in size. The decrease in size on cooling of a substance is called *contraction*. Why is this so?

### 5.3.1 Thermal expansion and contraction in solids

When a solid (e.g. a metal) is subjected to heat, it:

- (a) Increases in length (Linear Expansion).
- (b) Increases in volume (Volume Expansion).
- (c) Increases in area (Surface Expansion).

#### 5.3.1.1 Linear expansion

##### (a) Demonstrations of linear expansion

#### Activity 5.13

To demonstrate expansion and contraction using the bar and gauge apparatus

#### Materials

- A bar and gauge apparatus
- Bunsen burner

#### Steps

1. Move the metal bar in and out of the gauge at room temperature (Fig. 5.19). Observe what happens.

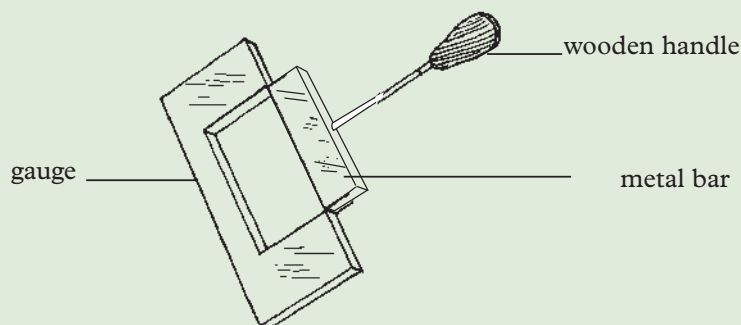


Fig. 5.19: Bar and gauge apparatus

2. Keep the metal bar away from the gauge and heat the bar for sometime.
3. Try to fit the bar into the gauge and observe what happens. Explain your observation.
4. Allow the bar to cool and try to fit it into the gauge. What happens? Explain.

A bar and gauge apparatus consists of a metal bar with a suitable wooden handle and a gauge. When both the metal bar and the gauge are at room temperature, the bar just fits into the gauge.

On heating, the metal bar expands. There is an increase in length. It hence expands

linearly and therefore, the bar cannot fit into the gauge.

On cooling the bar easily fits into the gauge due to contraction.

Solids expand i.e increase in length on heating and contract i.e reduced in length on cooling.

### Activity 5.14

### To demonstrate the bending effect of expansion and contraction

#### Materials

- A bimetallic strip
- Bunsen burner

#### Steps

1. Observe a bimetallic strip at a room temperature (Fig. 5.20).

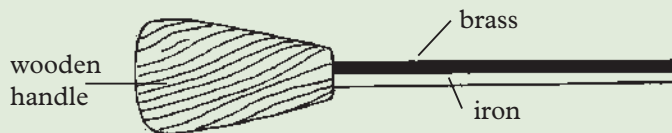
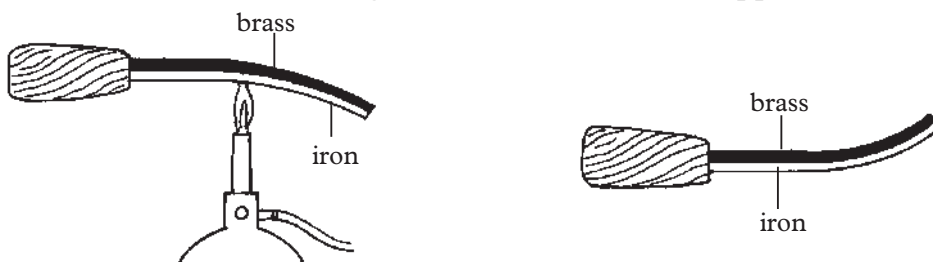


Fig. 5.20: A bimetallic strip

2. Take the bimetallic strip with the brass strip at the top and heat it with a bunsen burner flame for sometime. Observe what happens. Explain the observation.
3. Remove the flame and allow the bar to cool to a room temperature. Observe and explain what happens.
4. Discuss with your friend what will happen if the bar is cooled below room temperature. Sketch the strip at that temperature.

When the bimetallic strip is heated, it bends downwards with the brass strip on the outer surface of the curvature, as shown in Figure 5.21 (a). Why does this happen? When the flame is removed and the strip left to cool to room temperature, the strip returns back to its initial state (straight) as shown in Figure 5.20 above.

If the strip is cooled below room temperature, it bends upwards with the iron strip underneath as shown in Figure 5.21 (b). What has happened?



- (a) Heating the bimetallic strip      (b) Cooling the bimetallic strip below room temperature

Fig. 5.21: Bending effect of expansion and contraction



As the bimetallic strip is heated, brass expands more than iron. The large force developed between the molecules of brass forces the iron strip to bend downwards. On cooling below a room temperature, the brass contracts more than iron and the iron strip is forced to bend upwards.

The force developed during expansion or contraction causes a *bending* of the metals.

### (b) Comparison of rates of expansion of different solids

As we know from the kinetic theory of matter, the different states of matter expands when heated but at different rates.

The following activity shows that different solids have different rates of expansion.

#### Activity 5.15

#### To compare rates of expansion and contraction of different solids

##### Materials:

- Thin metal rods of different materials
- Source of heat
- Rollers connected to a pointer
- G - clamp

##### Steps

1. Clamp one end of a long thin metal rod tightly to a firm support, with the end of the rod resting on a roller fitted with a thin pointer (See Fig. 5.22).

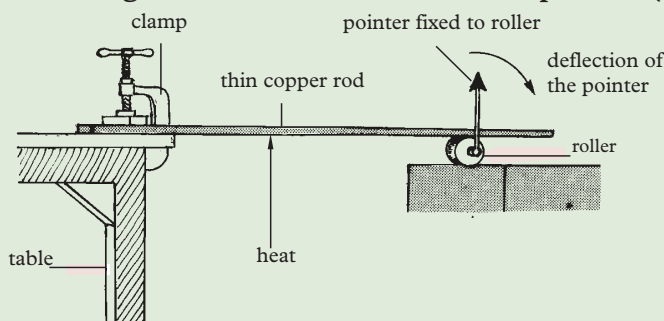


Fig. 5.22: Expansion and contraction of thin metal rods.

2. Heat the metal rod for sometime. Observe and explain what happens.
3. Remove the burner and allow the rod to cool. Observe and explain what happens.
4. Repeat the activity with thin rods of different materials. Observe and explain what happens, accounting for any differences.

The pointer deflects in the clockwise direction on heating and in the anticlockwise direction on cooling.

The pointer deflects to different extents depending on the material.

On heating, there is an increase in length (linear expansion) of the rods. The expanding rod moves the roller to the right making the pointer attached to the roller to deflects in a clockwise direction. On cooling, the rod contracts and decrease in length. The contracting rod moves the roller to the left hence the pointer deflects in the opposite direction (anticlockwise direction).

When a different material e.g lead is used, the pointer deflects more to the right (clockwise). When cooled, the pointer deflects more to the left (anticlockwise).

Different solids (e.g metals) expand and contract to different extents when heated by the same quality of heat.

### (c) Coefficient of linear expansion

Consider a thin metal of length  $l_0$ . in Fig. 5.23.

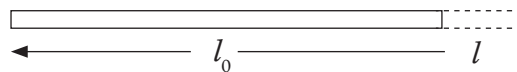


Fig. 5.23: A thin rod showing increase in length.

When the rod is heated, a temperature change of  $\theta$  occurs and its length increases by  $l$ .

The ratio of increase or decrease in length to original length  $\left(\frac{l}{l_0}\right)$  is directly proportional to the change in temperature  $\theta$ .

$$\frac{l}{l_0} \propto \theta \quad \Rightarrow \quad \frac{l}{l_0} = \alpha \theta \quad \text{and} \quad \alpha = \frac{l}{l_0 \theta}$$

**Note**  
 $\propto$  – proportionality sign  
 $\alpha$  – alpha-constant symbol

where  $\alpha$  is a constant called the **coefficient of linear expansion**. It is the value of the increase in length per unit rise in temperature for a given material. The SI units of  $\alpha$  is  $\text{K}^{-1}$

Suppose: The temperature change =  $\theta$ ,

$l_0$  represents the original length of the rod

$l$  represent the new length for a temperature rise of  $\theta$

Then,  $\Delta l = l - l_0$

The above expression may be expressed in terms of  $l_0$ ,  $l$ ,  $\theta$  and  $\alpha$  as follows.

$$\alpha = \frac{l}{l \theta} = \frac{l - l_0}{l \theta} \quad \text{Rearranging} \quad l - l_0 = l_0 \alpha \theta$$

$$l = l_0 + l_0 \alpha \theta$$

$$l = l_0 (1 + \alpha \theta)$$

**Example 5.1**

A copper rod of length 2 m, has its temperature changed from 15 °C to 25 °C. Find the change in length given that its coefficient of linear expansion

$$\alpha = 1.7 \times 10^{-5} \text{ K}^{-1}.$$

**Solution**

$$\theta = (25 - 15) \text{ }^\circ\text{C} = 10 \text{ }^\circ\text{C}$$

$$\begin{aligned} l &= l_0 \alpha \theta = 2 \times 1.7 \times 10^{-5} \times 10 \\ &= 3.4 \times 10^{-4} \text{ m} \\ &= 0.34 \text{ mm} \end{aligned}$$

**5.3.1.2 Area and volume expansion****(a) Demonstrations of area and volume expansions****Activity 5.16**

**To demonstrate volume and surface expansion and contraction using the ball and ring apparatus**

**Materials:**

- A ball and a ring
- Bunsen burner
- A bowl of cold water

**Steps**

1. Move the ball in and out of the metal ring at room temperature (see Fig. 5.24). What do you observe?
2. Keep the metal ball away from the ring and heat it for sometime.
3. Try to pass the ball through the ring. What do you observe this time? Explain.
4. Cool the metal ball in a bowl of cold water and try to pass the ball through the ring again. What do you observe now? Explain the observation.

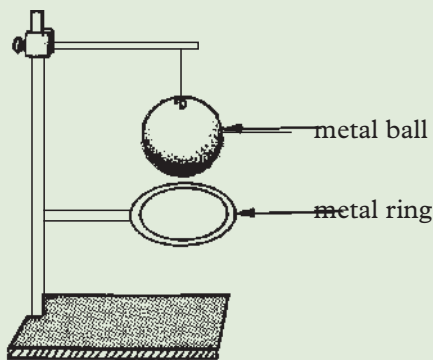


Fig. 5.24: Ball and ring apparatus

A *ball and ring* apparatus consists of a ball and ring both made of the same metal. At a room temperature, the ball and the metal ring have approximately the same diameter, thus the ball just passes through the ring. On heating, the metal ball expands. There is an increase in volume and surface area of the ball. As a result, the ball cannot pass through the ring. On cooling, contraction occurs and the original volume is regained. The ball can now pass through the ring again. This activity shows volume and surface area expansion and contraction in solids. Most solids expand on heating and contract on cooling.

### Why solids expand on heating?

In Senior I, we learnt that molecules of a solid are closely packed and are continuously *vibrating* about their fixed positions. When a solid is heated, the molecules vibrate with larger amplitude about the fixed position. This makes them to *collide* with each other with larger forces which pushes them far apart. The distance between the molecules increases and so the solid expands. The reverse happens during cooling.

### (b) Coefficients of area expansion of solids

Consider a solid whose surface area is  $A_0$ .

When the surface of the solid is heated or cooled to a temperature change of  $\theta$ , its surface area increases or decreases by  $A$  to a new value  $A$ .

Experiments have proved that the ratio of the change in surface area to original area i.e.  $\frac{A}{A_0}$  is directly proportional to the change in temperature ( $\theta$ )

$$\frac{A}{A_0} \propto \theta \Rightarrow \frac{A}{A_0} = \beta \theta \quad (\beta \text{ is a constant called coefficient of area expansivity})$$

$$\text{Hence } \beta = \frac{A}{A_0 \Delta \theta} \quad \text{Or } \beta = \frac{A - A_0}{A_0 \theta} \quad (\text{since } A = A - A_0)$$

$$\Rightarrow A - A_0 = A_0 \beta \theta$$

$$A = A_0 + A_0 \beta \theta$$

$$\therefore A = A_0(1 + \beta \theta)$$

Note:

Coefficient of area expansivity =  $2 \times$  coefficient of linear expansivity

$$\beta = 2\alpha$$

### Example 5.2

A round hole of diameter 4.000 cm at  $0^\circ\text{C}$  is cut in a sheet of brass (coefficient of linear expansion is  $0.0000017(\text{C}^\circ)^{-1}$ ). Find the new diameter of the hole at  $40^\circ\text{C}$ .

**Solution**

$$A = \beta A_0 (\theta_2 - \theta_1)$$

Given:  $\alpha = 0.00017/\text{K}$ ,  $(\theta_2 - \theta_1) = 40^\circ\text{C}$ ,  $D = 4.000 \text{ cm}$  so  $r = 2.000 \text{ cm}$ ,  $\beta = 2\alpha$  then

$$\begin{aligned} \text{Area } (A_0) &= \pi r^2 = \left(\frac{22}{7} \times 2.000 \times 2.000\right) \text{ cm}^2 \\ &= 12.571 \text{ cm}^2 \end{aligned}$$

$$\begin{aligned} \text{New area } A &= A_0 + \Delta A = (12.571 + 0.017) \text{ cm}^2 \\ &= 12.588 \text{ cm}^2 \end{aligned}$$

$$\begin{aligned} \text{Since } A &= \pi r^2, \quad \text{the new radius } r = \sqrt{\frac{A}{\pi}} = \sqrt{\frac{12.587}{3.141}} \\ &= 2.002 \text{ cm} \end{aligned}$$

**(c) Coefficients of volume expansion in solids**

When a solid is heated or cooled to a temperature change of  $\theta$ , its volume increases or decreases by  $\Delta V$  to a new value  $V$ .

The ratio of the change in volume to original volume i.e.  $\frac{\Delta V}{V_0}$  is directly proportional to the change in temperature ( $\theta$ )

$$\frac{\Delta V}{V_0} \propto \theta \Rightarrow \frac{\Delta V}{V_0} = \gamma \theta \quad (\gamma \text{ is a constant called coefficient of volume expansivity})$$

$$\text{Hence } \gamma = \frac{\Delta V}{V_0 \Delta \theta} \quad \text{Or} \quad \gamma = \frac{V - V_0}{V_0 \theta} \quad (\text{since } \Delta V = V - V_0)$$

$$\Rightarrow V - V_0 = V_0 \gamma \theta$$

$$V = V_0 + V_0 \gamma \theta$$

$$\therefore V = V_0(1 + \gamma \theta)$$

Note:

Coefficient of volume expansivity = 3  $\times$  coefficient of linear expansivity

$$\gamma = 3\alpha$$

**Example 5.3**

A metal vessel has a volume of  $800.00 \text{ cm}^3$  at  $0^\circ\text{C}$ . If its coefficient of linear expansion is  $0.000014/\text{K}$ , what is its volume at  $60^\circ\text{C}$ ?

**Solution**

Given:  $V_0 = 800.00 \text{ cm}^3$ ,  $(\theta_2 - \theta_1) = 60^\circ\text{C}$  and  $\alpha = 0.000014/\text{K} = 0.000014/^\circ\text{C}$

$$\begin{aligned}\text{Change in volume, } (\Delta V) &= 3 \alpha V_0 \Delta \theta \\ &= 3(0.000014/^{\circ}\text{C}) \times 800.00 \text{ cm}^3 \times 60^{\circ}\text{C} \\ &= 2.016 \text{ cm}^3\end{aligned}$$

$$\begin{aligned}\text{New volume (at } 60^{\circ}\text{C)} &= V_0 + \Delta V \\ &= (800.00 + 2.016) \text{ cm}^3 \\ &= 802.016 \text{ cm}^3\end{aligned}$$

### Exercise 5.2

1. What do you understand by the phrase '*coefficient of linear expansion*'?
2. A vertical steel antenna tower is 400 m high. Calculate the change in height of the tower hence its new height that takes place when the temperature changes from  $-15^{\circ}\text{C}$  on winter day to  $35^{\circ}\text{C}$  on a summer day.  
(Take  $\alpha = 0.00000645/\text{K}$ )
3. A 8 m long rod is heated to  $50^{\circ}\text{C}$ . If the rod expands to 10 m after some time, calculate its coefficient of linear expansion given that the room temperature is  $32^{\circ}\text{C}$ .
4. A rectangular solid of Brass has a coefficient of volume expansion of  $56 \times 10^{-6}/^{\circ}\text{C}$ . The dimensions of the rectangle are 5 cm  $\times$  6 cm  $\times$  8 cm at  $10^{\circ}\text{C}$ . What is the change in volume and the new volume if the temperature increases to  $90^{\circ}\text{C}$ ?
5. A solid plate of lead of linear expansion  $29 \times 10^{-6}/^{\circ}\text{C}$  is 8 cm  $\times$  12 cm at  $15^{\circ}\text{C}$ . What is the change in area and the new area of the lead if the temperature increases to  $95^{\circ}\text{C}$ ?
6. A cup made of pyrex glass has a volume of  $200 \text{ cm}^3$  at  $0^{\circ}\text{C}$ . If the coefficient of linear expansion is  $0.000003/\text{K}$ , what will be its volume if it holds hot water at  $92^{\circ}\text{C}$ .

### 5.3.2 Thermal expansion and contraction in liquids

Like solids, liquids expand on heating i.e volume increases and contract i.e Volume reduces on cooling. But liquids expand more than solids since they have relatively weak intermolecular forces. Activity 5.17 will help us to understand expansion and contraction in liquids.

**Activity 5.17****To demonstrate expansion and contraction in liquids****Materials:**

- A glass flask
- Coloured water
- Tripod stand
- A rubber stopper
- Bunsen burner
- Wire gauze
- Long glass tubing

**Steps**

1. Fill a glass flask with coloured water.
2. Fit the flask with a rubber stopper carrying a long narrow glass tubing.
3. Note the initial level of water in the glass tube before heating (Fig. 5.25).

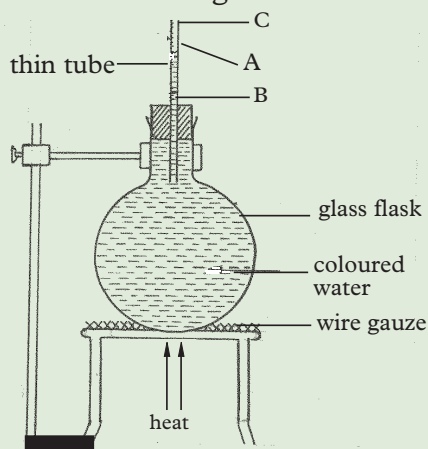


Fig. 5.25: Expansion of liquid

4. Heat the water in the flask. Observe what happens to the level of water at A immediately the heating starts and after a few minutes. Explain your observation.

In a similar activity, it was observed that at first the level of the coloured water in the tube drops to level B and then rises to level C.

On heating, the glass flask is heated first and expands i.e its volume increases. The level of water immediately drops from A to B. On continuous heating, water starts to expand hence water level rises up the tube from B to C.

If the setup is allowed to cool below room temperature, the water level drops to a point lower than A and B.

This shows that liquids expand on heating and contract on cooling.

**Why liquids expand on heating?**

Molecules are loosely packed in liquids. The force of attraction between the

molecules is weaker than in solids. The molecules move freely in the liquid. On heating, the speed of the molecules increases. The collisions between the molecules increases the distance between them causing the liquid to expand.

### 5.3.3 Thermal expansion and contraction in gases

Just like solids and liquids, gases expand on heating and contract on cooling. Gases expand more than liquids and solid because their molecules move furthest on heating. The following activity will help us to study expansion and contraction in gasses.

#### Activity 5.18

#### To demonstrate expansion of gases

##### Materials:

- A thin glass flask
- A long narrow glass tube
- A rubber stopper

##### Steps

1. Take a thin glass flask with an open top.
2. Close the flask with a rubber stopper carrying a long narrow glass tube.
3. Invert the flask so that the glass tube dips into water in a container. What do you observe? (Fig. 5.26).

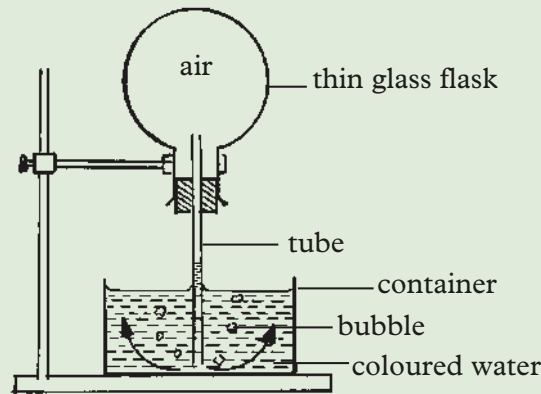


Fig. 5.26: Expansion of air

4. Place your hands over the flask to warm it for sometime and observe what happens. Explain your observation.
5. Remove your hands from the flask and wait for some time. Observe what happens. Explain your observation.

When the flask is warmed by the warmth of the hands, the level of water in the tube drops and some bubbles are formed due to air escaping from the flask through the tube.



On removing the hands from the flask, water level rises up the glass tube again due to contraction of air i.e volume of air reduces on cooling. This shows that gases expand on heating and contract on cooling..

The volume of air increases in the flask due to expansion.

### Why a gas expands on heating?

The force of attraction between the molecules of a gas is very small (almost negligible) and the distance between the molecules is large compared to solids and liquids. The molecules move freely in all directions. When a gas is warmed, the molecules gain more energy and move far apart hence volume increases.

Different gases expand by the same amount when heated equally. Activity 5.19 will demonstrate further the expansion and contraction of gases.

#### Activity 5.19

To compare rates of expansion and contraction in different gases.

#### Materials:

- A glass bulb B with air
- A metre rule in vertical position
- Steam
- Glass jacket
- A reservoir R with mercury

#### Steps

1. Set up the apparatus as shown in Fig. 5.27.

The apparatus consists of a glass bulb B containing mercury. Bulb B is surrounded by the outer glass jacket through which steam can be passed.

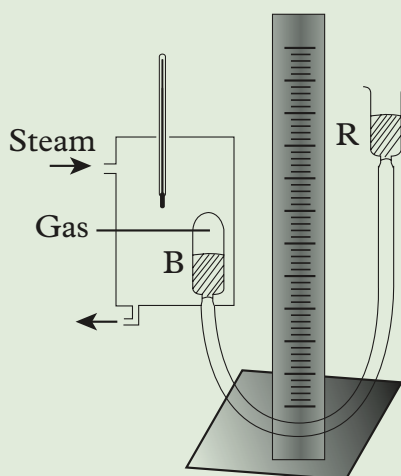


Fig. 5.27: Expansion of gas

2. Circulate water at  $0^{\circ}\text{C}$  through the jacket and adjust reservoir R so that the level of mercury in B and R is the same.
3. Measure the volume of air (gas) in bulb B.
4. Pass the steam through the jacket until the temperature is constant.
5. Adjust the level of mercury in B and R until they are the same. Measure the volume of air in B.
6. Repeat the experiment with different gases. Observe what happens. Compare the volume of air in B for the different gases. Explain the differences if any.

On passing cold water at  $0^{\circ}\text{C}$  through the glass jacket, the volume of the air in bulb B reduces due to contraction of air.

The volume of air increases on passing the steam through the glass jacket due to expansion of air.

Gases contract on cooling and expand on heating.

### 5.3.4 Applications of thermal expansion and contraction

#### Activity 5.20

To find out the applications of expansion and contraction

#### Materials

- Internet enabled devices (lab computers or tablets)
- Reference books

#### Steps

1. You have now learnt about expansion and contraction. Suggest any three applications of expansion and contraction in our daily lives.
2. Carry out a research from the internet on the applications of expansion and contraction.
3. Report your findings to the whole class.

Thermal expansion and contraction, on one hand is a nuisance and on the other hand is quite useful. The following are some of the applications of thermal expansion and contraction.

#### 1. Electric thermostats

A *thermostat* is a device made from a bimetallic strip that is used to maintain a steady temperature in electrical appliances such as electric iron boxes, refrigerators,

electric geysers, incubators, fire alarms and the automatic flashing unit for indicator lamps of motor cars. Fig. 5.28 show two such devices.

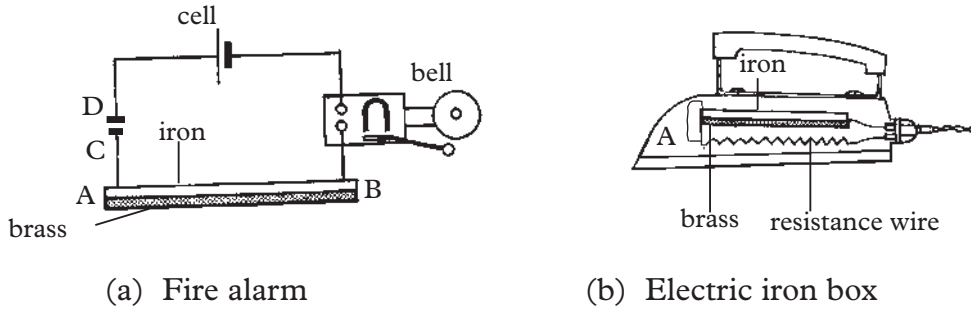


Fig. 5.28: Electric appliances with thermostat

The bimetallic, as discussed earlier, bends on expansion and relaxes on cooling, connectin and disconnecting the circuit to regulate temperature.

**Be responsible and take care!**

Conserve energy by switching off the socket after using electrical appliances. Be careful when using electrical devices to avoid electric shocks.

## 2. Making of ordinary and pyrex glasses

You may have observed that when boiling water is poured into a thick-walled glass tumbler it may break suddenly. This is because the inside of glass gets heated and expands even before the outside layer becomes warm. This causes an unequal expansion between the inside and the outside surfaces. The force produced by the expanding molecules on the inside produces a large strain in the glass and the tumbler breaks. This is the reason why pyrex glass tumblers are recommended for use while taking hot liquids.

## 3. Rivets

In industries, steel plates are joined together by means of *rivets*. Hot rivets are placed in the rivet holes and the ends hammered flat. On cooling the force of contraction pulls the plates firmly together (Fig. 5.29).

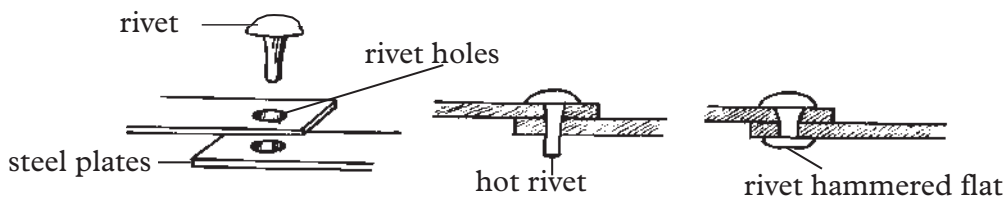


Fig. 5.29: Rivets

#### 4. Expansion joint loops

Metal pipes carrying steam and hot water are fitted with *expansion joint* or loops. These allow the pipes to expand or contract easily when steam or hot water passes through them or when the pipes cool down. The shape of the loop changes slightly allowing necessary movement of the pipes to take place (Fig. 5.30).

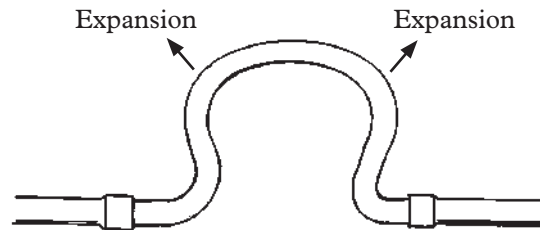


Fig. 5.30: Expansion joint

#### 5. Loosely fitted electric cables

Telephone and electricity cables are loosely fitted between the poles to allow room for contraction in cold weather and expansion in hot weather.

#### 6. Use of alloys

The *measuring tape* used by surveyors for measuring land is made of an alloy of iron and nickel called *invar*. Invar has a very small change in length when temperature changes.

#### 7. Gaps in railway tracks

*Gaps are left between the rails* when the railway tracks are laid. The rails are joined together by *fish-plates* bolted to the rails. The oval shaped bolt holes allow the expansion and contraction of the rails when the temperature changes (Fig. 5.31).

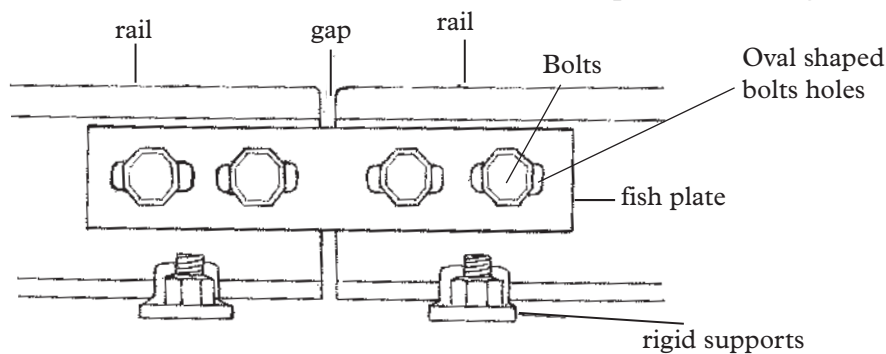


Fig. 5.31: Gaps left between rails

In very hot weather, the gaps may not be enough if the expansion is large. The rails may *buckle* out. Modern methods use long welded lines rigidly fixed to the beds of the track so that the rails cannot expand. Expansion for the rails is provided by overlapping the plane ends (Fig. 5.32).



Fig. 5.32: Overlapping joints

## 8. Rollers on bridges

The ends of steel and concrete bridges are supported on rollers. During hot or cold weather, the change in length may take place freely without damaging the structure (See Fig. 5.33).

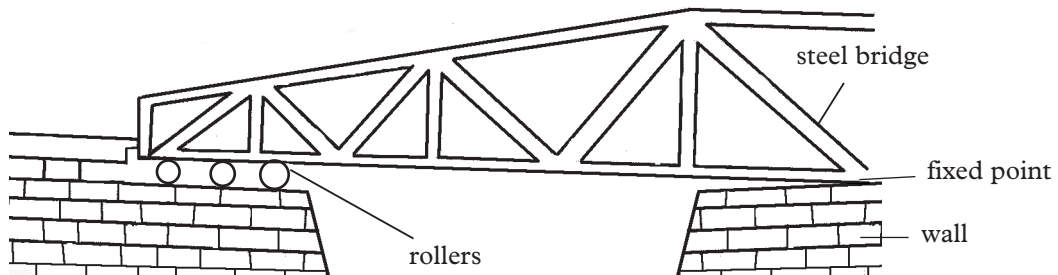


Fig. 5.33: Steel and concrete bridges are supported on rollers

## 9. Breakages.

### Activity 5.21

To demonstrate causes of expansion and contraction

#### Materials:

- A beaker
- An immersion heater
- A thermometer
- Water
- A measuring cylinder
- Stop watch

#### Steps

1. Take 200 g of water in a beaker and note its initial temperature  $\theta_1$ .

- Heat the water with an immersion heater for 10 minutes (Fig. 5.34 (a)). Note the final temperature  $\theta_2$  and calculate the change in temperature,  $\Delta\theta = \theta_2 - \theta_1$ .
- Repeat (2) above by taking 400 g of water in the same beaker and same initial temperature  $\theta_1$  (Fig. 5.34 (b)). Note the time taken to produce the same change in temperature as before.
- Compare the times taken to produce the same change in temperature in 200g and 400g of water. What is your conclusion?

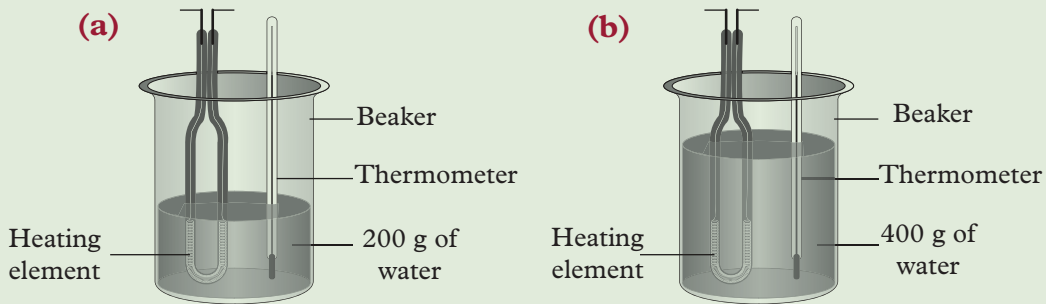


Fig. 5.34: Relationship between heat energy and mass of the substance.

Sudden expansion and contraction can lead to breakages of things like glasses and egg shells. This behaviour is mitigated against in the manufacture of glass items such as the drinking glass. They are made of thin walls to allow even expansion and contraction thus minimising chances of breakage.

### Exercise 5.3

- Use particles model to explain thermal expansion of solids.
- Explain why:
  - Steel bridges are usually supported by rollers on one loose side.
  - Metal pipes carrying steam and hot water are fitted with loops.
- Describe how shrink fitting is done.
- State two applications of contraction of solids.
- Name three physical properties that change when heating a solid.

## 5.4 Quantity of heat

As we have already learnt, heat is a form of energy that flow from a region of high temperature to a region of lower temperature. Cold substances absorb heat energy while hot ones lose heat energy. This section deals with measures of the capacities of substances to gain or loose heat energy.

### 5.4.1 Heat capacity

#### Activity 5.22

To show that the heat energy required to produce a certain change in temperature depends on the mass of the substance.

#### Materials

- Water bath
- Heat source
- An egg

#### Steps

1. Place an egg in a water bath. Heat the water bath till the water boils.
2. Transfer the egg to a beaker of cold water and observe. Explain what happens to the egg?

The larger the mass, the longer the time needed to change its temperature. This means the larger the mass, the more heat is supplied to change the temperature by one degree. Hence the quantity of heat energy,  $Q$ , gained by a substance through a certain temperature change is directly proportional to its mass,  $m$ . Therefore, Heat energy is proportional to mass that is;

$$Q \propto m, \text{ when temperature change is constant.}$$

#### Activity 5.23

To show that the heat energy required by a substance of a given mass depends on the change in temperature

#### Steps

1. Repeat activity 5.22 step 2 with 200 g of water, but this time, heat to produce twice the change in temperature. Note the time taken for this to happen.
2. Which case takes more time, heating up to a given temperature or up to double that temperature?
3. What relationship does this observation show between quantity of heat and change in temperature?

The longer the time of heating, the more heat energy supplied and the greater the temperature change.

Heat energy,  $Q$  is proportional to change of temperature,  $\Delta\theta$ , when mass of a substance is constant.  $Q \propto \Delta\theta$ .

#### Example 5.4

200 J of heat energy is needed to change the temperature of a given mass of water from 20 °C to 34 °C. How much heat energy is needed to change the temperature of this mass of water from 20 °C to 48 °C.

**Solution**

Case 1: temperature change =  $(34 - 20) = 14\text{ }^\circ\text{C}$ , heat required  $Q_1 = 200\text{ J}$

Case 2: temperature change =  $(48 - 20)^\circ\text{C} = 28\text{ }^\circ\text{C}$

$$200\text{ J} \text{ ————— } 14\text{ }^\circ\text{C}$$

$$Q_2 \text{ ————— } 28\text{ }^\circ\text{C}$$

$$\begin{aligned} \text{Heat energy needed, } Q_2 &= \frac{200 \times 28}{14} \\ &= 400\text{ J} \end{aligned}$$

Heat capacity of a substance can be therefore defined as **the heat energy required to raise the temperature of a substance by 1 K.**

Mathematically,

$$\text{Heat capacity (c)} = \frac{\text{Amount of Heat supplied (Q)}}{\text{Temperature change } (\Delta\theta)} \text{ J/K}$$

The SI unit of heat capacity is joule per kelvin (J/K)

**Example 5.5**

Calculate the quantity of heat required to raise the temperature of a metal block of capacity of 520 J/K from  $9\text{ }^\circ\text{C}$  to  $39\text{ }^\circ\text{C}$ .

**Solution**

Quantity of heat  $Q = \text{Heat capacity} \times \text{temperature change}$

$$\begin{aligned} Q &= c \times \Delta\theta \\ &= 520 \times (39 - 9) \\ &= 15\,600\text{ J} \end{aligned}$$

**Example 5.6**

The quantity of heat required to raise the temperature of water from  $10\text{ }^\circ\text{C}$  to  $65\text{ }^\circ\text{C}$  is 6 200 J. Calculate the heat capacity of water.

**Solution**

$$\begin{aligned} Q = c\Delta\theta \Rightarrow C &= \frac{Q}{\Delta\theta} \\ &= \frac{6\,200\text{ J}}{(65 - 10)\text{K}} = 112.73\text{ J/K} \end{aligned}$$

The heat capacity of water is 112.73 J/K



**Exercise 5.4**

1. The heat capacity of water depends on the mass of the water being heated. TRUE or FALSE? Justify your answer.
2. Calculate the heat capacity of tea when 400 J of heat are supplied to change its temperature from 25 K to 40 K.
3. Calculate the amount of heat energy given out to lower the temperature of a metal block of heat capacity 520 J/K from 60 °C to 20 °C.

**5.4.2 Specific heat capacity**

From activities 5.22 and 5.23 we learnt that.

Quantity of heat,  $Q \propto$  mass,  $m$

$Q \propto$  change in temperature,  $\Delta\theta$

$Q \propto m\Delta\theta$  or

$Q = mc\Delta\theta$  where  $c$  is a constant

When the mass of the substance is 1 kg (i.e.  $m = 1$  kg) and the change in temperature is 1K (i.e.  $\Delta\theta = 1$  K), then  $Q = c$  and  $c$  is referred to as the *specific heat capacity* of the substance.

The specific heat capacity,  $c$  of a substance is defined as the **heat energy required to change the temperature of a substance of mass 1 kg by 1 Kelvin.**

$$c = \frac{Q}{m\Delta\theta}$$

Therefore,

Quantity of heat = mass  $\times$  specific heat capacity  $\times$  temperature change

$$Q = mc\Delta\theta$$

where,  $\Delta\theta =$  final temperature – initial temperature

*The SI unit of specific heat capacity is joule per kilogram per Kelvin (J/kg K).*

**Example 5.7**

Calculate the heat energy required to raise the temperature of 2.5 kg of aluminium from 20 °C to 40 °C, if the specific heat capacity of aluminium is 900 J/kg K.

**Solution**

Heat energy required = mass  $\times$  specific heat capacity  $\times$  temperature change

$$\begin{aligned} Q &= mc\Delta\theta \\ &= 2.5 \times 900 \times (40 - 20) \\ &= 45\,000 \text{ J} \end{aligned}$$

**Example 5.8**

18 000 J of heat energy is supplied to raise the temperature of a solid of mass 5 kg from 10 °C to 50 °C. Calculate the specific heat capacity of the solid.

**Solution**

$$\begin{aligned} c &= \frac{Q}{m\Delta\theta} \\ &= \frac{180\,000 \text{ J}}{(50 - 10)\text{K} \times 5 \text{ kg}} \\ &= 900 \text{ J/kg K} \end{aligned}$$

**Example 5.9**

Find the final temperature of water if 12 000 J of heat is supplied by a heater to heat 100 g of water at 10 °C.

(Take specific heat capacity of water and 4 200 J/kg K)

**Solution**

$$\begin{aligned} Q &= mc\Delta\theta \Rightarrow \Delta\theta = \frac{Q}{m \times c} \\ &= \frac{12\,000 \text{ J}}{(0.1 \times 4\,200) \text{ J/K}} \\ &= \frac{12\,000 \text{ J}}{420} \\ &= 28.57^\circ\text{C} \end{aligned}$$

$\Delta\theta = \theta_f - \theta_i$ , where  $\theta_f$  – final temperature,  $\theta_i$  – initial temperature

$$\Rightarrow \theta_f = \Delta\theta + \theta_i = 28.57^\circ\text{C} + 10^\circ\text{C}$$

$$\theta_f = 38.57^\circ\text{C}$$

The final temperature is 38.57 °C.

### Exercise 5.5

1. 45 000 J of heat are supplied to 5 Kg of aluminium initially at 25°C. What is its final temperature? (Take the specific heat capacity of aluminium as 900 J/kgk).
2. What is the difference between heat capacity and specific heat capacity?
3. 24 000 J of heat energy is supplied to raise the temperature of a substance of mass 6 kg from 12 °C to 48 °C. Calculate the specific heat capacity of the substance.

### Comparison of specific heat capacities of the three states of matter

#### Activity 5.24

To show that different substances have different specific heat capacity

#### Materials

- Two thermometers
- A lid with two holes
- Two boiling tubes (one containing cooking oil and the other water)
- A hot water bath

#### Steps

1. Pour equal volume of liquids (cooking oil and water) into two identical test tubes. Place identical thermometers in each test tube (Fig. 5.35).

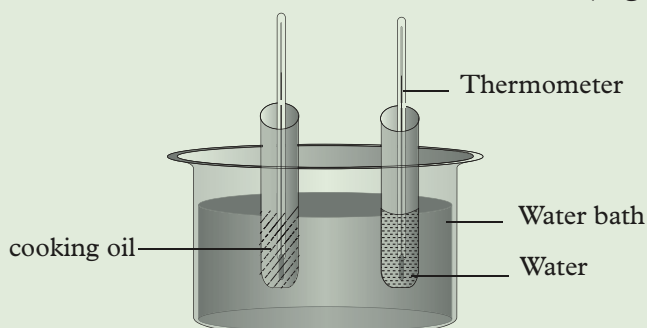


Fig. 5.35: Set-up to show different specific heat capacities

2. Heat the test tubes in a hot water bath for the same time. Observe and compare the temperature changes in the two cases. Explain the difference if any.

Different substances have different specific heat capacities. Solids require more heat energy to melt than liquids and gases. This means that solids have higher

specific heat capacity than liquids and gases. Gases have the lowest specific heat capacity.

Two different substances of the same mass when subjected to the same quantity of heat, acquire different changes in temperature. Table 5.1 shows that different substances have different specific heat capacities. This is true for solids and liquids but not in gases

Table 5.1: Values of specific heat capacities of metals

Substance	Specific heat capacity (c) J/kg K
Aluminium	900
Brass	370
Copper	390
Cork	2000
Glass	670
Ice	2100
Iron	460
Lead	130
Silver and tin	230

### Activity 5.25

### To determine the specific heat capacity of a solid by the electrical method

#### Materials

- Electric circuit
- Metal cylinder
- Variable resistor
- Aluminum foil
- Solid metal blocks in the form of a cylinder, with 2 holes.
- Heating element
- Thermometer
- Cotton wool
- Wooden container

#### Steps

1. Measure and record the mass,  $m$ , of the metal cylinder.
2. Insert an electrical heater in position in the metal block through the larger hole and a thermometer through the other hole.
3. Note the initial temperature of the metal block  $\theta_1$ .
4. Cover the solid with cotton wool or felt material and wrap a aluminium foil around cotton wool.
5. Place the set up a wooden container. Complete the electrical circuit as shown in Fig. 5.36.

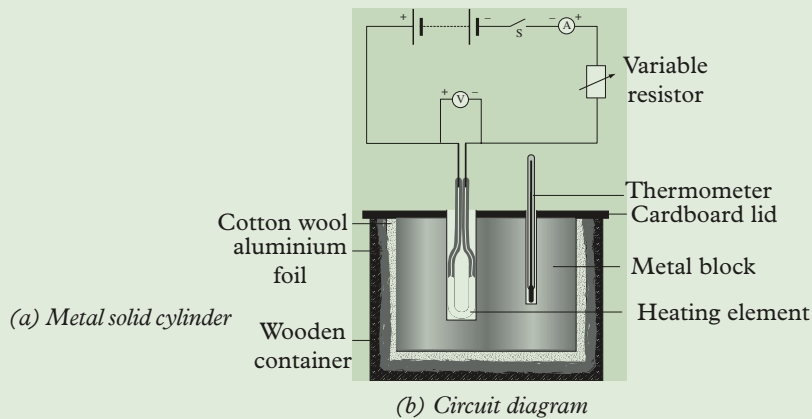


Fig. 5.36: Specific heat capacity of a solid by electrical method.

6. Close the switch S and start a stop watch at the same time.
7. Use the variable resistor to maintain a steady current passing through the heater.
8. Note the current  $I$  through the heater with the ammeter and the potential difference,  $V$  across the heater with the voltmeter.
9. Pass this steady current for some time so that the rise in temperature in the solid is about  $8^\circ\text{C}$ .
10. Note the time  $t$ , when the final temperature of the solid is  $\theta_2$ .
11. Calculate the change in temperature  $\Delta\theta = \theta_2 - \theta_1$ .
12. Show the relationship between electrical energy used and the heat energy gained by the metal and hence calculate the specific heat capacity of the metal cylinder.
13. How much electrical energy has been spent in this time? What has happened to this energy? What is the purpose of cotton wool or felt material, aluminium foil and the wooden container?

Electrical energy  $E$ , spent by the heater in a time,  $t$ , is given by  $E = VIt$ . This energy is converted into heat energy and has been absorbed by the metal solid cylinder. Heat energy gained by the metal

$$Q = mc\Delta\theta$$

Assuming no energy from the heater is lost to the surrounding,  
 electrical energy used = heat energy gained by the metal cylinder.

$$\therefore VIt = mc\Delta\theta$$

from which the specific heat capacity,  $c$ , of the solid can be calculated.

$$\therefore c = \frac{VIt}{m\Delta\theta}$$

**Example 5.10**

The following data was obtained from an experiment similar to that of Activity 5.25. Mass of copper metal block = 200 g, initial temperature of the block = 22°C, ammeter reading = 0.5 A, voltmeter reading = 3.0 V, final temperature of the block = 30 °C, time of heating = 7 minutes. Use the data to calculate the specific heat capacity of copper. What does this value mean?

**Solution**

Electrical energy spent is given by,  $E = VIt$ .

Assuming no energy from the heater is lost to the surrounding,

Heat energy gained by the metal block =  $mc\Delta\theta$ .

$$mc\Delta\theta = VIt$$

$$\begin{aligned}\therefore c &= \frac{VIt}{m\Delta\theta} = \frac{3.0 \times 0.5 \times (7 \times 60)}{0.200 \times (30 - 22)} \\ &= \frac{3.0 \times 0.5 \times 420}{0.200 \times 8} \\ &= 393.75 \text{ J/kg K}\end{aligned}$$

$\therefore$  specific heat capacity of copper = 394 J/kg K

This means that to raise the temperature of 1 kg of copper by 1 K (or by 1°C), 394 Joules of heat energy are required.

**Example 5.11**

Calculate the heat energy required to raise the temperature of 2.5 kg of aluminium from 20 °C to 40 °C, if the specific heat capacity of aluminium is 900 J/kg K.

**Solution**

Heat energy required  $Q = mc\Delta\theta$

$$\begin{aligned}&= 2.5 \times 900 \times (40 - 20) \text{ J} \\ &= 45\,000 \text{ J}\end{aligned}$$

**Activity 5.26**

**To determine the specific heat capacity of water by the method of mixtures**

**Materials**

- A solid of known specific heat capacity ( $c_s$ )
- Weighing machine
- Thermometer
- Stirrer
- Tripod stand
- Water bath
- Beaker
- Heating source

**Steps**

1. Take a solid of known specific heat capacity ( $c_s$ ) and measure its mass ( $m_s$ ).
2. Heat it in a water bath till the water starts boiling, as shown in Fig. 5.37 (a).
3. In the meantime, take an empty, clean and dry container of known specific heat capacity ( $c_c$ ) and measure its mass ( $m_c$ ).
4. Put water into the container, say to half of the container, and measure the total mass.
5. Calculate the mass of water ( $m_w$ ) whose specific heat capacity ( $c_w$ ) is to be determined.
6. Find the initial temperature ( $\theta_1$ ) of water and the container (Fig. 5.37 (b)).
7. When water in the water bath has started boiling, note the temperature of the solid ( $\theta_s$ ) in the water bath.
8. Quickly transfer the hot solid into cold water in the container and observe the temperature of the mixture.

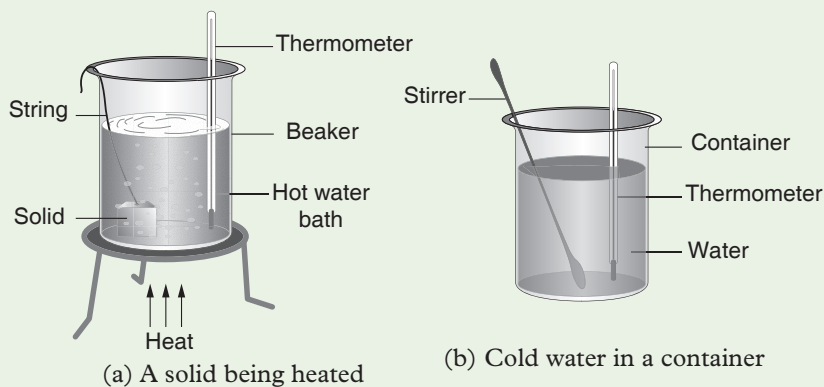


Fig. 5.37: Specific heat capacity of water by method of mixture.

9. Stir the contents gently to distribute the heat uniformly throughout the mixture and note the final maximum steady temperature of the mixture ( $\theta_2$ ).
10. What happens to the cold water and the container when the hot solid is transferred into the container?
11. Using all the data you have collected, calculate the specific heat capacity of water using the equation:
 
$$\text{Heat lost by solid} = \text{heat gained by water}$$
12. What precautions have to be taken to ensure accuracy in the experimental procedure?
13. Highlight the assumptions for this activity.

The temperature of the solid has decreased from  $\theta_s$  to  $\theta_2$ , showing that the solid has lost heat energy. The temperature of the cold water and the container has

increased from  $\theta_1$  to  $\theta_2$  showing that they have gained heat energy.

$$\text{Quantity of heat energy lost by the hot solid} = m_s c_s (\theta_s - \theta_2)$$

Quantity of heat energy gained by the container and cold water

$$= (m_c c_c + m_w c_w) (\theta_2 - \theta_1)$$

Assuming no energy is lost to the outside;

Energy lost by the hot solid = heat energy gained by the container and cold water.

$$\therefore m_s c_s (\theta_s - \theta_2) = (m_c c_c + m_w c_w) (\theta_2 - \theta_1)$$

from which the specific heat capacity of water ( $c_w$ ) can be calculated.

As a precaution, the container has to be covered with wool or felt and aluminium foil wrapped round the cotton wool. Note; the whole arrangement has to be placed inside a wooden container before the hot solid is transferred into the cold water in the container. These precautions ensure that minimum heat energy is lost from the mixture to the surroundings.

Experiments show that specific heat capacity of water is 4 200 J/kgK. This means that we need 4 200 Joules of heat energy to raise the temperature of 1 kg of water by 1K. Note that this value is about 10 times more than that of copper or iron. Once water is heated it retains the heat energy for a long time due to its high specific heat capacity.

### Example 5.12

In an experiment, to calculate the specific heat capacity of water, the following data was obtained. Mass of the solid = 50 g, specific heat capacity of the solid = 400 J/kg K, initial temperature of the hot solid = 100 °C, mass of the container = 200 g, specific heat capacity of the material of the container = 400 J/kg K, mass of water = 100 g, initial temperature of the water and the container = 22 °C.

When the hot solid was transferred into the cold water in the container, the temperature of the mixture was 25 °C.

Use the data to calculate the specific heat capacity of water.

### Solution

Let the specific heat capacity of water be  $c_w$

$$\begin{aligned} \text{Heat lost by the hot solid} &= mc\Delta\theta = 0.050 \times 400 \times (100 - 25) \\ &= 1\,500 \text{ J} \end{aligned}$$

$$\begin{aligned} \text{Heat gained by the container and water} &= mc\Delta\theta_{\text{container}} + mc\Delta\theta_{\text{water}} \\ &= 0.200 \times 400 \times (25 - 22) + 0.100 \times c_w (25 - 22) \text{ J} \\ &= 80 \times 3 + 0.1 c_w \times 3 \\ &= 3 (80 + 0.1 c_w) \text{ J} \end{aligned}$$



Assuming no energy losses to the surroundings

Heat lost = heat gained

$$1\,500\text{ J} = 3(80 + 0.1 c_w)$$

$$500 = 80 + 0.1 c_w \text{ (on dividing by 3 both sides)}$$

$$420 = 0.1 c_w$$

$$\therefore c_w = 4\,200\text{ J/kg K}$$

### Activity 5.27

To determine the specific heat capacity of a liquid by electrical method

#### Materials

- Carolimeter
- Heater
- Variable resistor
- Stirrer
- A liquid
- Thermometer
- Electrical circuit

#### Steps

1. Measure and record the mass,  $m_c$ , of an empty, clean and dry copper container with the stirrer of the same specific heat capacity,  $c_c$ .
2. Gently pour the liquid of known mass,  $m_p$ , into the container. Let the specific heat capacity of the liquid be  $c_l$ .
3. Note the initial temperature of the liquid and the container,  $\theta_1$ .
4. Complete the electrical circuit as shown in Fig. 5.38 with the heater fully immersed in the liquid without touching the base or the sides of the container.

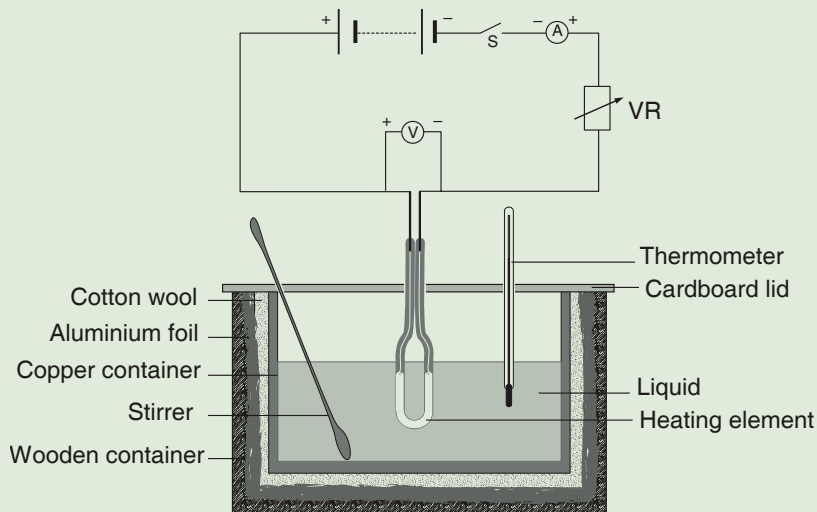


Fig. 5.38: Finding specific heat capacity of a liquid by electrical method.

5. Close the switch  $S$  and start a stop watch at the same time.
6. Use the variable resistor  $VR$  to maintain a steady current passing through the heater.
7. Note the current  $I$  through the heater with the ammeter and a p.d  $V$  across it with the voltmeter. Pass this steady current for some time so that the rise in temperature of the liquid and the container is about  $5^\circ\text{C}$ .
8. Keep stirring the liquid gently throughout the experiment. Note the time,  $t$ , taken when the final temperature of the liquid and the container is  $\theta_2$ . Calculate the change in temperature  $\Delta\theta = (\theta_2 - \theta_1)$ .
9. How much electrical energy has been spent in this time?
10. What has happened to this energy?
11. Using all the data you have collected, calculate the specific heat capacity of the liquid.  
(Hint: Electrical energy supplied = heat energy gained by liquid)
12. What precautions have to be taken during the experiment?

Electrical energy spent = heat energy gained by the liquid, the container and the stirrer.

$$\therefore VIt = m_c c_c (\theta_2 - \theta_1) + m_l c_l (\theta_2 - \theta_1)$$

$$VIt = (m_c c_c + m_l c_l) \Delta\theta$$

From this equation, the specific heat capacity of the liquid  $c_l$  can be calculated. Different liquids have different specific heat capacities. Table 5.2 shows the specific heat capacity of some liquid

Table 5.2

Substance	Specific heat capacity (c) J/kg K	Substance	Specific heat capacity (c) J/kg K
Castor oil	2 130	Olive oil	2 000
Coconut oil	2 400	Paraffin oil	2 130
Glycerol	2 400	Sulphuric acid	1 380
Mercury	140	Water	4 200

### Example 5.13

In an Activity similar to 5.27, the following data was obtained. Power of electric heater =  $30\text{ W}$ , mass of the container and the stirrer =  $200\text{ g}$ , specific heat capacity of the container and the stirrer =  $400\text{ J/kg K}$ , mass of water in the container =  $100\text{ g}$ , specific heat capacity of water =  $4\,200\text{ J/kg K}$ .

Use the data to calculate the time taken by the heater to rise the temperature of water, container and the stirrer from 20 °C to 23 °C. What assumption have you made in your calculations?

### Solution

Assuming all the electrical energy is absorbed by the container, stirrer and water,

Electrical energy used = Heat energy gained

$$VI t = (mc\Delta\theta)_{\text{container + stirrer}} + (mc\Delta\theta)_{\text{water}}$$

As electrical power  $P = VI$  and the time taken is  $t$ ,

$$Pt = (mc\Delta\theta)_{\text{container + stirrer}} + (mc\Delta\theta)_{\text{water}}$$

$$\therefore 30 t = 0.200 \times 400 \times 3 + 0.100 \times 4\,200 \times 3$$

$$30 t = 3(0.200 \times 400 + 0.100 \times 4\,200)$$

$$30 t = (80 + 420)3$$

$$\therefore t = 50 \text{ seconds}$$

The assumption made is that there is no heat used to the surrounding.

### Exercise 5.6

Where necessary, take specific heat capacity of water = 4 200 J/kg K, acceleration due to gravity  $g = 10 \text{ m/s}^2$ .

- Define (a) heat capacity (b) specific heat capacity of a substance
- Calculate the:
  - heat energy required to raise the temperature of 200 g of gold of specific heat capacity 130 J/kg K by 1 000 °C.
  - heat energy given out when a piece of hot iron of mass 2 kg cools down from 450 °C to 25 °C, if the specific heat capacity of iron is 460 J/kg K.
- Describe an activity to determine the specific heat capacity of a solid by the method of mixtures. State the necessary precautions to be taken during the activity.
- Define specific heat capacity of water. How would you determine the specific heat capacity of water by the method of mixtures?
- An electric kettle rated 2 kW is filled with 2.0 kg of water and heated from 20 °C to 98 °C. Calculate the time taken to heat the water assuming that all the electrical energy is used to heat the water in the electric kettle and the kettle has negligible heat capacity.

6. A hot solid of mass 100 g at 100 °C is quickly transferred into 100 g of water in a container of mass 200 g at 20 °C. Calculate the resulting temperature of the mixture. Specific heat capacity of the solid and the container is 400 J/kgK.
7. An electric heater rated 1 500 W is used to heat water in an insulated container of negligible heat capacity for 10 minutes. The temperature of water rises from 20 °C to 40 °C. Calculate the mass of water heated.
8. A piece of metal of mass 200 g at a temperature of 150 °C is placed in water of mass 100 g and temperature 20 °C. The final steady temperature of the water and the piece of metal is 50 °C. Neglecting any heat losses, calculate the specific heat capacity of the metal.
9. Describe an experiment to determine the specific heat capacity of a liquid by electrical method.
10. A piece of iron of mass 200 g at 300 °C is placed in a copper container of mass 200 g containing 100 g of water at 20 °C. Find the final steady temperature of the mixture, assuming no energy losses. The specific heat capacities of copper and iron are 390 J/kg K and 460 J/ kg K. respectively.
11. A class of Physics students decided to determine the specific heat capacity of water in a waterfall. They used a sensitive thermometer to find the difference in temperature of water at the top and the bottom of the waterfall and obtained the following results; height of the waterfall = 52 m, temperature of water at the top = 21.54 °C. Temperature of water at the bottom = 21.67 °C. Stating any assumptions made, calculate a value for the specific heat capacity of water.

### 5.4.3 Latent heat and specific latent heat

#### 5.4.3.1 Latent heat of fusion

##### (a) Definition of latent heat of fusion

Heat is either absorbed or given out at a constant temperature when a substance is changing its state. When a substance changes from a solid state to a liquid state, heat is absorbed. This heat is called the **latent heat of fusion** of a substance. The *latent heat of fusion of a substance is defined as the quantity of energy required to change the substance from solid state to the liquid state without change in temperature at a constant pressure.*

When the mass of the substance undergoing change is 1 kg, the absorbed heat is called **specific latent heat of fusion**. *The specific latent heat of fusion of a substance is defined as the quantity of heat energy required to change 1 kg of the substance from solid state to the liquid state without change in temperature at a constant pressure.*

The latent heat of fusion required in the ( $Q$ ) is directly proportional to the mass of the substance i.e.

$$Q \propto m$$

$$Q = lm$$

Where  $l$  is constant called *specific latent heat of fusion* of the substance.

$$\therefore l = \frac{Q}{m}$$

SI units of specific latent heat of fusion is *Joule per kilogram (J/kg)*.

### (b) Finding specific latent heat of fusion of ice

Since pure ice melts at  $0^\circ\text{C}$  under standard atmospheric pressure, the specific latent heat of fusion of ice ( $l_{\text{ice}}$ ) is defined as *the quantity of heat energy required to change 1 kg of ice at  $0^\circ\text{C}$  to 1 kg of water at  $0^\circ\text{C}$  under standard atmospheric pressure.*

#### Activity 5.28

#### To determine the specific latent heat of fusion of ice by electrical method

##### Materials

- Pure ice
- Stand & clamp
- Filter funnel
- Electrical circuit
- Heater
- Stopwatch

##### Steps

1. Take some pure crushed ice at  $0^\circ\text{C}$  in a filter funnel which is well insulated from the outside with a cardboard lid and lagging material like felt or cotton wool as shown in Fig. 5.39. Complete the electrical circuit as described in Activity 5.27, with the electric heater completely covered by ice.
2. Close the switch. Take an empty, clean and dry beaker and find its mass  $m_1$ .
3. Place the beaker under the funnel and start a stopwatch when the first drop of water is collected.
4. Note the steady current,  $I$ , through the heater and the p.d  $V$  across it.
5. Collect enough water in the beaker and stop the stopwatch.

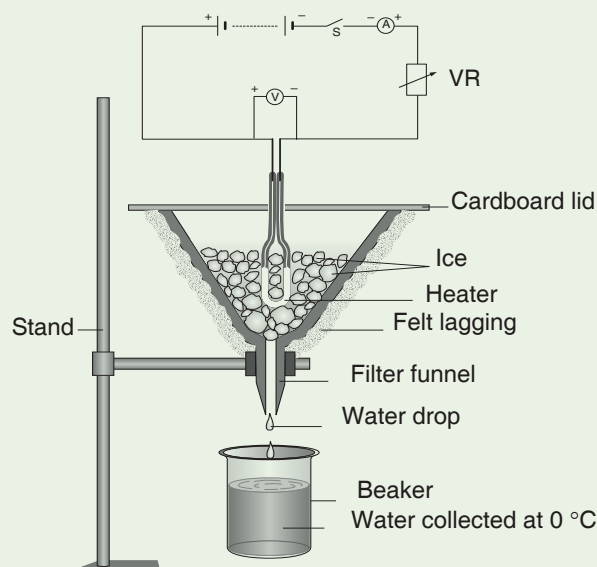


Fig. 5.39: Specific latent heat of fusion of ice

6. Note the time,  $t$ , taken to collect this water. Find the mass of the beaker with the water  $m_2$ .
7. Calculate the mass,  $m$ , of the water collected i.e. the mass of ice at  $0\text{ }^\circ\text{C}$  which has melted.  $m = (m_2 - m_1)$ .
8. Using the data you have collected, calculate the specific latent heat of fusion of ice using the equation

Electrical energy supplied = latent heat gained by ice in melting

How much electrical energy has been spent in time  $t$ ? What has happened in this energy?

Electrical energy spent =  $VIt$

Heat energy gained by ice at  $0\text{ }^\circ\text{C}$  in time  $t$  is given by  $Q = ml_{\text{ice}}$ , where  $l_{\text{ice}}$  is the specific latent heat of fusion of ice. Assuming no electric energy is lost from heater,

$$VIt = ml_{\text{ice}}$$

From which  $l_{\text{ice}}$  can be calculated.

Experiments show that the specific latent heat of fusion of ice is  $3.36 \times 10^5\text{ J/kg}$ . This means that we need 336 000 joules of energy to convert 1 kg of ice at  $0\text{ }^\circ\text{C}$  to water at  $0\text{ }^\circ\text{C}$  under standard atmospheric pressure.

**Example 5.14**

An electric heater rated 1.5 kW is used to melt 1.5 kg of ice at 0 °C. Calculate the specific latent heat of fusion of ice, if it takes 5.6 minutes for the heater to melt all the ice at 0 °C.

**Solution**

Electrical energy spent in time,  $t = VI t$

$$= Pt \text{ (since electrical power, } P = VI \text{)}$$

Heat energy gained by ice to change its state  $Q = m l_{\text{ice}}$

Assuming no energy losses,

$$Pt = m l_{\text{ice}}$$

$$l_{\text{ice}} = \frac{P \times t}{m} = \frac{1\,500 \times (5.6 \times 60)}{1.5}$$

$$= 336\,000 \text{ J/kg}$$

**Activity 5.29**

**To determine the specific latent heat of fusion of ice by the method of mixtures**

**Materials**

- Container with known specific heat capacity
- Warm water
- Ice
- Heat capacity
- Thermometer
- Weighing machine

**Steps**

1. Take an empty, clean and dry container of known specific heat capacity ( $c_c$ ) and measure its mass ( $m_c$ ).
2. Add some warm water at a temperature a few degrees above room temperature to the container and note its temperature ( $\theta_1$ ).
3. Measure the mass of the container with warm water and calculate the mass of water ( $m_w$ ).
4. Dry small pieces of ice with a blotting paper and gently immerse them into the warm water, without splashing out any water.

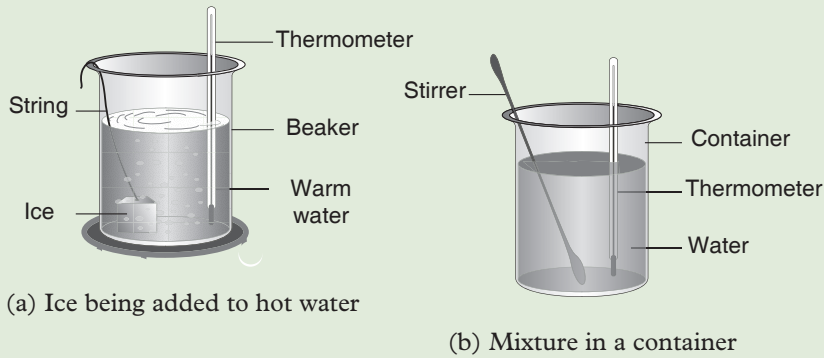


Fig. 5.40: Specific heat capacity of water by method of mixtures.

5. Keep adding the small pieces of dried ice till the temperature of the mixture is a few degrees below room temperature.
6. Note the temperature of the mixture ( $\theta_2$ ). Find the mass of the mixture.
7. Calculate the mass of ice ( $m_{ice}$ ) which has been added.
8. Using the data you have collected, determine the latent heat of fusion of ice..  
(**Hint:** Heat gained by ice to melt = heat lost by warm liquid water)

Assuming no energy losses;

heat energy given out by the container and warm water = heat energy used in melting ice at  $0^\circ\text{C}$  + heat energy used in rising the temperature of the melted ice from  $0^\circ\text{C}$  to  $\theta_2^\circ\text{C}$ .

$$\therefore m_c c_c (\theta_1 - \theta_2) + m_w c_w (\theta_1 - \theta_2) = m_{ice} l_{ice} + m_{ice} c_w (\theta_2 - 0_1)$$

where  $c_w$  is the specific heat capacity of water and  $l_{ice}$  is the specific latent heat of fusion of ice. From the above equation we can calculate  $l_{ice}$ .

### 5.4.3.2 Latent heat of vaporisation

#### (a) Definition of latent heat of vaporisation

When a liquid changes into vapour, the temperature remains constant till all the liquid has changed its state to vapour. This shows that heat is absorbed to change the state from liquid to vapour state. The heat is called the *latent heat of vaporisation* of the liquid. *The latent heat of vaporisation of a liquid is the amount of heat energy required to change the substance from the liquid state to vapour state at a constant pressure without change in temperature.*

When the mass of the substance undergoing change is 1 kg, the heat is called *specific latent heat of vaporisation*. The specific latent heat of vaporisation of a substance is *the quantity of heat energy required to change 1 kg of the substance from the liquid state to the gaseous state at a constant pressure without change in temperature.*



The quantity of heat energy required to change a liquid of mass,  $m$ , into vapour is given by,

$$Q = ml$$

where  $l$  is called the *specific latent heat of vaporisation* of the liquid

### (b) Finding specific latent heat of vaporisation of water or steam

Specific latent heat of vaporisation of water ( $l_{\text{water}}$ ) is the quantity of heat energy required to change 1 kg of water at 100 °C to 1 kg of steam at 100 °C under standard atmospheric pressure.

#### Activity 5.30

To determine the specific latent heat of vaporisation of water by electrical method.

#### Materials

- Beaker
- Insulated container
- Stopwatch
- Heater electrical circuit
- Tube T
- Stopper
- Cold water
- Thermometer

#### Steps

1. Take some water in a glass container which is well insulated from the outside with a rubber/cork stopper at the top and bottom and a lagging material like cotton wool around it.
2. Insert a long glass tube T and a condenser as shown in Fig 5.41, with the electric heater fully immersed in water.
3. Complete the electrical circuit as shown.
4. Close the switch  $S$ . Let a steady current,  $I$ , flow through the heater for sometime till water boils.
5. Adjust the variable resistor so that a steady current flows through the heater.
6. Take an empty, clear and dry beaker and find its mass,  $m_1$ .

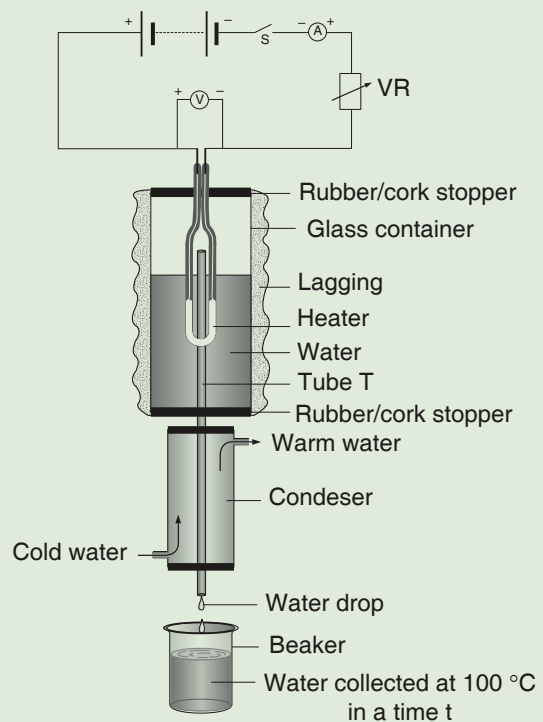


Fig. 5.41: Specific latent heat of vaporisation

7. Place the beaker under the condenser, where cold water is being circulated, and start a stopwatch when the first drop of water is collected.
8. Collect enough water in the beaker. Note the time taken,  $t$ , to collect this mass of water.
9. Find the mass of the beaker again with the water collected,  $m_2$  and calculate the mass  $m$  of water collected, i.e the mass of steam at  $100^\circ\text{C}$  which has condensed  $m = (m_2 - m_1)$ .
10. Assuming that there is no energy loss, calculate the latent heat of fusion using the data you have obtained.

How much electrical energy has been spent in this time,  $t$ ? What has happened to this energy?

$$\text{Electrical energy spent} = VIt$$

Heat energy gained by water at  $100^\circ\text{C}$  = energy used to form steam at  $100^\circ$  which condenses into water.

The heat energy is given by the equation;

$$Q = ml_w$$

Where  $l_w$  is the specific latent heat of vaporisation of water or steam.

Assuming no energy losses,

$$VIt = ml_w$$

$$\text{Hence } l_w = \frac{VIt}{m}$$

Experiments show that the specific latent heat of vaporisation of water  $l_w$  is  $2.26 \times 10^6$  J/kg. This means that  $2.26 \times 10^6$  Joules of energy are needed to convert 1 kg of water at  $100^\circ\text{C}$  to 1 kg of steam at  $100^\circ\text{C}$  under standard atmospheric pressure.

### Example 5.15

An electric kettle rated 1 500 W is used to boil 500 g of water into steam at  $100^\circ\text{C}$ . Calculate the time required to boil off the water, if the specific latent heat of vaporisation of water is 2.26 MJ/kg. Why is the correct time likely to be longer than your calculated time?

### Solution

Let the time taken to boil off water be  $t$  (s)

$$\text{Electrical energy spent} = VIt = Pt \dots (i)$$

$$\text{Heat energy required to boil off 500 g of water} = ml_{\text{water}} \dots (ii)$$

$$\text{From (i) and (ii), } ml_{\text{water}} = Pt$$

$$\begin{aligned}\therefore t &= \frac{ml_{\text{water}}}{P} \\ &= \frac{0.500 \times 2.26 \times 10^6}{1\,500} \\ &= 753 \text{ s}\end{aligned}$$

The correct time is likely to be more than the calculated time, as no allowance has been made for the energy loss from the heater to the outside or the energy gained by the kettle itself.

### Example 5.16

The graph in Figure 5.42 shows how temperature varies with time when 1 kg of ice at  $-10^\circ\text{C}$  is converted into 1 kg of steam at  $100^\circ\text{C}$  under standard atmospheric pressure. Calculate the heat energy required to convert ice into steam given: Specific heat capacity of ice =  $2\,100 \text{ J/kg K}$ , specific heat capacity of water =  $4\,200 \text{ J/kg K}$ , specific latent heat of fusion of ice =  $3.36 \times 10^5 \text{ J/kg}$ , specific latent heat of vaporisation of water =  $2.26 \times 10^6 \text{ J/kg}$ .

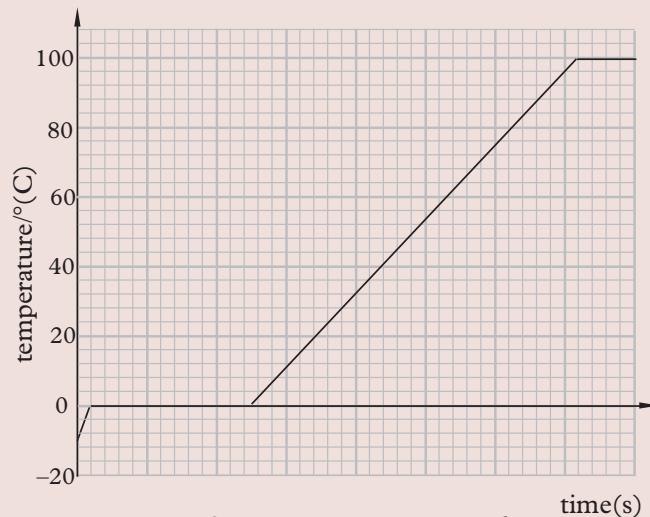


Fig 5.42: Temperature – time graph

### Solution

Heat energy required to:

1. raise the temperature of ice from  $-10^\circ\text{C}$  to  $0^\circ\text{C}$  is given by

$$Q_1 = (mc\Delta\theta)_{\text{ice}} = 1 \times 2\,100 \times 10 \text{ J} = 21\,000 \text{ J}$$

2. convert ice at  $0^\circ\text{C}$  to water at  $0^\circ\text{C}$  is given by

$$Q_2 = (ml)_{\text{ice}} = 1 \times 3.36 \times 10^5 \text{ J} = 336\,000 \text{ J}$$

3. raise the temperature of water from  $0^\circ\text{C}$  to  $100^\circ\text{C}$  is given by

$$Q_3 = (mc\Delta\theta)_{\text{water}} = 1 \times 4\,200 \times 100 \text{ J} = 420\,000 \text{ J}$$

4. convert water at 100 °C to steam at 100 °C is given by

$$Q_4 = (ml)_{\text{water}} = 1 \times 2.26 \times 10^5 \text{ J} = 2\,260\,000 \text{ J}$$

∴ Total heat energy required to convert ice into steam is given by

$$\begin{aligned} Q &= Q_1 + Q_2 + Q_3 + Q_4 \\ &= 21\,000 + 336\,000 + 420\,000 + 2\,260\,000 = 3.04 \times 10^6 \text{ J} \end{aligned}$$

### Example 5.17

In Example 5.16, calculate the ratio of  $l_w$  to  $l_{\text{ice}}$ , if the same electrical heater is used throughout the experiment, the time taken to convert ice at 0 °C to water at 0 °C is 168 s and the time taken to convert water at 100 °C to steam is 1 130 s.

### Solution

Assuming electrical energy spent = heat energy gained

$$VI t = ml_{\text{ice}}$$

$$\therefore Pt_1 = ml_{\text{ice}} \dots (i)$$

$$\text{Similarly } Pt_2 = ml_{\text{water}} \dots (ii)$$

$$\text{Dividing equation (ii) by (i) } \frac{Pt_2}{Pt_1} = \frac{ml_{\text{water}}}{ml_{\text{ice}}}$$

$$\therefore \frac{l_{\text{water}}}{l_{\text{ice}}} = \frac{1\,130}{168} = 6.73$$

### Exercise 5.7

Where necessary, take:

Specific heat capacity of ice = 2 100 J/kg K

Specific heat capacity of water = 4 200 J/kg K

Specific latent heat of fusion of ice =  $3.36 \times 10^5$  J/kg K

Specific latent heat of vaporisation of water =  $2.26 \times 10^6$  J/kg K

1. Define the terms: melting, boiling, melting point, boiling point.
2. Sketch a graph to show how temperature varies with time when ice at  $-8$  °C is converted to water at 16 °C.
3. (a) Define (i) the latent heat of fusion (ii) latent heat of vaporisation of a substance.  
(b) Why do we use the term 'latent' heat?

4. (a) Define the term specific latent heat of fusion of ice.  
(b) With the aid of a diagram, describe an experiment you could conduct in order to determine the specific latent heat of fusion of ice.
5. Calculate the amount of heat energy required to convert 2.5 kg of ice at  $0\text{ }^{\circ}\text{C}$  to water at  $0\text{ }^{\circ}\text{C}$ .
6. (a) How much heat energy is required to convert 2.0 kg of ice at  $-10\text{ }^{\circ}\text{C}$  to water at  $20\text{ }^{\circ}\text{C}$ ?  
(b) If an electric heater rated 1.0 kW is used, calculate the time taken to heat ice at  $-10\text{ }^{\circ}\text{C}$  to water at  $20\text{ }^{\circ}\text{C}$ ? State the assumption you have made in arriving at your answer.
7. (a) Define the term specific latent heat of vaporisation of water.  
(b) With the aid of a circuit diagram describe an experiment you would conduct to determine the specific latent heat of vaporisation of water.
8. An electric kettle rated 2.5 kW is used to boil 2.0 kg of water at  $100\text{ }^{\circ}\text{C}$  into steam. Calculate the mass of water converted into steam if the kettle was used for 6 minutes.
9. An electrical kettle rated 1.5 kW is used in an experiment to convert 200 g of ice at  $-5\text{ }^{\circ}\text{C}$  to steam at  $100\text{ }^{\circ}\text{C}$  under standard atmospheric pressure. Calculate the time for which the kettle has to be used in the above experiment.

#### 5.4.4 Applications of specific heat capacity

##### Activity 5.31

To identify and describe the application of specific heat capacity in our daily lives

##### Materials

- Internet
- Reference books

##### Steps

1. You have learnt about specific heat capacity, how is it useful in our daily lives
2. With the help of internet and reference books, conduct a research on application of specific heat capacity. Identify those that are not highlighted in this book. Note them in your notebook.
3. Represent your findings to the whole class

Specific heat capacity has many applications in our daily life. The following are a few examples:

- (a) A material with high specific heat capacity absorbs a lot of heat with only a small rise in temperature. This accounts for the efficiency of water as a coolant in a car radiator and of hydrogen gas in enclosed electric generators.
- (b) Substances with low specific heat capacities are quickly heated up; they experience a greater change in temperature after gaining a small amount of heat energy. For this reason, they are used to make cooking utensils such as frying pans, pots and kettles.
- (c) Sensitive thermometers are made from materials with low specific heat capacity in order to detect and accurately show rapid change in temperature, even for small amounts of heat energy.
- (d) Materials with high specific heat capacity are suitable for making handles of heating devices like kettles, pans and oven covers. This is because they do not get very hot easily when they absorb high amounts of heat energy.

### Unit summary and new words

- Heat is a form of energy which is transferred from a region of higher temperature to a region of lower temperature.
- The SI unit of heat energy is Joule (J).
- Two substances of equal masses can be at the same temperature but contain different amounts of heat energy and vice-versa.
- Heat energy can be transferred by three different modes: conduction, convection or radiation.
- Solids are heated by conduction and fluids by convection. Radiation can take place through vacuum.
- We get heat energy from the sun by radiation.
- The quantity of heat transferred depends on the following factors:
  - (a) The temperature difference.
  - (b) The nature of the materials.
  - (c) The cross-sectional area.
  - (d) The length of the material.
  - (e) The time taken to transfer heat.
- Heat capacity of a substance is the quantity of heat energy required to change the temperature of the substance by 1 K.
- Specific heat capacity of a substance is the quantity of heat energy required

to change the temperature of 1 kg of the substance by 1 K. Whenever there is a change in temperature of a substance, the quantity of heat energy involved is given by,  $Q = mc\Delta\theta$ .

- Latent heat of fusion of a substance is the quantity of heat energy required to change the substance from the solid state to the liquid state without any change in temperature at a constant pressure.
- Specific latent heat of fusion of a substance is the quantity of heat energy required to change 1 kg of a substance from the solid state to the liquid state without any change in temperature at a constant pressure.
- Specific latent heat of vaporisation of a substance is the quantity of heat energy required to change 1 kg of a substance from the liquid state to the vapour state without any change in temperature at a constant pressure.
- Whenever there is a change of state of a substance at constant temperature, the quantity of latent heat involved,  $Q = ml$ .

## Unit Test 5

**For questions 1 – 5, select the correct answer from the choices given.**

1. Radiation in a thermos flask is minimized by
 

<b>A</b> Cork	<b>B</b> Vacuum
<b>C</b> Felt pad	<b>D</b> Silvered glass water
2. A dull black surface is a good
 

<b>(i)</b> Absorber of heat energy	
<b>(ii)</b> Emitter of heat energy	
<b>(iii)</b> Reflector of heat energy	
<b>A</b> (i) only	<b>B</b> (i) and (ii) only
<b>C</b> (ii) and (iii) only	<b>D</b> (i), (ii) and (iii)
3. Radiation is the transfer of heat \_\_\_\_\_
 

<b>A</b> in a liquid which involves the movement of the molecules.	
<b>B</b> from one place to another by means of electromagnetic waves.	
<b>C</b> through a material medium without the bulk movement of the medium.	
<b>D</b> through a fluid which involves the bulk movement of the fluid itself.	
4. The mode of transfer of heat between the boiler and the storage tank of a hot water supply system is
 

<b>A</b> radiation	<b>B</b> conduction
--------------------	---------------------

**C** convention**D** evaporation

5. The transfer of heat by the actual movement of molecules of matter takes place

**A** only in liquid**B** only in gases**C** in solids and liquid**D** in liquids and gases

6. Match each heat transfer mechanisms to its description

Conduction

Electromagnetic waves

Evaporation

Transfer of vibrational energy from particle to particle

Radiation

Escaping of particles from the surface of a liquid

Convection

Movement of particles due to changes in density

7. Fill in blanks

(a) The specific latent heat of fusion is the energy required to \_\_\_\_\_ a kg of solid.

(b) The specific latent heat of vaporization is the energy required to \_\_\_\_\_ a kg of liquid.

(c) The specific heat capacity is the energy required to increase the \_\_\_\_\_ of \_\_\_\_\_ kg of material by  $1^{\circ}\text{C}$ .

8. Define the terms:

**(a)** heat capacity**(b)** specific heat capacity of a substance

9. Calculate the heat capacity if 8 000 J of heat is used to cool a solid of mass 1 kg from  $80^{\circ}\text{C}$  to  $20^{\circ}\text{C}$ .

10. Calculate;

(a) the heat energy required to raise the temperature of 200 g of gold of specific heat capacity  $130\text{ J/kg K}$  by  $1\ 000^{\circ}\text{C}$ .

(b) the heat energy given out when a piece of hot iron of mass 2 kg cools down from  $450^{\circ}\text{C}$  to  $25^{\circ}\text{C}$ , if the specific heat capacity of iron is  $460\text{ J/kg K}$ .

11. In experiment requiring storage of heat energy, water is preferred to other liquids. Give two reasons for this.

12. Calculate the heat energy required to raise the temperature of 400 g of water from  $25^{\circ}\text{C}$  to  $45^{\circ}\text{C}$ . Specific heat capacity of water =  $4\ 200\text{ J/kg }^{\circ}\text{C}$ .

13. Find the initial temperature of aluminium if 2 400 J of heat is used to raise the temperature of 50 g of aluminium to  $62^{\circ}\text{C}$ . Specific heat capacity of aluminium is  $900\text{ J/kg K}$ .

14. 620 000 J of heat energy is supplied to raise the temperature of a solid of mass



10 kg from 40 °C to 75 °C. Calculate the specific heat capacity of the solid.

15. Calculate the heat required to heat 0.5 kg of ice at  $-8\text{ }^{\circ}\text{C}$  to steam at  $100\text{ }^{\circ}\text{C}$ . (Specific heat capacity of ice =  $2\,100\text{ J/kg}\cdot\text{K}$ . Specific heat of fusion of ice is  $3.34 \times 10^5\text{ J/kg}$  and specific latent heat of vaporization of water =  $2.26 \times 10^6\text{ J/kg}\cdot\text{K}$ .)
16. Explain the following statements:
- A metallic seat seems to be hotter during the day and colder during the night than a wooden seat under the same conditions.
  - The bottom of cooking vessels are usually blackened.
  - It is safer to hold the other end of a burning match stick.
17. A cross-section of a solar heater panel fitted to the roof of a house is shown below (Fig. 5.43).

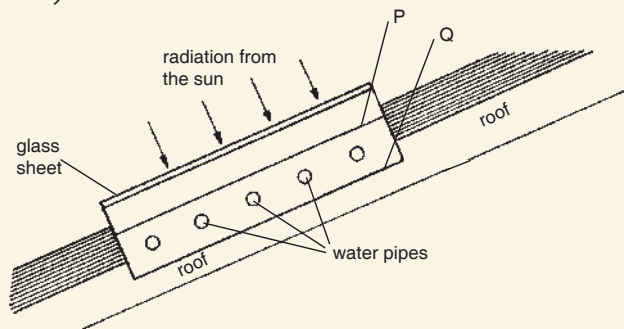


Fig. 5.43

- Surface P is dull black whereas surface Q is covered in shiny aluminium foil. Give a suitable reason for each choice.
  - What is the purpose of the front glass sheet?
18. A mass of 700 g of copper at  $98\text{ }^{\circ}\text{C}$  is put into 800 g of water at  $15\text{ }^{\circ}\text{C}$  contained in a copper vessel of mass 200 g and the final resulting temperature of the mixture is found to be  $21\text{ }^{\circ}\text{C}$ . Calculate the specific heat capacity of copper.
19. A refrigerator converts 1 kg of water at  $25\text{ }^{\circ}\text{C}$  into ice at  $-5\text{ }^{\circ}\text{C}$  in 2.5 hours. Show that the rate at which heat is extracted from the refrigerator is about 50 J/s.
20. It takes 15 minutes for an electric kettle to heat a certain quantity of water from  $0\text{ }^{\circ}\text{C}$  to  $100\text{ }^{\circ}\text{C}$ . It requires 80 minutes to convert all the water at  $100\text{ }^{\circ}\text{C}$  into steam. Calculate the specific latent heat of vaporisation of water.
21. The graph in Figure 5.44 shows how 400 g of ice at  $-10\text{ }^{\circ}\text{C}$  would change with time, if it were to be heated at a steady rate of 600 W.

- (a) Explain in molecular terms, what has happened to the energy being supplied at  $0\text{ }^{\circ}\text{C}$ .
- (b) Use the graph to determine the specific latent heat of fusion of ice.

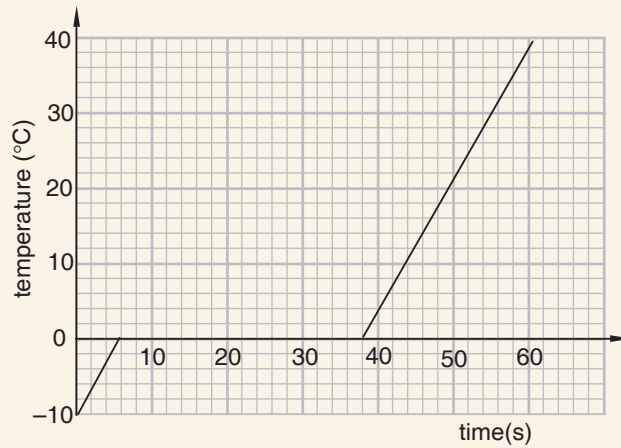


Fig. 5.44

## UNIT

## 6

## Laws of thermodynamics

**Key Unit Competence**

By the end of this unit the learner should be able to describe the internal energy of a system by applying laws of thermodynamics.

**Learning objectives****Knowledge and understanding**

- State the laws of thermodynamics.
- Describe applications of thermodynamics laws.
- Explain the functioning of the refrigerator.
- Describe heat exchanges.
- Explain the work done on a system when heat energy increases or decreases.
- Use kinetic theory of matter to explain internal energy and changes of states.

**Skills**

- Show how heat energy increase with an increase of external work done.
- Determine the quantity of heat using the method of mixtures.
- Demonstrate the change of state as a result of internal energy.
- Carry out an investigation on how one state is transformed into another state.
- Differentiate internal energy and external energy as an increase in energy due to work done on a system.

**Attitude and value**

- Appreciate the importance of internal energy in increasing the temperature of a body.
- Be aware of the rate at which bodies loose energy.
- Adapt scientific method of thinking
- Recognise the need of acquiring knowledge of analysing and modelling physical processes using laws of thermodynamics.



## Introduction

### Unit Focus Activity

#### Materials

- Beaker
- Wire gauze
- Bunsen burner
- Thermometer
- Tripod stand
- Water

#### Part 1

1. Set up the apparatus as shown in Fig. 6.1.
2. Record the initial temperature of water in the beaker.
3. Heat the water for 2 min and record its final temperature.
4. Stop heating and wait for the water to cool for 1 min. Record its final temperature.
5. Explain how heat is transferred from one particle to another in the water.
6. Describe the effect of heat gain on the internal energy of a particle.



Fig. 6.1: Heating some water in a beaker

**Part 2**

1. (a) Define the term entropy.  
(b) How does entropy change in the water during:
  - (i) heating?                      (ii) cooling?
2. (a) State the first and second laws of thermodynamics  
(b) Explain how these two laws govern the changes in the thermal energy of the water during:
  - (i) heating                      (ii) cooling
3. Describe how the principle of heat exchange is demonstrated during the cooling of the water.

**6.1 Introduction to thermodynamics****Activity 6.1**

To define thermodynamics and distinguish between the three types of systems

**Materials**

- Water in a beaker
- Bunsen burner
- Thermometer
- Solid ice

**Steps**

1. From knowledge you acquired in unit 5, how does heat travel from one end to another in different states of matter?
2. How do particles behave in each state of matter during heat transfer?
3. What is thermal dynamics as applied to heat transfer?
4. Heat the water in the beaker till it boils. Measure and record the temperature.
5. Dip the solid ice into the boiled water, measure the temperature again. Compare the reading with that of step 4. What do you observe? Explain
6. Distinguish between open, closed and isolated system. Classify the behaviour the beaker and its contents in steps 3 and 4 as one of these systems giving reason for your answer.
7. Note down your findings in your note books.
8. Discuss your findings as the whole class with the help of the teacher and note them down in your note books.

The term *thermodynamics* is composed of two words '*thermo*' and '*dynamics*'.

Dynamics is the study of why things move the way they do. For instance, in the unit on Newton's laws, we looked at what compels bodies to accelerate and how they move. The prefix '*thermo*' means **heat**.

Therefore, thermodynamics **is the study of systems involving energy in the form of heat and work**. A good example of a thermodynamic system doing work is a gas confined by a piston in a cylinder. If the gas is heated, it will expand, doing work on the piston by pushing it.

Since thermodynamics deals with the flow of heat in and across systems, it is important to first remind ourselves the different types of systems.

There are three types of systems in thermodynamics: open, closed, and isolated.

- An **open system** is a system that exchange both energy and matter with its surroundings. An open heating pot is an example of an open system, because heat and water vapour are lost to the air.
- A **closed system** is a system that can exchange only energy with its surroundings, but not matter. A heating pot with a very tightly fitting lid would be approximated to be a closed system.
- An **isolated system** is a system that cannot exchange either matter or energy with its surroundings. Perfect isolated systems are very rare, but a completely insulated drinks cooler with a lid would ideally represent an isolated system. The items inside can exchange energy with each other, but they exchange negligible or no heat energy with the outside environment.

## 6.2 Internal energy of a system

### Activity 6.2

#### To demonstrate and explain internal energy of a system

#### Materials:

- Reference books
- Internet
- Transparent container
- Marbles of two different colours

#### Steps

1. Open the transparent container and drop the marbles of one colour followed by those of the other colour.
2. Shake the container and observe the marbles. What do you see? Did the marbles remain at the same position?
3. Suppose the container is the system and the marble is the internal energy. Explain how internal energy flows inside a substance.

4. Now conduct a research from internet or reference book on the definition of internal energy.
5. Compare and discuss your findings with other groups in class.
6. Write down your findings in your note book.

The internal energy of a system is identified with the random, disordered motion of molecules. The total (internal) energy in a system includes:

- translational kinetic energy
- vibrational and rotational kinetic energy
- potential energy from intermolecular forces

The symbol for internal energy change is  $U$ .



Note that same quantities of substances at the same temperature do not necessarily possess the same amount of internal energy. For example, one gram of water at  $0^{\circ}\text{C}$  compared with one gram of copper at  $0^{\circ}\text{C}$  do not have the same internal energy. This is because, though their kinetic energies are equal, water has a much higher potential energy causing its internal energy to be much greater than the copper's internal energy.

### 6.3 First law of thermodynamics

#### Activity 6.3

#### To demonstrate the first law of thermodynamic

##### Materials:

- Beaker
- Water
- Bunsen burner
- Thermometer

##### Steps

1. Put some water in a beaker and dip the thermometer in the water. Note the temperature of the water.
2. Place the beaker on bunsen burner and observe what happens as you continue to heat.
3. Observe what happens to the water particle as the water boils.
4. Describe energy transformation taking place in the set up during heating and at boiling point.

5. State the law that governs the energy transformations that govern the heat energy exchange in this activity.

We have already learnt about the law of conservation of energy which states that energy can neither be created nor destroyed but can be converted from one form to another. This law is obeyed by all systems including thermodynamic systems. In thermodynamic systems, the law of conservation of energy governs the energy transformations involving applied heat and internal energies. In such systems for example, the heat applied (external energy) and the work done by the environment onto the system are converted to internal energy. Specifically, for thermodynamic systems, the law of conservation of energy is summarized into what is known as the **first law of thermodynamics**.

The law states *that the change in the internal energy ( $\Delta U$ ) of a system is equal to the sum of the heat ( $Q$ ) that flows across its boundaries and the work ( $W$ ) done on the system by the surroundings.*

The law is mathematically represented as:

Change in internal Energy of a system ( $\Delta U$ )	=	Heat dissipated or absorbed by the system ( $Q$ )	+	Work done by or to the system ( $W$ )
$\Delta U = Q + W$				



**Note:**

- (a) The absorption of heat by the system tends to raise the energy of the system and vice versa.

Therefore, in the equation, we take heat ( $Q$ ) to be positive if it is supplied to the system and negative if heat is dissipated (removed) from the system.

- (b) The performance of work by the system requires use of energy by the system hence lowers the energy of the system, and vice versa.

Therefore, in the equation, we take work done as positive if it is done on to the system and negative if it is done by the system.

**Example 6.1**

A gas in a system has constant pressure. The surroundings lose 49 J of heat to the system and does 316 J of work onto the system. What is the change in internal energy of the system?



**Solution**

Let us first consider the relationship between the system and the surroundings. The surrounding loses heat and does work onto the system. Therefore, we take  $Q$  and  $W$  as positive in the equation.

Therefore,

$$U = Q + W$$

$$\begin{aligned} U &= 49 \text{ J} + 316 \text{ J} \\ &= 365 \text{ J} \end{aligned}$$

**Example 6.2**

In a certain process, 450 J of work is done on the system. If the system gives off 124 J of heat, what is the change in internal energy of the system?

**Solution**

We take the heat ( $Q$ ) as negative because it is given off by the system.

We take the work done ( $W$ ) as positive because it is done on the system.

Therefore,

$$\begin{aligned} U &= Q + W \\ &= -124 \text{ J} + 450 \text{ J} \\ &= 226 \text{ J} \end{aligned}$$

**Example 6.3**

In a certain process, 523.6 J of heat is added to a system. The system does work equivalent to 781.4 J by expanding against the surrounding atmosphere. What is the change in internal energy for the system?

**Solution**

We take the heat ( $Q$ ) as positive because it has been added to the system.

We take the work done ( $W$ ) as negative because it is done by the system.

Therefore,

$$\begin{aligned} U &= Q + W \\ &= 523.6 \text{ J} - 781.4 \text{ J} \text{ (In this case, } W \text{ is negative)} \\ &= -257.8 \text{ J} \\ &= -257.8 \text{ J} \end{aligned}$$

**Exercise 6.1**

**For questions 1 - 3 select the most appropriate response from the choices given.**

- Which has more internal energy?
  - Bathtub full of cool water
  - Cup of hot water
- If a piece of aluminum is placed in contact with both a bathtub full of cool water and a cup of hot water, which way will heat flow?
  - From the cup to the bathtub
  - From the bathtub to the cup
- A system has 30 J of heat added to it and in doing so, it does 25 J of work. Its change in internal energy will be:
 

A. +25 J	B. + 5 J	C. -5 J
D. -30 J	E. -25 J	

**Fill in the blank spaces.**

- Besides kinetic energy, molecules have rotational kinetic energy, potential energy due to forces between molecules and more. The total of all energies inside a substance is called \_\_\_\_\_?
- If heat flows from a cup of hot water to a bathtub full of cool water, the water in the cup will have a \_\_\_\_\_ in internal energy while the water in the tub will have an \_\_\_\_\_ in internal energy.

## 6.4 Second law of thermodynamics

### Activity 6.4

**To define and explain the term entropy**

#### Materials:

- |                                       |            |
|---------------------------------------|------------|
| • 20 red marbles and 20 green marbles | • a tray   |
| • Reference books                     | • Internet |

#### Steps

- Place the red marbles on one side in the tray and the green ones on the opposite side in an orderly manner.
- Shake the tray with your hands for some time then stop.

3. Observe the marbles. In what state are they, orderly as at the beginning or disorderly?
4. Based on your observations in step 1(a) to (c), describe how the order of particles in a substance is affected, when the internal energy of the substance is increased by heating.
5. Research the meaning of the term entropy from the Internet or reference books.

### Activity 6.5

### To demonstrate and state the Second law of thermodynamics

#### Materials:

- A beaker
- Burner water
- Ice
- Thermometer

#### Steps

1. Warm some water in a beaker.
2. Remove the beaker from the heat and place it on the bench. Place the thermometer in the warm water and record its temperature.
3. Place the piece of ice into the warm water in the beaker. Observe what happens to the temperature of the water as the ice eventually melts.
4. Discuss with your classmate whether the two process that took place in step 3 would be reversed in the same time if after taking place, the beaker is heated again.

Entropy is the measure of a system's thermal **energy** per unit **temperature** that is not available to do useful **work**.

Since work arises from ordered motion of molecules, the amount of **entropy** is also a measure of the molecular disorder, or randomness of a system. The concept of entropy helps us to understand the direction in which spontaneous processes happen in systems. It enables us to understand which processes are possible or impossible, without violating the law of **conservation of energy**.

For example, when a block of ice is placed on a hot stove, it surely melts and at the same time the stove cools. Such a process is called **irreversible** because after taking place, heating the stove again will not make the melted water to freeze back to ice again.

A German physicist called **Rudolph Julius Emanuel Clausius** in 1850, summarised the concept of entropy in what is now known as the **Second law of thermodynamics** in 1850.

The law states that *the spontaneous change for an irreversible process in an isolated system always proceeds in the direction of increasing entropy. In other words, the entropy of any isolated system always increases.*

For example, the block of ice and the stove mentioned earlier constitute two parts of an isolated system for which total entropy increases as the ice melts.

Different scientists have come up with different formulations/statements of this law to describe the same phenomena. The simplest of all these formulations states the second law as follows:

*'Heat flows spontaneously from a hotter object to a colder one, but not in the opposite direction; the reverse cannot happen without the addition of energy'.*

### Exercise 6.2

**Select the most appropriate response from the once given.**

- The second law of thermodynamics would back up this statement: For natural processes, in the long run, entropy decreases.
  - True
  - False
- Which of the following is the best definition of entropy?
  - Increase in the concentration of a substance in a solution
  - An energetically favorable reaction
  - Increase in disorganization within a system
  - Increase in organization within a system
- In terms of energy changes that take place daily, the universe tends to move towards:
 

<b>A.</b> the north	<b>B.</b> the sun
<b>C.</b> order	<b>D.</b> disorder
- \_\_\_\_\_ is the measure of randomness or disorder.
 

<b>A.</b> Metabolism	<b>B.</b> Synthesis
<b>C.</b> Entropy	<b>D.</b> A coupled reaction
- The second law of thermodynamics will back up this statement: Heat will never flow from a cold object to a hot object!
  - True
  - False

## 6.5 Heat exchange

### Activity 6.6

To demonstrate heat exchange using cold and hot water

#### Materials:

- Water
- Tripod stand
- Stirrer
- Beakers A and B
- Bunsen burner
- Thermometers
- Wire gauze

#### Steps

1. Pour equal amounts of water into beakers A and B. Measure and note down the temperature of water in beaker B.
2. Place the wire gauze on the tripod stand and place the Bunsen burner below it. Light the Bunsen burner.
3. Place beaker A on the set up in step 2 and allow the water to heat upto above the room temperature. Measure and record its temperature using a thermometer. Compare the temperature of water in beaker A and B. Which one is higher?
4. Put off the Bunsen flame and mix the water in B with that in A and stir well.
5. Measure and record the final temperature of the mixture.
6. Compare the final temperature of the mixture and initial temperature of water in beaker B. Which one is higher? How has the initial temperature of water in B changed in the final mixture, increased or decreased? Explain.
7. During the mixing up of the water in A and B, in what direction did the heat move? A to B or vice versa?
8. In one statement, summarize the direction of heat transfer between cold and hot regions.

Heat transfer *is the exchange of thermal energy between physical systems*. It moves from one system to another because of **temperature difference** in the given systems. The direction of heat transfer is always *from the region of high temperature* to that of *lower temperature*, and is governed by the Second law of thermodynamics. The region with higher temperature is known as the *heat source* and the one with lower temperature as the *heat sink*.

In other words, *heat transfer occurs in a direction that increases the entropy of the collection of systems and changes the internal energy of the two systems involved in the transfer*. This is known as the principle of heat exchange.

The rate of heat transfer is dependent on the temperatures of the systems and the properties of the intervening medium through which the heat is transferred. A thermal equilibrium in the two system is reached when all involved bodies and the surroundings reach the same temperature.

The heat will continue flowing till the two systems are in **thermal equilibrium** (at equal temperatures).

### Activity 6.7

To show the quantity of heat using the principle of heat exchange

#### Materials:

- Water
- Tripod stand
- Stirrer and beam balance
- Beakers
- Bunsen burner
- Beam balance
- Thermometer
- Wire gauze

#### Steps

1. Pour water into beakers A and B, measure and note down the mass using a beam balance of the water in both beakers i.e.  $m_1$  and  $m_2$  respectively and temperature,  $t_1$  of water in beaker B.
2. Place the wire gauze on the tripod stand and place the Bunsen burner below it, light the Bunsen burner.
3. Place beaker A on the set up in step 2 and allow the water to heat up above the room temperature, then measure and record its temperature,  $t_2$ .
4. Put off the Bunsen flame and mix the water in B with that in A and stir well.
5. Measure and record the final temperature,  $t_3$  of the mixture.
6. What conclusion can you make from your findings?

From the principle of heat exchange,

Heat lost by a hot object = heat gained by a cold object.

The specific heat capacity of water being a standard figure  $4200 \text{ J/kg } ^\circ\text{C}$ .

We can find either the quantity of heat lost by the hot water or the quantity of heat gained by the cold water using the formula  $Q = mc\Delta\theta$ , where  $Q$  is the quantity of heat given out or absorbed,  $m$ , the mass of the substance,  $c$ , is the specific heat capacity of a substance and  $\Delta\theta$ , is the temperature change.

#### Example 6.4

In an experiment similar to Activity 6.7, the following data was obtained. Mass of the solid = 50 g, specific heat capacity of the solid =  $400 \text{ J/kg K}$ , initial temperature of the hot solid =  $100 \text{ }^\circ\text{C}$ , mass of the container = 200 g, specific heat capacity of the material of the container =  $400 \text{ J/kg K}$ , mass of water = 100 g, initial temperature of the water and the container =  $22 \text{ }^\circ\text{C}$ .

When the hot solid was transferred into the cold water in the container, the temperature of the mixture was  $25 \text{ }^\circ\text{C}$ . Calculate the specific heat capacity of water. Use the data to calculate the specific heat capacity of water.

**Solution**

Let the specific heat capacity of water be  $c_w$

$$\begin{aligned}\text{Heat lost by the hot solid} &= mc\Delta\theta = 0.050 \times 400 \times (100 - 25) \\ &= 1\,500 \text{ J}\end{aligned}$$

$$\begin{aligned}\text{Heat gained by the container and water} &= mc\Delta\theta_{\text{container}} + mc\Delta\theta_{\text{water}} \\ &= 0.200 \times 400 \times (25 - 22) + 0.100 \times c_w (25 - 22) \\ &= 80 \times 3 + 0.1 c_w \times 3 \\ &= (80 + 0.1 c_w)3\end{aligned}$$

Assuming no energy losses to the surroundings

Heat lost = heat gained

$$1\,500 = (80 + 0.1 c_w)3$$

$$500 = 80 + 0.1 c_w$$

$$420 = 0.1 c_w$$

$$\therefore c_w = 4\,200 \text{ J/kg K}$$

**6.6 Change of state and kinetic theory of matter****Activity 6.8**

To describe the change of state and kinetic theory of matter

**Materials:**

- Solid ice
- Bunsen burner
- Thermometer

**Steps**

1. State the three states of matter.
2. Name the process of the change of states shown with arrows in the Fig. 6.2.

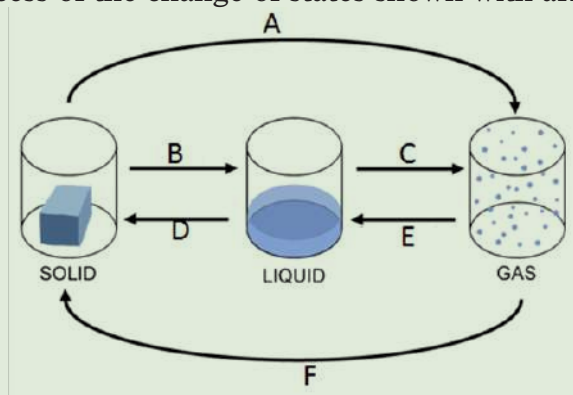


Fig. 6.2: Diagram of change in state

3. Highlight the key facts in the kinetic theory of matter.
4. With the help of your teacher harmonize your findings, write down the notes in your books.

When a pure solid is heated, its temperature rises until it starts to **melt**. At its melting point, any additional heat supplied does not change its temperature. When the pure solid becomes a pure liquid (a change in state), further heating raises the temperature of the liquid until it starts to **boil**.

At its boiling point, any additional heat supplied causes **boiling** without any temperature rise. When the pure liquid becomes a pure gas (a change in state), further heating will again raise the temperature of the gas.

When a gas is cooled, it reaches a temperature where it condenses to a liquid at a constant temperature. When the liquid is cooled, it reaches a point where it freezes to a solid at a constant temperature.

### Important!

During the changing of state, the temperature of the gas/liquid/solid is constant.

The properties of the molecules of the substances vary with the amount of thermal energy they possess.

The changes of state can be explained by using the **kinetic theory of matter**. The kinetic theory of matter is theory that tries to explain the properties and behaviours of the three states of matter. It makes the following **three assumptions**:

#### 1. Matter consists of small particles

The first assumption is that matter consists of a large number of very small particles either individual atoms or molecules.

All matter (solid, liquid, and gas) is made up of tiny particles called atoms, or atoms that are joined to form molecules.

#### 2. Large separation between particles

The second assumption describes the separation of the particles:

In a gas, the separation between particles is very large compared to their size, such that there are no attractive or repulsive forces between the molecules.

In a liquid, the particles are still far apart, but are close enough that attractive forces confine the material to the shape of its container.

In a solid, the particles are so close that the forces of attraction confine the material to a specific shape. Fig 6.3 shows the separation between particles of matter.



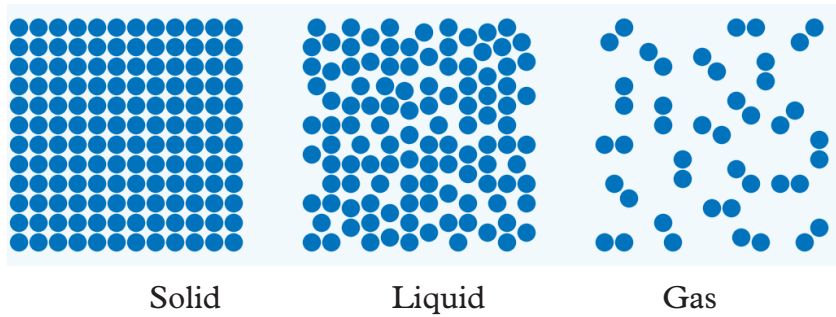


Figure 6.3. Separation between particles of matter

### 3. Particles in constant motion

The third assumption is that each particle in matter is in constant motion. Particles of a solid are held very close to each other by strong attractive forces. These forces hold the solid particles in place and gives a solid fixed size and shape.

Liquid particles have more energy than solids allowing them to move around more freely, and spread out more than those of a solid and therefore increasing the space between the particles. This is why a liquid will take the shape of its container up to its surface. However, liquids have definite volume.

Gas particles have more energy than liquids hence their particles move more freely. Therefore, gases expands to fill its entire container. The particles of a gas are so far apart that the attractive forces between them are assumed to be negligible. The particles are viewed as independent from each other, meaning that the gas is the opposite of a solid and has neither a fixed size nor shape.

The velocity of each particle in matter determines its kinetic energy. There is an exchange or transfer of energy between particles both atoms and molecules during collisions between them.

Fig 6.4 shows movement of particles in matter.

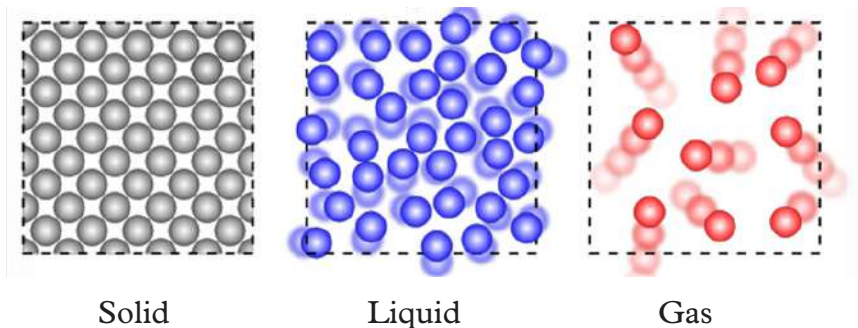


Figure 6.4. Movement of particles in matter

Based on these assumptions, the kinetic theory states that *matter is composed of a large number of small particles that are in constant motion.*

The theory helps to explain:

1. The flow or transfer of heat and the relationship between pressure, temperature and volume properties of gases.
2. Why substances change state under certain conditions .e.g. solid to liquid to gas and vice versa. The change of state occurs when energy is added to or taken away from matter usually in the form of heat.

### Exercise 6.3

**Select the most appropriate answer from the choices given.**

1. Which one of the following is an assumption of the kinetic theory of matter?
  - A. Gases are the same in all matter.
  - B. Matter is the same as kinetic energy.
  - C. Matter consists of tiny particles.
  - D. None is correct.
2. What happens when particles collide?
  - A. Molecules break into atoms.
  - B. They exchange or transfer kinetic energy.
  - C. They change the state of the material.
  - D. None is correct.
3. What determines how close molecules are to each other?
  - A. The diameter of the molecules.
  - B. There is no way to tell.
  - C. The state of phase of the material.
  - D. The diameter of the container holding them.
4. What leads to a change of state in matter?
  - A. A change in the number of particles.
  - B. A change in the amount of internal energy.
  - C. A change in the direction of particle movement.
  - D. A change in the shape of the container.
5. Matter consists of tiny particles termed as \_\_\_\_\_?
  - A. Matter
  - B. Atoms
  - C. Ions
  - D. Elements

6. \_\_\_\_\_ is the reverse of evaporation.
- A.** Boiling    **B.** Freezing  
**C.** Melting     **D.** Condensation
7. A temperature of 0 K is known as \_\_\_\_\_.
- A.** The freezing point of air    **B.** 0°C  
**C.** Absolute zero                                   **D.** The melting point of water
8. The temperature of a substance \_\_\_\_\_ as its heat of fusion is supplied to melt it.
- A.** Remains at 0 K                                **B.** Remains constant  
**C.** Decreases                                       **D.** Increases rapidly
9. Which of the following is vapour?
- A.** Oxygen    **B.** Hydrogen  
**C.** Steam    **D.** Helium
10. The constant, random motion of tiny chunks of matter is called \_\_\_\_\_.
- A.** linear motion                                    **C.** Brownian motion  
**B.** Kinetic motion                                **D.** Parabolic trajectory

## 6.7 Applications of the principle of thermodynamics

### 6.7.1 Functioning of refrigerators

#### Activity 6.9

To show the basic working principle of a refrigerator

#### Materials

- Tomato
- Ether.

#### Steps

1. Feel the temperature of tomato with the back of your palm.
2. Pour a little ether on the tomato and once again feel its temperature.
3. Compare the temperatures of the tomato in steps 1 and 2. Which one is high?
4. Suggest a reason for your answer in step 3.
5. Basing on the reason you have given in Step 4, explain to your classmates how the refrigerator operates.
6. Report your findings to the whole class with assistance of your teacher, make short notes from the discussion.

When a volatile liquid is poured onto a surface, it quickly evaporates by absorbing heat from the surface, due to the temperature difference between the two. As a result, the surface is cooled. This is why we say *evaporation causes cooling*. This simple fact is applied in the working of a refrigerator. Let us now discuss its working in details.

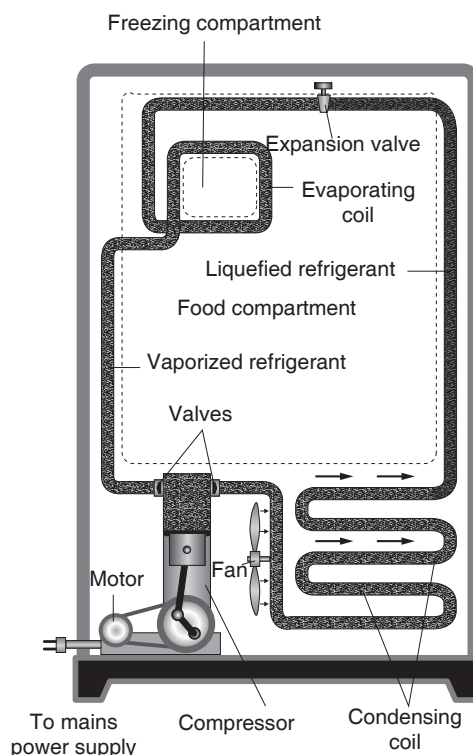
Fig. 6.5(a) shows a photograph of a commercial refrigerator. Fig 6.5 (b) shows the main parts of a refrigerator.

The main parts of the refrigerator are the; the compressor, condenser, evaporator and the expansion valve. The compressor and the condenser are outside the refrigerator while the evaporating coil and the expansion valve are inside it. The refrigerant, i.e. the liquid used in the refrigerator's circulatory system is Freon (dichloro-difluoro- methane) which is non-poisonous and odourless.

Fig. 6.5 shows the refrigerator and its parts.



Figure 6.5(a) A picture of refrigerator



(b) Picture of parts of a refrigerator

The refrigerant's vapour is drawn in by the compressor. It is then compressed and passed into the condensing coil, which is air cooled by a fan. The gas gets liquefied, losing its latent heat of vaporization. This liquid refrigerant is made to enter the evaporating coil, where the pressure is relatively low. The liquid at once evaporates at a lower pressure and the latent heat of vaporization required for the change of state is taken from the air in the freezing compartment and other food items stored in it. As a result of this, the temperature of the air in the refrigerator cabinet

is lowered to about  $7\text{ }^{\circ}\text{C}$ , an ideal temperature for storing most food items. The temperature quite close to the evaporating coil falls below the temperature of the ice due to large surface area of the coil. The gas goes back into the compressor, gets liquefied and the cycle repeats itself.

The refrigerator cabinet is well insulated so that no heat is conducted from outside into it. The temperature inside the cabinet is controlled by a thermostat (a bimetallic strip). When the temperature rises a few degrees above  $7\text{ }^{\circ}\text{C}$ , the thermostat makes electrical contact and starts the motor. When the temperature inside falls by the desired amount, the circuit is broken by the thermostat and the motor stops working.

## 6.8 Melting and solidification

### 6.8.1 Melting

#### Activity 6.10

#### To show the heating curve of ice

##### Materials:

- Thermometer
- Glass beaker
- Crushed ice
- Tripod stand
- Bunsen burner and wire gauze.

##### Steps

1. Take pure crushed ice at about  $-10\text{ }^{\circ}\text{C}$  and put it in a beaker placed on wire gauze on a tripod stand as shown in Fig. 6.6.
2. Note the initial temperature of the ice.
3. Light a Bunsen burner and adjust the blue flame to a small low temperature.
4. Note the temperature of ice at 30 seconds interval until the temperature of the container is about  $10\text{ }^{\circ}\text{C}$ .
5. Record your results as shown in Table 6.1
6. What happens to the amount of ice as heating continues?
7. Plot a graph of temperature against time
8. Explain the shape of the graph.

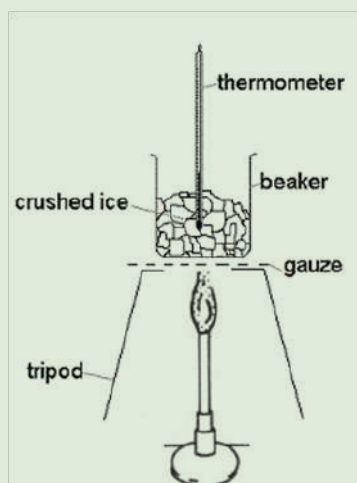


Fig. 6.6: Set up to show heating of ice

Table 6.1

Time (s)	0	30	60	90	120
Temperature ( $^{\circ}\text{C}$ )					

**Melting** is the change of state from a solid to a liquid. Melting of a pure substance occurs at a particular constant temperature called **melting point**.

Fig 6.7 shows a graph of temperature against time for ice.

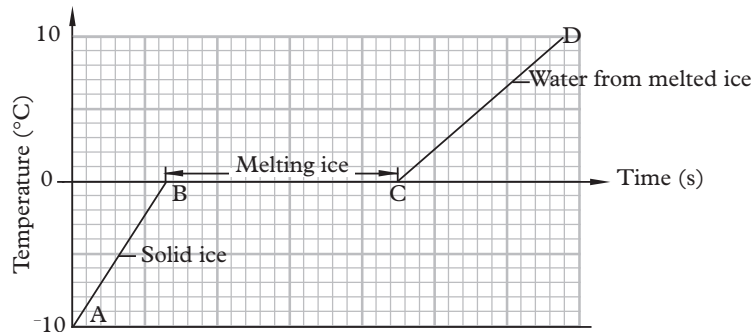


Fig. 6.7: Melting process of ice

The graph shows that

1. The temperature of ice rises steadily from  $-10^{\circ}\text{C}$  to  $0^{\circ}\text{C}$ . During this time, along AB, the ice remains as solid.
2. At  $0^{\circ}\text{C}$ , along the line BC, the temperature remains constant for a period of time. During this period, the ice is melting. During the melting process, solid and liquid exist in equilibrium.

**Step by step process of what happens during melting:**

- (i) Heat energy is absorbed by the solid particles.
  - (ii) Heat energy is converted to kinetic energy.
  - (iii) The kinetic energy of the particles increases and the particles in the solid vibrate faster.
  - (iv) At melting point, the particles have gained enough energy to overcome the attractive forces between particles.
  - (v) Particles starts to move away from their fixed position.
  - (vi) Liquid is formed.
  - (vii) The cause for constant temperature during melting: The absorbed heat energy during melting is used to weaken the attractive forces between particles and not the kinetic energy of the particles.
3. After all the ice has melted, the temperature of water starts rising again as seen along the line CD of the graph.
  4. The line AB of the graph is steeper than the line CD of the graph showing that the time taken to raise the temperature of ice by  $10^{\circ}\text{C}$  is less than the time taken to raise the temperature of water by  $10^{\circ}\text{C}$ . it is easier to raise the

temperature of ice than water. This means that the specific heat capacity of ice is less than that of water.

Activity 6.10 shows that when a substance is changing its state from solid to liquid, heat is required. Thermal energy absorbed during the melting process is called **latent heat**. There is no change of temperature, as shown in the part BC of the graph, until all the ice has melted. Conversely if water at  $0\text{ }^{\circ}\text{C}$  freezes to ice at  $0\text{ }^{\circ}\text{C}$ , it must give out the same heat energy.

If pressure remains constant, a solid substance melts or freezes at a specific temperature. The melting point of ice is  $0\text{ }^{\circ}\text{C}$  under standard atmospheric pressure.

### 6.8.2 Solidification

Fig 6.8 Shows the cooling curve for water.

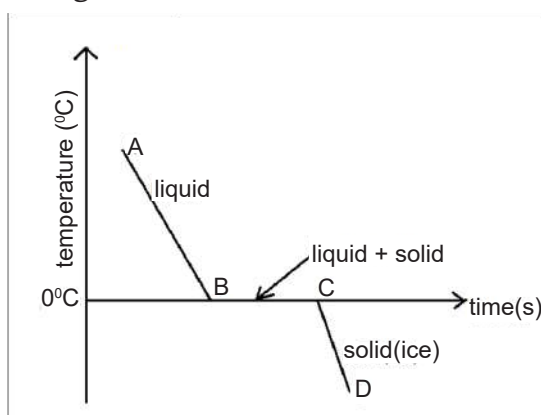


Figure 6.8. A cooling curve for water

The graph shows that:

1. The line AB represents water still in liquid state where molecules are free to move in random directions, colliding with each other and the walls of the container. The temperature of water falls steadily between points A and B.
2. At  $0\text{ }^{\circ}\text{C}$ , along the line BC, the temperature remains constant for a certain period of time. During this time, there is a mixture of a liquid and solid. i.e. water is observed to freeze (solidify). At C all the water has completely (frozen) changed to ice.
3. After all the water has solidified, the temperature of ice starts reducing again as seen along the line CD of the graph.



**Note:** Activities with other substances show a similar behaviour. This shows that kinetic theory can be applied to all substances.

**Solidification** is the change of state from a liquid to a solid. It is also known as



**freezing.** A pure substance freezes at a temperature equal to its melting point. Freezing of a substance occurs at a particular constant temperature called the **freezing point**.

### 6.8.3 Factors that affect melting/freezing point

#### (a) Pressure

Under standard atmospheric pressure, a pure substance always melts at a definite temperature. The melting point however changes with the change in pressure acting upon a substance. The change in the melting point due to change in pressure is however not large.

#### Activity 6.11

To show the effect of pressure on the melting point of ice.

#### Materials:

- Wire
- 2 Equal weight
- Block of ice
- 2 cement blocks
- Soft pad

#### Steps

1. Rest a large block of ice at  $0\text{ }^{\circ}\text{C}$  on two stools or two cement blocks.
2. Hang a thin copper wire around the block and attach two equal heavy weights to the ends of the wire as shown in Fig. 6.9. Observe and record what happens to the wire and the block of ice as time progresses.

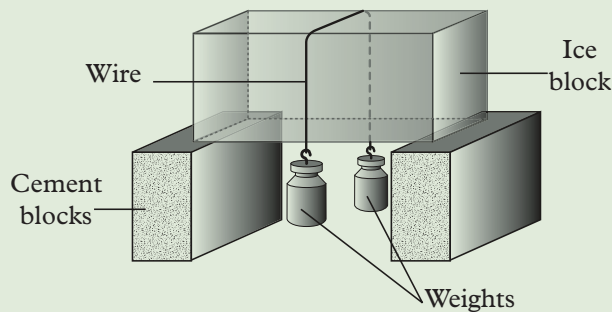


Fig. 6.9: Effect of pressure on melting point of ice

The wire completely cuts through the block of ice and the weights fall to the soft pad on the floor. Is the ice in one piece or two pieces?

In the above experiment, it is observed that initially as the pressure of the wire on the ice increases, the melting point of ice decreases and so the ice melts. The water flows above the wire. The latent heat of fusion required for the melting of ice comes from the copper wire. The water above the wire is no longer under pressure. As the pressure is released, the water which is at a temperature below zero freezes again binding the two pieces of ice together. During freezing heat



is given out by water and this heat is conducted down through the copper wire. This provides heat for further melting of the ice under the wire. At some point, the wire cuts right through the block of ice and falls to the floor, leaving ice still in a solid block.

This phenomenon in which ice melts when pressure is increased and again solidifies (freezes) when the pressure is reduced is called *regelation* (re-again: gelare-freeze)

Ice contracts on melting. An increase in pressure would help it in its contraction and hence we should expect a decrease in the melting point of ice as pressure on its surface is increased. *The melting point of ice decreases with the increase in pressure.*

For substances like wax, gold, silver etc. which expand on melting, an increase in pressure would make its expansion difficult. These substance have to be heated more in order to melt. As a result, we should expect an increase in the melting point, as pressure is increased. For such substances, *the melting point increases with the increase in pressure.*

### Impurities

Experiments show that *impurities decrease the melting point of a substance.* Though pure water freezes at 0 °C, salty water remain as water even at -1 °C. The extent to which the freezing point is lowered depends on the concentration of impurities dissolved into the liquid. For example when salt is added to ice, its melting point is reduced to a value as low as -10 °C. This method is used to defreeze roads in cold countries during winter. Antifreeze material is added to the water in the car radiators to stop water from freezing when temperature falls below 0 °C.

### Exercise 6.4

**For questions 1 - 3, select the appropriate response from the choices given.**

- Freon group of refrigerants are
 

<b>A.</b> Inflammable	<b>B.</b> Toxic
<b>C.</b> Non-inflammable and toxic	<b>D.</b> Nontoxic and non-inflammable
- In a refrigeration system, the expansion device is connected between the
 

<b>A.</b> Compressor and condenser	<b>B.</b> Condenser and receiver
<b>C.</b> Receiver and evaporator	<b>D.</b> Evaporator and compressor
- The bank of tubes at the back of domestic refrigerator is
 

<b>A.</b> Condenser tubes	<b>B.</b> Evaporator tubes
<b>C.</b> Refrigerant cooling tubes	<b>D.</b> Capillary tubes.

4. Explain the functions following parts in a refrigerator:
 

<b>(a)</b> Compressor	<b>(b)</b> Condensing coil
<b>(c)</b> Evaporating coil	<b>(d)</b> Thermostat
5. Why is it not advisable to put a refrigerator on a wall or near the wall?
6. Explain the following processes:
 

<b>(a)</b> Melting	<b>(b)</b> Solidification
--------------------	---------------------------
7. Using a sketch graph describe the process of heating a solid ice till it becomes water vapour.
8. Use the correct words from the following to answer questions that follows:  
*decreases, increases, heat, specific heat, insulator, condensation, entropy, internal energy.*
  - (a)** \_\_\_\_\_ is the process of changing from gas to liquid.
  - (b)** \_\_\_\_\_ is the measure of the average kinetic energy of the particles in a material.
  - (c)** When an object absorbs heat energy, its entropy \_\_\_\_\_.
  - (d)** \_\_\_\_\_ is the name for energy that is transferred only from a higher temperature to a lower temperature.
  - (e)** The measure of the amount of disorder in a system is called \_\_\_\_\_?

### Unit summary and new words

- Thermodynamics is the study of systems involving exchange of energy in the form of heat and work.
- An open system is a system that exchange both energy and matter with its surroundings.
- A closed system is a system that can exchange only energy with its surroundings, not matter.
- An isolated system is a system that cannot exchange either matter or energy with its surroundings.
- The internal energy of a system is identified with the random, disordered motion of molecules.
- The first law of thermodynamics states that the change in the internal energy ( $\Delta U$ ) of a system is equal to the sum of the heat ( $Q$ ) that flows across its boundaries and the work ( $W$ ) done on the system by the surroundings.

$$\Delta U = Q + W$$

- Entropy is the measure of a system's thermal energy per unit temperature that is not available to do useful work. Entropy is also a measure of the molecular disorder, or randomness of a system.
- The Second law of thermodynamic states that the spontaneous change for an irreversible process in an isolated system always proceeds in the direction of increasing entropy. In other words, the entropy of any isolated system always increases.

OR

'Heat flows spontaneously from a hotter object to a colder one, but not in the opposite direction; the reverse cannot happen without the addition of energy'.

- Melting is the change of state from a solid to a liquid. Melting of a pure substance occurs at a particular constant temperature called melting point.
- Solidification is the change of state from a liquid to a solid it is also known as freezing. A pure substance freezes at a temperature equal to its melting point

## Unit Test 6

**For questions 1 - 9, select the appropriate response from the choices given.**

- The laws of thermodynamics dictate the specifics for the movement of \_\_\_\_\_ and \_\_\_\_\_ within and across systems.
 

<b>A.</b> energy, motion	<b>B.</b> heat, work
<b>C.</b> light, heat	<b>D.</b> none of the above
- The mathematical representation to the first law of thermodynamics is \_\_\_\_\_.
 

<b>A.</b> $W + Q = U$	<b>B.</b> $Q = U + W$
<b>C.</b> $U = Q - W$	<b>D.</b> none of the above
- The first law of thermodynamics states that the total energy output is equal to the amount of heat supplied in a system. True or False?
 

<b>A.</b> True	<b>B.</b> False
----------------	-----------------
- Which of the following best illustrates the Second Law of Thermodynamics?
 

<b>A.</b> A cold frying pan heats up faster when placed in the microwave rather
---

than the stove

**B.** A hot frying pan cools down when it is taken off the kitchen stove.

5. The second law of thermodynamics states that energy \_\_\_\_\_ and disperses rather than staying concentrated.

**A.** spreads out

**B.** Stays

6. \_\_\_\_\_ is the change from liquid to solid.

**A.** boiling

**B.** melting

**C.** evaporation

**D.** freezing

7. "Absolute zero" is the bottom point on the \_\_\_\_\_ temperature scale.

**A.** Celsius

**B.** Kelvin

**C.** Fahrenheit

**D.** Zero

8. The following processes happen at the boiling point except \_\_\_\_\_.

**A.** change in density

**B.** change in state

**C.** gain in heat energy

**D.** change in temperature

9. Which of the following is the correct statement of the second law of thermodynamics?

**A.** There is a definite amount of mechanical energy, which can be obtained from a given quantity of heat energy.

**B.** It is impossible to transfer heat from a body at a lower temperature to a higher temperature, without the aid of an external source.

**C.** It is impossible to construct an engine working on a cyclic process, whose sole purpose is to convert heat energy into work.

**D.** All of the above.

10. State the first law of thermodynamics.

11. Describe the process of cooling a gas till it forms a solid.

12. A gas is enclosed in a metallic tube whose lid is a piston. Describe two ways of increasing the internal energy of the gas.

13. Entropy is defined as the randomness of a system. Give two examples to illustrate this.

14. Explain the term thermal equilibrium.

15. Distinguish between:

(a) Open and closed system.

- (b) Reversible and irreversible process. Give examples of each.
16. In a certain process, 600 J of work is done on the system which gives off 250 J of heat. What is the change in internal energy for the system?
17. How much work does a heat engine do if it takes in 2 500 J of heat and expels 1 500 J?
18. A hot solid of mass 100 g at 100° C is quickly transferred into 100 g of water in a container of mass 200 g at 20 °C. Calculate the resulting temperature of the mixture. (Specific heat capacity of the solid and the container is 400 J/kg K.
19. A gas enclosed in a cylinder occupies 0.030 m<sup>3</sup>. It is compressed under a constant pressure of  $3.5 \times 10^5$  Pa until its final volume is exactly one-third of its initial volume.
- (a) What was the change in the gas volume? \_\_\_\_\_
- (b) How much work was done? \_\_\_\_\_
- (c) The gas lost  $5.0 \times 10^3$  J as heat during the compression process. Did the internal energy of the gas increase or decrease? By how much? \_\_\_\_\_
20. A steel marble at room temperature was placed in a plastic-foam cup containing ice and water at 0 °C. After thermal equilibrium was reached, the temperature of the ice-water mixture and marble was 1 °C.
- (a) Which object lost heat energy?  
\_\_\_\_\_
- (b) Was any work done on the marble or by the ice?  
\_\_\_\_\_
- (c) Did the internal energy of the marble increase or decrease? What was a measurable effect of this change?  
\_\_\_\_\_
- (d) Did the internal energy of the water-ice mixture increase or decrease? How can this be observed?  
\_\_\_\_\_
- (e) Did the internal energy of the system consisting of the water-ice mixture and the marble increase or decrease?  
\_\_\_\_\_

# Introduction to Electromagnetic Induction

## Key Unit Competence

By the end of this unit the learner should be able to apply the principle of electromagnetic induction.

## Learning objectives

### Knowledge and understanding

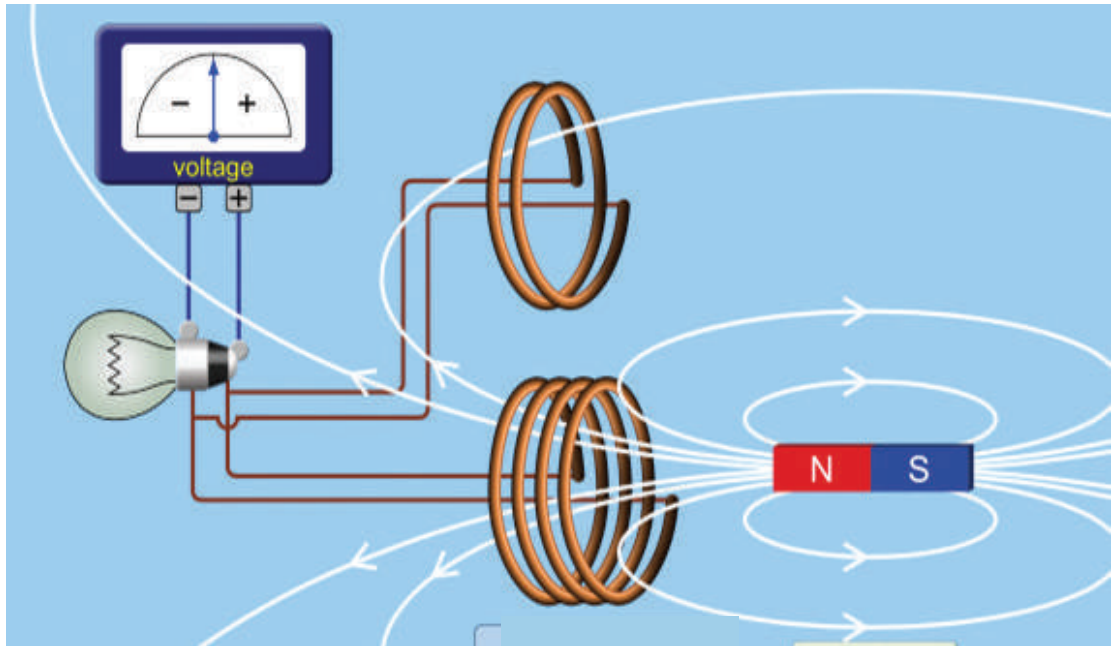
- State the Laws of electromagnetic induction.
- Recall the expression of induced EMF.
- Explain electromagnetic induction.
- Define the term alternating current.
- Explain EMF induced in a coil rotating in uniform magnetic field.
- Explain the functioning of alternating current generator.
- Explain the variation of induced EMF with change of generator frequency.
- Explain the functioning of a transformer
- Relate peak and RMS values.

### Skills

- Explain the expression of induced EMF in a straight conductor moving in magnetic field.
- Analyse induced EMF in a changing magnetic flux.
- Analyse applications of alternating current.
- Deduce an expression for induced EMF for a coil rotating in uniform magnetic field.
- Explain operation of basic alternating current generator.
- Evaluate variation in induced emf when generator frequency changes
- Relate peak and RMS values for sinusoidal currents.

### Attitude and value

- Appreciate the application of electromagnetic induction.
- Adapt or acquire scientific techniques, reasoning and attitudes for analyzing theories and expressions.
- Show the concern of possible risks involved in living and working near high- voltage power lines.



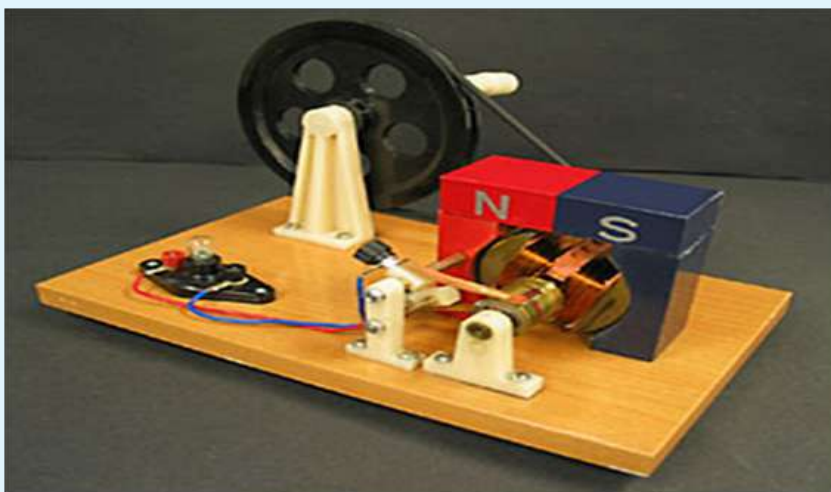
## Introduction

### Unit focus activity

#### Steps

##### Part 1

1. Physics student made the device shown in Fig. 7.1. What is the name of the device?



*Fig. 7.1: Picture of a device made by students*

2. Discuss what you think the student observed when the wheel was rotated.
3. Briefly describes the working principle of the device.

### Part 2

4. Study the picture in Fig. 7.2.
5. Have you seen the device in the picture before?  
Name it.
6. What is the function of the device?
7. Explain the working principle of the device.
8. Name the laws that govern the working principle of the devices in Figures 7.1 and 7.2.



Fig. 7.2: Picture of electronic device

In 1819, Hans Oersted discovered that whenever an electric current flows through a conductor, a magnetic field is produced around it. If such a conductor is placed in a magnetic field, it experiences a magnetic force (motor effect). Can the reverse effect hold true? That is, by moving a coil in a magnetic field, can an electric current be generated? This question was answered by Michael Faraday and Joseph Henry in the year 1831. The two scientists, although working independently, were able to show that an e.m.f can be generated. This method of generating e.m.f is called *electromagnetic induction*. The generated e.m.f is called *induced e.m.f* and hence induced electric current flows in a circuit. In this unit, we will discuss this concept and apply it in making some devices.

## 7.1 Demonstrations of electromagnetic induction

The induced e.m.f can be produced in two ways.

### (a) Relative movement (generator effect)

The following experiments will help us to understand electromagnetic induction.

#### Activity 7.1

#### To induce an electromotive force in a straight conductor (wire)

#### Materials

- U-shaped magnet
- Centre-zero galvanometer
- Copper wire (Conductor)



**Steps**

1. Connect a copper wire XY to a sensitive centre zero galvanometer (Fig. 7.3)  
Centre zero galvanometer

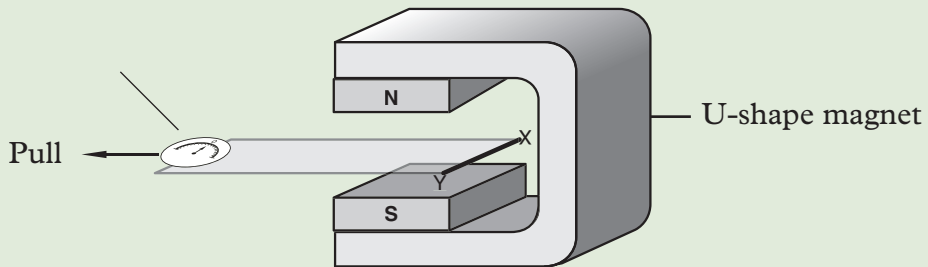


Fig. 7.3: A conductor in between the poles of a U-shaped magnet

2. Place a conductor in between the poles of a magnet as shown in Fig. 7.3 and observe the galvanometer reading when the wire is stationary.
3. Pull the conductor horizontally away from the poles and stop. Observe and explain what happens to the galvanometer pointer.
4. Re-introduce the wire in between the poles of the magnet and stop. Explain what happens to the galvanometer pointer.
5. Repeat the experiment, keeping the wire stationary and moving the magnet. Explain what happens to the galvanometer pointer.
6. Repeat the experiment by first moving the wire vertically up and down and then repeat by moving the magnet. Explain what happens to the galvanometer pointer.

Consider straight conductor XY connected to a galvanometer and placed in a magnetic field. When the wire is stationary, the pointer does not move. When the wire is being moved out, the pointer shows a deflection in one side (Fig. 7.4 (a)), but returns to the zero position once the wire stops (Fig. 7.4 (b)).

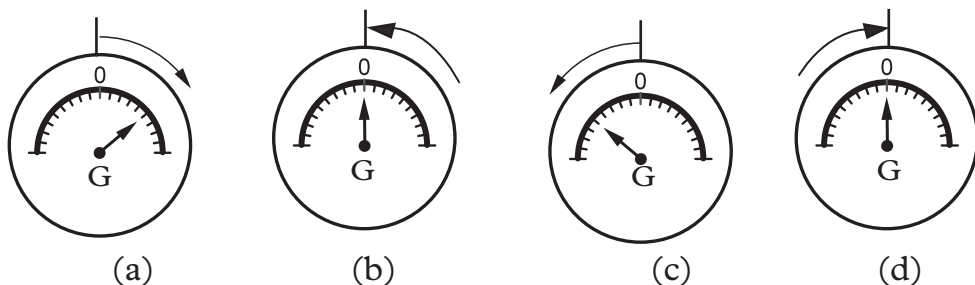


Fig. 7.4: Deflection on a galvanometer

When the conductor is re-introduced in between the poles, the pointer deflects but in the opposite direction (Fig. 7.4 (c)). However, when the conductor stops, the pointer once again returns to the zero position (Fig. 7.4 (d)).

Similar effects are observed when the magnet is moved instead of the conductor. However, no deflection is observed when the wire or the magnet is moved vertically up or down.

From this activity, we can conclude that whenever there is relative motion between a conductor and a magnet, an e.m.f is generated in the conductor. The generated e.m.f. is called **induced e.m.f.** If the conductor forms a part of circuit in Fig. 7.3 where it is connected to a galvanometer, the e.m.f. produces a current. The current produced is called **induced current**. This relative motion is such that the wire ‘cuts’ the magnetic field lines of force (Fig. 7.5).

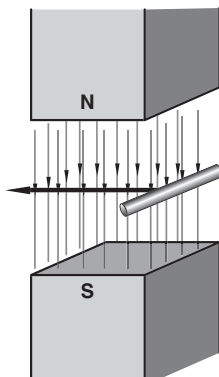


Fig. 7.5: A conductor cutting magnetic field lines of force

This phenomenon we are talking about is called **electromagnetic induction**.

### Activity 7.2

**To induce an electromotive force in a coil using a magnet.**

#### Materials

- Insulated copper wire
- Galvanometer
- Bar magnet
- Connecting wires

#### Steps

1. Make a coil using an insulated copper wire.
2. Connect the ends of the coil to a sensitive centre-zero galvanometer. Write down your observations.
3. Introduce a bar magnet into the coil and stop (Fig. 7.6).

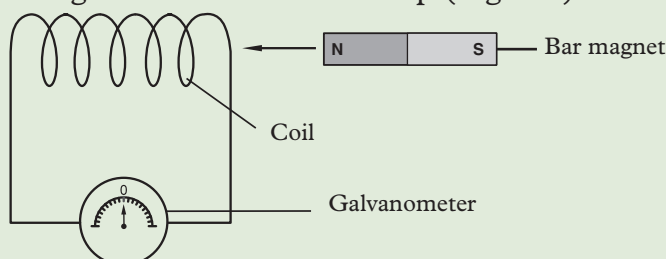


Fig. 7.6: Moving a magnet into a coil

4. Withdraw the magnet from the coil and stop. Write down your observations.
5. Repeat the experiment by moving the coil and keeping the magnet stationary. Observe and write down what happens to the pointer of the galvanometer in each case.
6. Move both the coil and the magnet in the same direction at the same speed. Observe and write down what happens to the pointer of the galvanometer?
7. Suggest explanations for all your observations in Steps 3 to 6.

When the magnet is introduced into the coil, the pointer of the galvanometer shows a deflection in one side but returns to the zero position when the magnet is brought to rest.

When the magnet is withdrawn from the coil, the pointer deflects but in the opposite direction. However, when the magnet stops, the pointer once again returns to the zero position.

Similar effects are observed when the coil moves instead of the magnet.

No deflection is observed when both the coil and the magnet are moved at the same speed in the same direction.

From this activity, we can conclude that an electromotive force is induced whenever there is relative motion between the coil and the magnet hence a current flows in the coil.

### (b) Changing a magnetic field (transformer effect)

#### Activity 7.3

#### To induce an electromotive force in a coil using another coil

##### Materials

- Insulated copper wire
- Connecting wires
- Galvanometer
- Source of current

##### Steps:

1. Make two coils using the insulated copper wire. Connect the coils as shown in Fig. 7.7. Keep the coils close together.

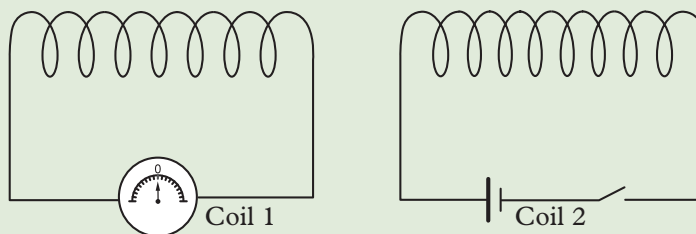


Fig. 7.7: Electromagnetic induction using two coils

2. Close the switch in coil 2. What happens to the pointer of the galvanometer? Explain.
3. Open the switch. Observe what happens to the galvanometer pointer. Explain your observation.

When the switch is closed, the pointer of the galvanometer momentarily deflects to one side but returns to the zero position when the switch is left closed. When the switch is opened, the pointer momentarily deflects again but in the opposite direction. However, when the switch is left open, the pointer once again returns to the zero position.

From this activity, we can conclude that an e.m.f is induced in coil 1 the moment the switch in coil 2 is closed or opened.

Electromagnetic induction is as a result of one of those actions-at-a-distance effects. Michael Faraday explained this action using a model based on magnetic field lines of force. He explained that an electromotive force is induced in a conductor which is a part of a closed loop or circuit when there is a change in the number of magnetic field lines (also known as the strength of magnetic field  $B$ ) passing through this loop or when the conductor 'cuts' the field lines.

Consider a coil moving away from a magnet as shown in Fig. 7.8.

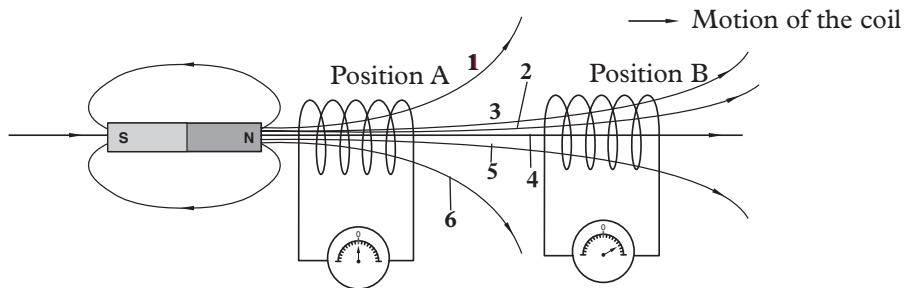


Fig. 7.8: Electromagnetic induction using a magnetic and a coil

The number of magnetic field lines linking or threading the coil decreases from 6 to 4 as the coil is moved from position A to position B. We can also say that the coil cuts two lines as it moves from position A to position B. Similar reasoning may be applied when the magnet is moved away or towards the coil.

In case of switching on and off of the circuit, the fields builds up to a certain strength and reduces to zero respectively as shown in Fig. 7.9.

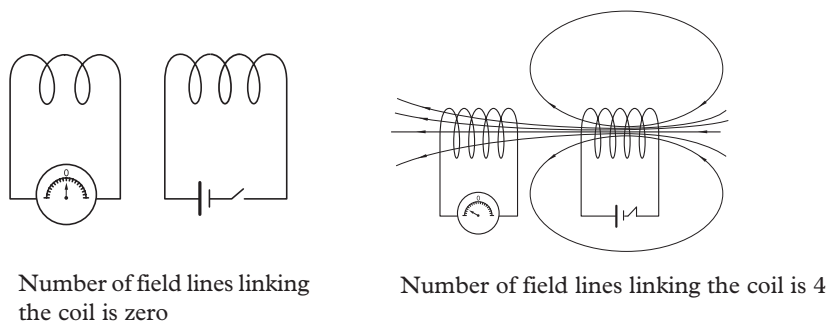


Fig. 7.9: Building the magnetic field

## 7.2 Factors affecting the magnitude of emf induced

The magnitude of the induced electromotive force depends on a number of factors. Before we discuss these factors, we recommend that you refresh your knowledge of quantities and measurements associated with magnetism that we have summarised in Appendix 1 at the end of this book.

The following experiments will help us to investigate what the magnitude of the induced e.m.f depends on.

### Activity 7.4

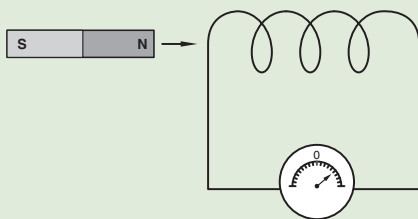
To investigate factors affecting the magnitude of the induced e.m.f. in a coil

#### Materials:

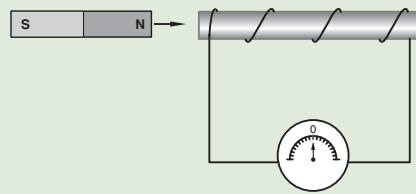
- Insulated copper wire
- Galvanometer
- Iron rod
- Bar magnet
- Connecting wires
- Ceramic magnet

#### Steps

1. Make a coil of a few turns using the insulated copper wire. Connect the coil to a centre-zero galvanometer.
2. Slowly introduce the magnet into the coil as shown in Fig. 7.10(a).



(a) Magnet moving slowly



(b) Magnet moving fast

Fig. 7.10: Moving a magnet into a coil at different speed

3. Repeat the activity by quickly introducing the magnet into the coil. Note and explain what happens to the pointer of the galvanometer.
4. Repeat the activity but wind the coil around a soft iron rod as shown on (Fig. 7.13(b)). What do you observe? Explain.
5. Repeat the activity using a coil with more turns. What do you observe? Explain.
6. Repeat the activity but use a stronger magnet e.g. ceramic magnets. What do you observe? Explain.

When the magnet is slowly introduced into a coil, the **induced e.m.f** ( $\epsilon$ ) is less than when the magnet is moved quickly. Same effect will be observed when the coil is moved slowly or quickly towards the magnet.

When a stronger magnet is used, the induced electromotive force increases, . When a coil with more turns is used, the induced emf is found to increase. The induced electromotive force is found to increase when a soft iron core is used.

Fig. 7.11 (a) shows one line of force linking the coils while in (b) there are three lines of force. The soft iron core concentrates the flux lines onto the coil producing a higher rate of change of flux when there is relative movement.

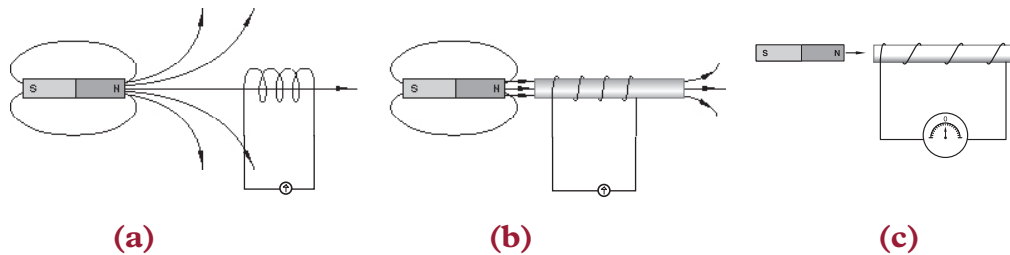


Fig. 7.11: Inducing an e.m.f using a coil wound on a soft iron core

We can conclude that, *the magnitude of the induced emf is directly proportional to:*

- the strength of magnetic field i.e the stronger the magnet the higher the induced emf.
- the number of turns in the coil i.e. the more turns the higher the induced emf.
- the induced emf is much higher in the presence of a soft iron core.
- Area of the coil.
- The rate (speed) of cutting the magnetic flux.

### 7.3 Laws of electromagnetic induction

#### Activity 7.5

To state the laws of electromagnetic induction

#### Materials

- Magnet
- Insulated copper wire
- Centre-zero-galvanometer
- Connecting wires

#### Steps

1. Revisit activity 7.4, change the motion of the magnet in the coil; start slowly then increase the speed. What do you observe on the pointer?
2. Now explain, how the rate of change of magnetic flux relates to the electromotive force (e.m.f.) induced.
3. Conduct a research from the internet and reference books on the laws of electromagnetic induction.

### 7.3.1 Lenz's law

When an electromotive force is induced in a circuit, a current flows in the circuit. What is the direction of the induced current?

Consider a magnet moving towards or away from a coil as shown in Fig. 7.12 (a) and (b).

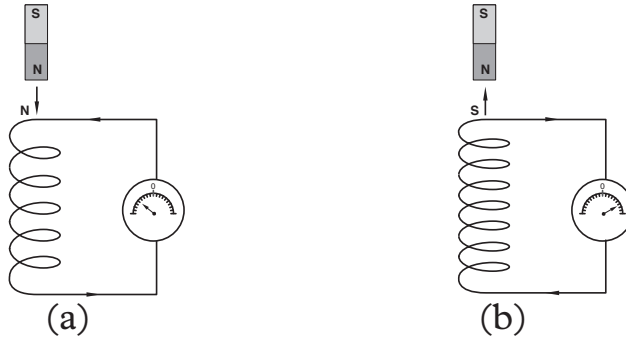


Fig. 7.12: Direction of the induced electromotive force

When a north pole is moved towards a coil, the current flows in such a way as to oppose the introduction of the north pole. A north pole (N) is therefore induced at the top end of the coil to repel the incoming north pole of the magnet. Similarly a south pole is induced at the top end of the coil to resist the withdrawal of north pole of the magnet.

The direction of the induced current can be determined using a law that was developed by a German scientist called Lenz.

Lenz's law states that *the direction of the induced current is such that it opposes the change producing it.*

### 7.3.2 Fleming's right hand rule

In case of straight conductors moving in a magnetic field, Fleming's right hand rule gives the relationships between the directions of the field motion and induced current.

It states that,

*If the thumb and first two fingers of the right hand are mutually perpendicular to each other, the **F**irst finger pointing in the direction of the **F**ield and the **th**uMb in the direction of **M**otion of the conductor, then the **se**Cond finger points in the direction of the induced **C**urrent see Fig. 7.13.*

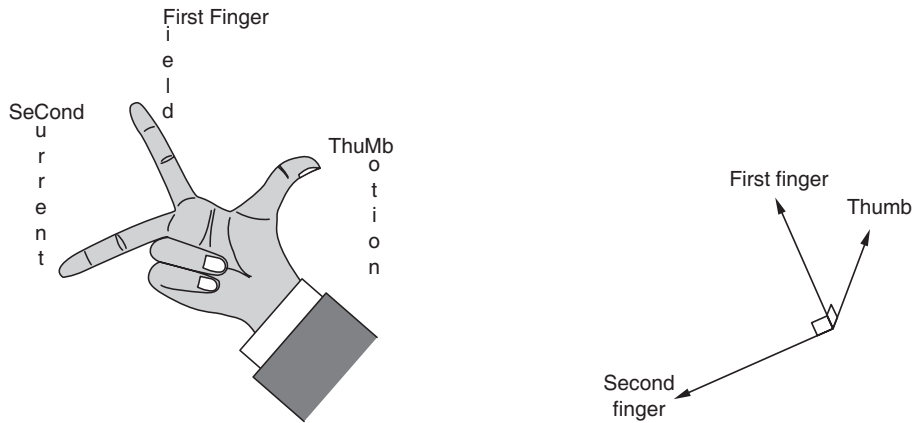


Fig. 7.13: Fleming's right hand rule

### 7.3.3 Faraday's law

#### 7.3.3.1 Definition of terms

**Magnetic flux ( $\Phi$ ):** is a measure of the quantity of magnetism, being the total number of magnetic lines of force passing through a specified area in a magnetic field. It represents the strength of the magnetic field over a given area. The SI unit is **weber** (symbol **Wb**).

**Magnetic flux density (**B**)** is the amount of magnetic flux through a unit area taken perpendicular to the direction of the magnetic flux, It is a vector quantity. Its SI unit is **tesla** (symbol **T**), or **N/(A·m)** expressed in SI base unit.

Magnetic flux through a close wire loop is the product of the magnetic flux density and the area (**A**) of the loop.

Let us consider three cases of orientation of the place of the loop (**A**) in relation to the direction of the magnetic field (**B**) .

Let:

#### Case 1

The loop of coil perpendicular to the magnetic field (Fig. 7.14)

i.e  $\vec{B}$  and  $\vec{A}$  (normal to loop) are parallel  
hence the angle between **B** and **A** is  $0^\circ$

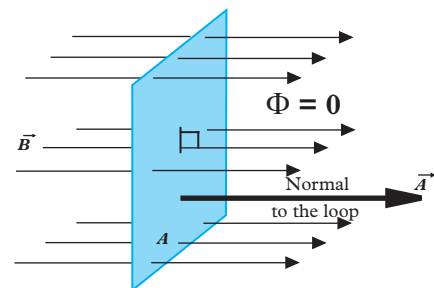


Fig. 7.14

$$\Phi_1 = B \times A \cos 0^\circ = BA$$



**Case 2**

The loop of the coil inclined at an angle to the magnetic field (Fig. 7.15)

i.e Angle between  $\vec{B}$  and  $\vec{A}$  is  $\theta$

$$\Phi_2 = B \times A \cos\theta$$

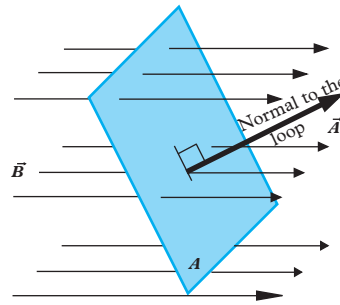


Fig. 7.15

**Case 3**

The loop of the coil parallel to the magnetic field (Fig. 7.16)

i.e  $\vec{B}$  and normal  $\vec{A}$  are at  $90^\circ$

$$\Phi_3 = B \times A \cos 90^\circ = 0$$

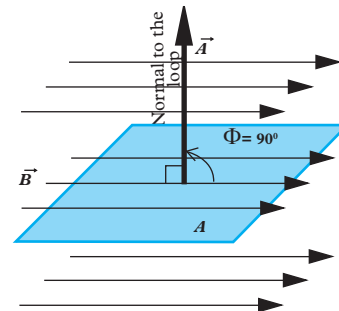


Fig. 7.16

**7.3.3. Statement of Faraday's law**

The factors affecting the magnitude of the induced electromotive force were summarised by Michael Faraday in what is known as **Faraday's law of electromagnetic induction**.

The law states that; *the electromotive force induced in a conductor is directly proportional to the rate at of change of the magnetic flux linked to the conductor*

$$\varepsilon \propto - \frac{\Phi}{t} \Rightarrow \varepsilon = - \frac{\Phi}{t} \quad (\text{since the constant } k = 1)$$

In case the conductor has N turns,

$$\varepsilon = - \frac{N \Phi}{t}$$

**Example 7.1**

A small piece of metal wire is dragged across the gap between the pole pieces of a magnet in 0.5 second. The magnetic flux between the pole pieces is known to be  $8 \times 10^{-4}$  Wb. Calculate the emf induced in the wire.

**Solution**

The magnetic flux threading the coil has changed from 0 to  $8 \times 10^{-4} \text{ Wb}$  in 0.5 s

$$\varepsilon = \frac{\Phi}{t} = \frac{8 \times 10^{-4}}{0.5} \text{ V} = 1.6 \times 10^{-3} \text{ V} = 1.6 \text{ mV}$$

**Example 7.2**

Calculate the emf induced in a 250 turn coil with a cross-section of  $0.18 \text{ m}^2$  if the magnetic field through the coil changes from  $0.10 \text{ Wb m}^{-3}$  to  $0.60 \text{ Wb m}^{-3}$  at a uniform rate over a period of 0.02 second.

**Solution**

$E = ?$ ,  $N = 250$ ,  $A = 0.18 \text{ m}^2$ ,  $B_1 = 0.10 \text{ Wb m}^{-1}$ ,  $B_2 = 0.60 \text{ Wb m}^{-2}$ ,  $t = 0.02 \text{ s}$

The magnetic flux is changing due to change in  $B$  since  $A$  is constant.

Rate of change of magnetic flux,

$$\frac{\Phi}{t} = \frac{NA (B_2 - B_1)}{t} = \frac{250 \times 0.18(0.60 - 0.10)}{0.02} \text{ V}$$

$$= 1125 \text{ V}$$

$$E = \frac{\Phi}{t} = -1125 \text{ V}$$

**Exercise 7.1**

- Describe an experiment to illustrate electromagnetic induction.
- State the two laws of electromagnetic induction.
- Describe an experiment to demonstrate Faraday's law of electromagnetic induction.
- A long bar magnet is pushed into a coil with many turns as shown in Fig. 7.17.

(a) What happens to the needle of the centre-zero-galvanometer when the magnet;

- slowly enters the coil,
- remains at rest inside the coil,
- is rapidly withdrawn.

(b) Explain

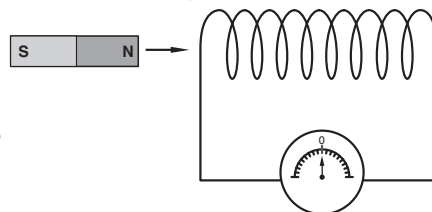


Fig. 7.17: Bar magnet pushed into the coil

- (i) why the magnet has to be long.  
 (ii) why the coil has to have many turns.
5. Explain the following terms:  
 (a) Electromagnetic induction.                      (b) Induced electromotive force.  
 (c) Induced current.
6. Explain how to determine the direction of the induced current in a coil, when a magnet moves into the coil.
7. Describe energy conversions during the process of electromagnetic induction in:  
 (a) A coil using a bar magnet.  
 (b) A coil using another coil carrying a current.
8. Two coils are placed near each other as shown in Fig. 7.18.

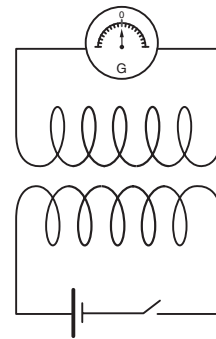


Fig. 7.18: Two coil near each other

- (a) What happens to the needle of the galvanometer  
 (i) On closing the switch?  
 (ii) If the switch is kept closed?  
 (iii) On opening the switch?
- (b) Give three possible ways of increasing the deflection in the galvanometer
9. A wire cuts across a flux of  $0.2 \times 10^{-2}$  Wb in 0.12 second. What is the magnitude of emf induced in the wire?
10. A conducting circular loop having a radius of 5.0 cm, is placed perpendicular to a magnetic field of 0.50 T. It is removed from the field in 0.50 s. Find the average emf produced in the loop during this time.
11. A coil of area  $0.15 \text{ m}^2$  and 100 turns is placed perpendicular to a magnetic field. The field changes from  $5 \times 10^{-3} \text{ Wb m}^{-2}$  to  $2 \times 10^{-3} \text{ Wb m}^{-2}$  in a time interval of 30 ms. Calculate the emf induced in the coil.

## 7.4 E.m.f induced in a straight conductor moving in a straight field

### Activity 7.6

To determine the magnitude of induced e.m.f in a straight conductor

#### Materials

- Permanent magnets
- Conductor
- Galvanometer
- Connecting wires

**Steps**

1. Slowly move the conductor to or away from the magnet observe what happens to the galvanometer.
2. Repeat the experiment but move the conductor quickly to or away from the magnet.
3. Slowly move the magnet away or towards conductor. Observe what happens to the galvanometer.
4. Repeat Step 3 by uniformly moving the magnet instead of moving the conductor.
5. Reduce the length of the conductor in the magnetic field, and repeat the experiment. What do you observe
6. Repeat step 1 but use a strong magnetic field. What do you observe? Comment.
7. Repeat the activity but tilt the conductor such that it makes angle  $\Phi$  to that field.

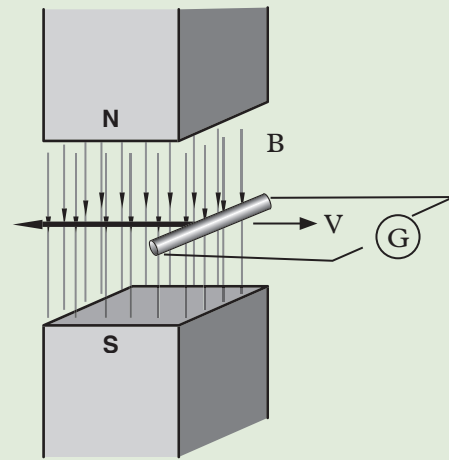


Fig. 7.19: A conductor cutting magnetic field lines of force

Consider a straight conductor of length  $l$  being moved through a magnetic field of flux density  $B$  with a velocity  $v$  (Fig. 7.20). Since the conductor cuts the magnetic field, an e.m.f. is induced into it.

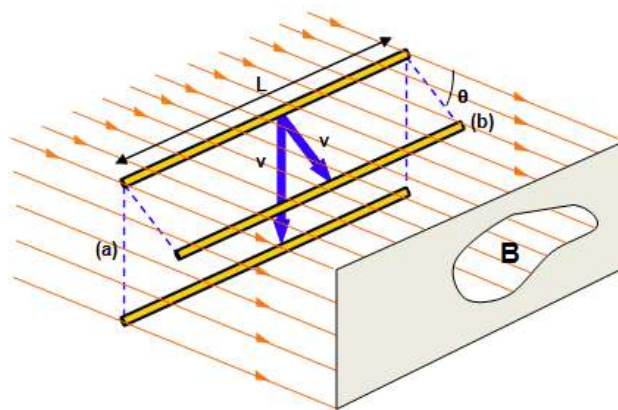


Fig. 20: Straight conductor moving in magnetic field

(a) When the conductor is moving perpendicular to the magnetic field, it cuts the magnetic field at right angles. It sweeps through an area  $A = vl$  every second in the magnetic (see the vertical plane (a) in Fig 7.20). In other words, its rate of change of area with time is  $\frac{A}{t} = lv$

$$\text{From Faraday's law, } \varepsilon = \frac{\Phi}{t} = \frac{BA}{t} = B \times \frac{A}{t} = Blv$$

In short, the induced emf in the conductor  $\varepsilon = Blv$

(b) When the conductor cuts through the magnetic flux at an angle  $\theta$  (see the slanting plane (b) in Fig 7.20), where  $\theta$  is the angle between the magnetic field and the direction of motion, the induced emf is becomes

$$\varepsilon = Blv \sin \theta$$

If the conductor has  $N$  turns, then the induced emf is given by

$$\varepsilon = NBlv \sin \theta$$

From this equation, we can see that maximum e.m.f is induced when the conductor moves at right angles to the field. ( i.e  $\theta = 90^\circ$  hence  $\sin \theta = \sin 90^\circ = 1$ ).

### Example 7.3

If a 8 m long metallic bar moves in a direction  $30^\circ$  to the magnetic field with a speed of  $5 \text{ m s}^{-1}$ , 20 V emf is induced in it. Find the value of magnetic field intensity.

#### Solution

$$\varepsilon = Blv \sin \theta \text{ or } B = \frac{\varepsilon}{lv \sin \theta} \text{ or } B = \frac{20}{8 \times 5 \times \sin 30^\circ} \text{ T} = 1 \text{ T}$$

### Example 7.4

A wire of length 80 cm moves with a speed  $20 \text{ m s}^{-1}$  perpendicular to a magnetic field of induction  $0.2 \text{ Wb m}^{-2}$ . Calculate the magnitude emf induced in the wire.

#### Solution

$$l = 80 \times 10^{-2} \text{ m, } v = 20 \text{ ms}^{-1}, B = 0.2 \text{ Wb m}^{-2}$$

$$\varepsilon = Blv = 0.2 \times 80 \times 10^{-2} \times 20 \text{ V} = 3.2 \text{ V}$$

## 7.5 E.m.f induced in a coil rotating in uniform magnetic field

### Activity 7.7

To investigate the emf produced in a rotating coil in a uniform magnetic field

#### Materials

- A coil
- Two-permanent magnets
- Centre-zero galvanometer
- Connecting wire

#### Steps

1. Connect a centre-zero galvanometer to the coil using connecting wire to form a closed loop.
2. Place two opposite sides (N-S) of the permanent magnet close to each other.
3. Move the coil in between the magnet, first vertically then horizontally. Observe the deflection of the pointer each time. Comment on your observations.
4. Now move the coil diagonally and observe the changes (if any) on the pointer of galvanometer. Comment on your observation.
5. Deduce how the area of the coil and magnetic field are related.

Consider a rectangular coil  $abcd$  rotating at linear velocity  $v$  m/s in a uniform magnetic field  $B$  (Fig. 7.21).

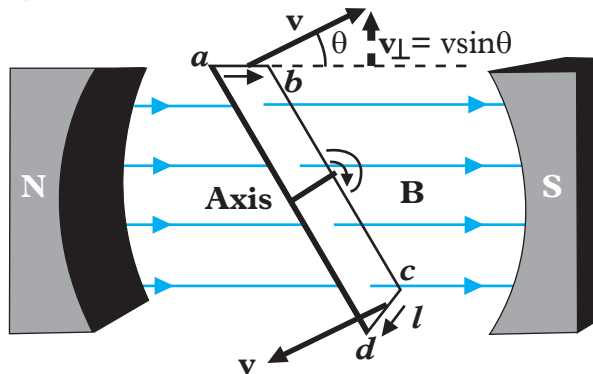


Fig. 7.21: A coil rotating in a magnetic field

Since it keeps on changing position during the rotation, the component of  $v$  that is perpendicular to the magnetic field  $B$  at any position is  $v \sin\theta$ .

From Faraday's law, the emf induced in a straight conductor at any position inside a magnetic field is given by

$$\varepsilon = -Blv\sin\theta$$

Therefore, in the side  $ab$  of the coil, an emf of  $\varepsilon = -Blv\sin\theta$  is induced.

Similarly, in the side  $cd$  of the coil, an emf of  $\varepsilon = -Blv\sin\theta$  is induced, in a direction opposite to that in  $ab$ .

Therefore, the total emf induced in the coil is  $\varepsilon = -2Blv\sin\theta$ .

From this expression, we can see that

- (a) Maximum emf is induced in the coil when the coil is horizontal, i.e, when the angle between  $\mathbf{v}$  and  $\mathbf{B}$  is  $90^\circ$  (since  $\sin 90^\circ = 1$ ). See Fig. 7.22 (a).  
 (b) Minimum emf is induced in the coil when the coil is vertical, i.e, when the angle between  $\mathbf{v}$  and  $\mathbf{B}$  is  $0^\circ$  (since  $\sin 0^\circ = 0$ ). See Fig. 7.22 (b).

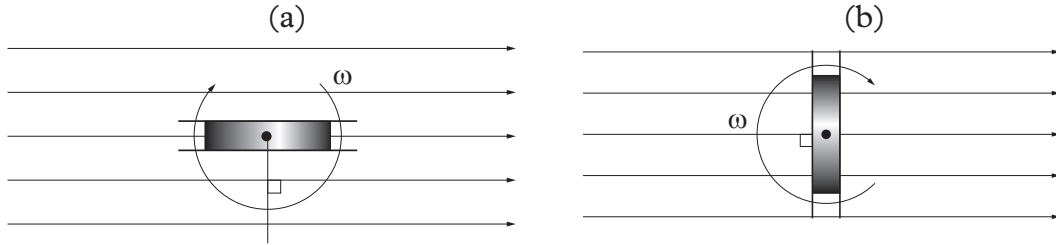


Fig. 7.22: Horizontal and vertical positions of the rotating coil

We can express the induced emf in the coil i.e  $\varepsilon = -2Blv\sin\theta$  in terms of angular velocity ( $\omega$ ) of the coil as follows.

From our knowledge of circular motion ( see the appendix at the end of book).

$$\text{Angular velocity of the coil } \omega = \frac{\text{angular displacement } (\theta)}{\text{time taken } (t)}$$

$$\text{In symbols } \omega = \frac{\theta}{t} \quad \Rightarrow \quad \theta = \omega t$$

$$\text{In addition, linear velocity } v = \frac{\text{angular velocity } (\omega)}{\text{radius of circular path of rotation } (r)}$$

$$\text{In symbols } v = \omega r \text{ But from the coil dimensions, } r = \frac{ad}{2}$$

$$\Rightarrow v = \omega r = \frac{\omega ad}{2}$$

The length  $l$  of the coil in this case is  $l = ab$

Substituting for  $l$ ,  $v$  and  $\theta$  in the expression  $\varepsilon = -2Blv\sin\theta$  we get

$$\varepsilon = 2Blv\sin\theta = 2Bab \frac{\omega ad}{2} \sin \omega t$$

Since  $ab \times ad = A$  (area of coil), the equation simplifies to

$$\varepsilon = -BA\omega \sin \omega t$$

If the coil has  $N$  number of turns the induced emf is given by

$$\varepsilon = -NBA\omega \sin \omega t$$

Remember the negative sign is in accordance to lenz's law.

Since  $\varepsilon_0 = -NBA\omega$  (the peak or maximum value of induced emf)

Then we can write the general expression of induced emf at any position as

$$\varepsilon = \varepsilon_0 \sin \omega t$$

The graph of induced emf against time is a sine wave, shown in the Figure 7.23.

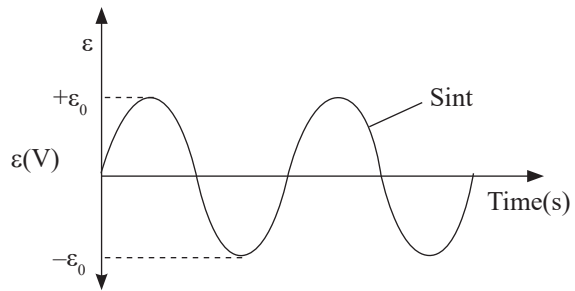


Fig. 7.23: Graph of emf induced against time

The current also follows producing a graph of the same shape as shown in fig. 7.24.

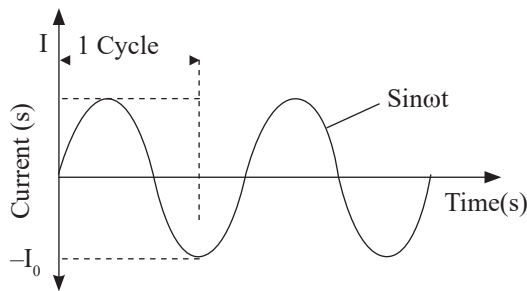


Fig. 7.24: Graph of current induced against time

$$I = I_0 \sin \omega t$$

The emf (hence current) is therefore an alternating one (a.c) which varies sinusoidally with time i.e reverses direction at regular intervals, having a magnitude that varies continuously in sinusoidal manner.

The emf is periodic i.e it continually repeats the same pattern in time with period,

$$T = \frac{1}{f}$$

Therefore since  $\omega = 2\pi f$ , where  $f$  is the frequency of the rotation of the coil the induced emf is also given by  $\varepsilon = \varepsilon_0 \sin (2\pi f t)$ .

### Example 7.5

A generator with a circular coil of 80 turns of area  $3.0 \times 10^{-2} \text{ m}^2$  is immersed in a 0.20 T magnetic field and rotated with a frequency of 50 Hz. Find the maximum emf which is produced during a cycle.

### Solution

The maximum emf for a generator is

$$\varepsilon = NBA\omega$$



We Know

$$N = 80, A = 3.0 \times 10^{-2} \text{ m}^2, B = 0.20 \text{ T and } f = 50 \text{ Hz}$$

$$\text{Since } \omega = 2\pi f = 2\pi(50) = 314 \text{ radians/s}$$

$$\varepsilon_0 = (80)(3.0 \times 10^{-2})(0.20)(314) = 150.72 \text{ V}$$

### Exercise 7.2

- Write down an expression for the emf induced between the ends of a rod of length,  $l$  moving with velocity  $v$  so as to cut a magnetic field of flux density  $B$  normally.
- A straight wire of length 60 cm and resistance  $8 \Omega$  moves sideways with a velocity of 20 m/s at right angles to a uniform magnetic field of flux density  $2.0 \times 10^{-3} \text{ T}$ . Find the current that would flow if its ends were connected by leads of negligible resistance.
- A rectangular coil 35.0 cm long and 20.0 cm wide of 30 turns rotates at uniform rate of 3000 rev/min about an axis parallel to its long side to a uniform magnetic field of flux density  $5.00 \times 10^{-8} \text{ T}$ .

Determine

- The frequency of induced emf
  - The maximum value of induced emf
- The emf induced by an a.c generator is given by  $\varepsilon = \varepsilon_0 \sin \omega t$ 
    - Explain the meaning of each symbol used.
    - Give the units for the symbols used.
    - Draw diagram showing the position of the coil and magnetic field the
      - $t = 0$
      - $\varepsilon = \varepsilon_0$
  - The Fig. 7.25 shows the instantaneous position of a rotating loop of wire between two bar magnets. The loop is rotating clockwise when viewed from P. The magnets and the loop all lie in the same plane. Copy and indicate the direction of induced current flow in the loop.

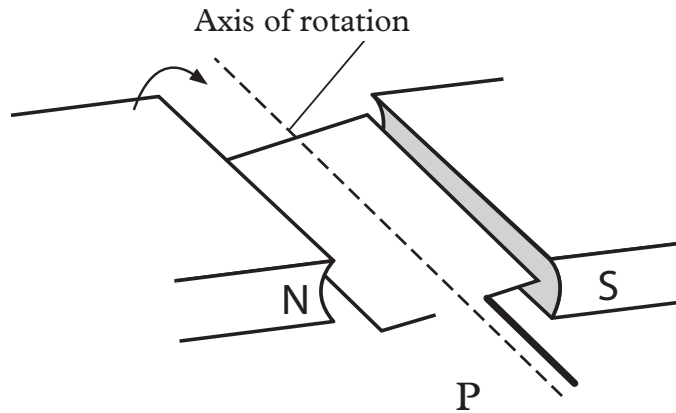


Fig. 7.25: Rotating loop of wire between magnets

- (b) The electromagnetic induction can be summarized by two laws namely: Faraday's and Lenz's laws of electromagnetic induction. State the laws.
6. A wire of length 0.1 m moves with a speed of  $10 \text{ m s}^{-1}$  perpendicular to a magnetic field of induction  $1 \text{ Wb m}^{-2}$ . Calculate the induced emf.
  7. A straight conductor 1 m long moves at right angles to both its length and a uniform magnetic field. If the speed of the conductor is  $2 \text{ m s}^{-1}$  and the strength of the magnetic field is 1 T, find the value of induced emf in volt.
  8. A horizontal straight wire 10 m long extending east and west is falling with a speed of  $5.0 \text{ m s}^{-1}$  at right angles to the horizontal component of the earth's magnetic field  $0.30 \times 10^{-4} \text{ Wb m}^{-2}$ . Calculate the emf in the wire.
  9. An air plane with 20 m wing spread is flying at  $250 \text{ m s}^{-1}$  straight south parallel to the earth's surface. The earth's magnetic field has a horizontal component of  $2 \times 10^{-5} \text{ Wb m}^{-2}$  and the dip angle is  $60^\circ$ . Calculate the induced emf between the plane tips.
  10. A rectangular coil of 100 turns has dimensions of 10 cm by 15 cm. It rotates about an axis through the midpoint of the short sides. The axis of rotation is perpendicular to the direction of the magnetic field of strength 0.50 T, and it is rotating at 600 rpm.
    - (a) When is the emf induced in the coil a maximum?
    - (b) Is the induced emf ever zero? If so, when?
    - (c) What is the maximum induced emf?

## 7.6 Alternating current (a.c) generator

### Activity 7.8

To observe and describe the working of an a.c generator

#### Materials

- Model of a.c generator
- Manila paper

#### Steps

1. With the help of a model provided by your teacher, describe the working of an a.c generator. Illustrate the working on a manila paper.
2. Present your description to the rest of the class during the class discussion.

### 7.6.1 Structure of a simple a.c generator

Fig. 7.26 shows a diagram of a simple a.c generator.

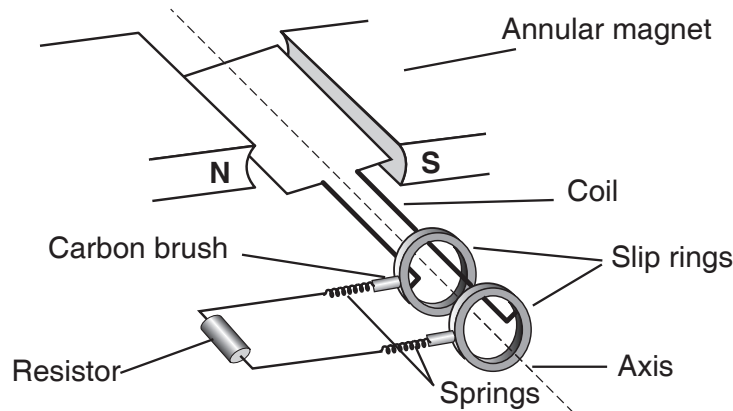


Fig. 7.26: A simple ac generator

The generator consists of a rectangular coil of conductor wire whose ends are connected to two slip rings. The slip rings make contact with carbon brushes which connect them to an external circuit. Two light springs are used to make the carbon brush press lightly on the slip rings thus making a good contact between the carbon brushes and the slip rings. The coil is placed in between two poles of a permanent magnet. The poles are annular in shape so as to concentrate the magnetic field lines on the coil.

### 7.6.2 Working of simple a.c generator

When the coil is rotated about its axis, an electromotive force is induced depending on the position of the coil. Let us start with the coil in a vertical position as shown

in Fig. 7.27 (a). In this vertical position the wires  $XY$  and  $WZ$  are moving along the magnetic field lines. The wires are therefore not cutting the magnetic field lines resulting in no electromotive force being produced (Fig. 7.27(a)). As the coil is rotated from this position, it starts to cut across the magnetic field lines of force and an electromotive force is induced (Fig. 7.27 (b)). During the first quarter of rotation, the induced e.m.f increases from zero to a **maximum value (peak value)** when the coil becomes horizontal (Fig. 7.27(c)). During the second quarter of rotation the induced electromotive force reduces and reaches zero again when the coil is in vertical position (Fig. 7.27(d)).

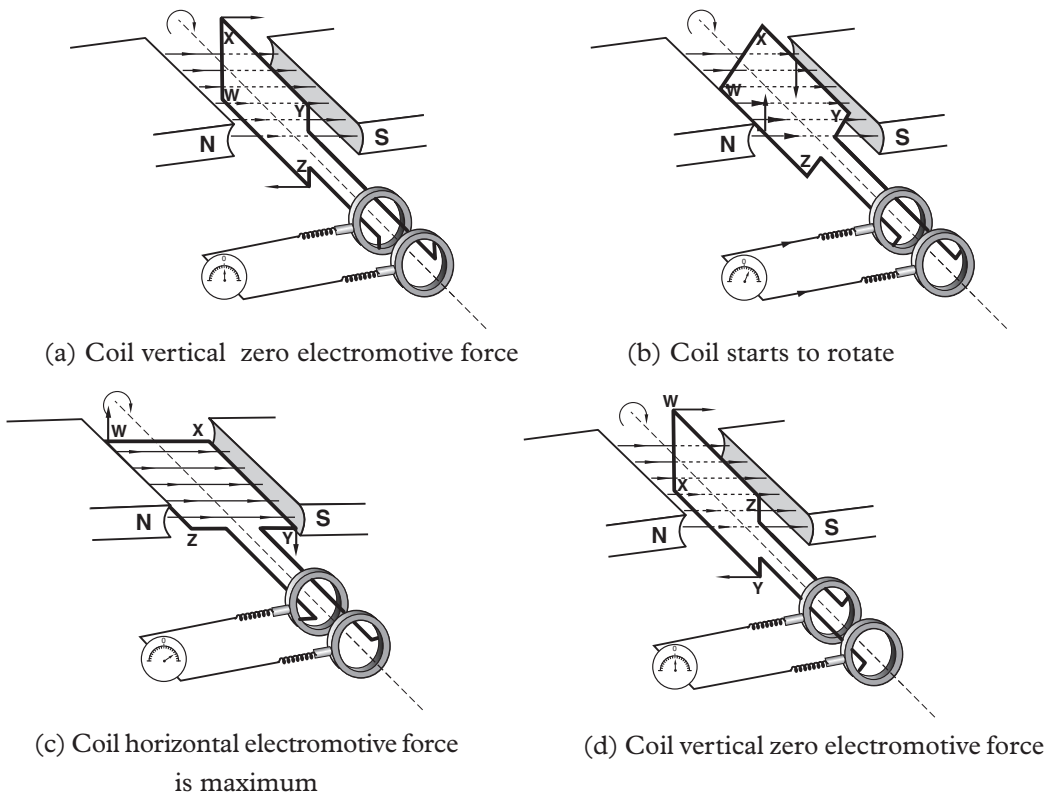


Fig. 7.27: Working of a simple generator

The induced e.m.f sets up a potential difference between the ends of the coil which are connected to the two slip rings mounted on the axle on which the coil rotates. This potential difference drives the current in the external circuit. This process is repeated in the third and fourth quarter of rotation. However, the direction of the current in the coil changes. The direction of the induced current can be determined by Fleming's right hand rule. In the first half of rotation the side  $XY$  is moving down. The current therefore flows from  $X$  to  $Y$  and from  $Z$  to  $W$ . During the second half of rotation,  $XY$  is moving up and so the current flows from  $Y$  to  $X$  and from  $W$  to  $Z$  (Fig. 7.28).

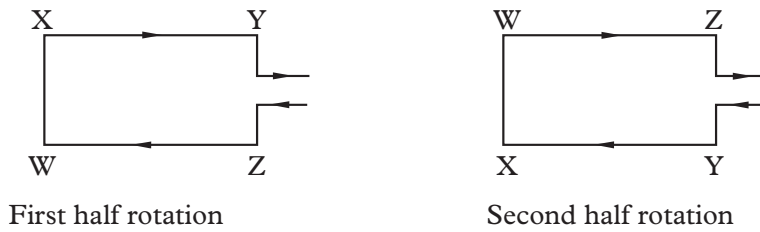


Fig. 7.28: Set-up showing the rotation of coil

The current changes direction after every half a rotation (cycle). Fig. 7.29 shows how the current in the external circuit changes with the position of the coil. The coil produces an electromotive force that changes in a manner similar to a sine curve.

This shows that the cutting of the magnetic lines of force is greatest whenever the coil passes through its horizontal position. In this position, the induced electromotive force is maximum. The current flows in the circuit, first in one direction and then in the opposite direction. A current that flows back and forth in a circuit is called an *alternating current*. The number of cycles it completes in one second is known as the *frequency of the alternating current* and is measured in hertz (Hz).

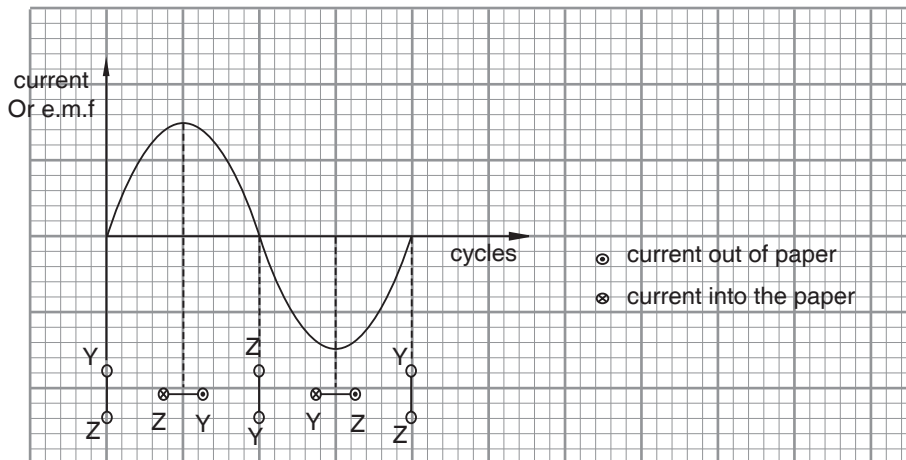


Fig. 7.29: Variation of current or e.m.f. with coil positions

## 7.7 Root-mean-square (r.m.s) value

The value of an alternating current (and emf) varies periodically with time in magnitude (size) and direction. The problem then becomes "which value should we use to measure it?"

**Activity 7.9****To deduce an expression for root mean square current****Material**

- An ammeter 1 A
- A resistor 10  $\Omega$
- A switch which selects between two connections
- Mains power supply 2 V, 50 Hz.
- d.c. power supply 3 V
- A bulb 2.5 V, 0.3 A

**Steps**

1. Connect the circuit as shown in Fig. 7.30.

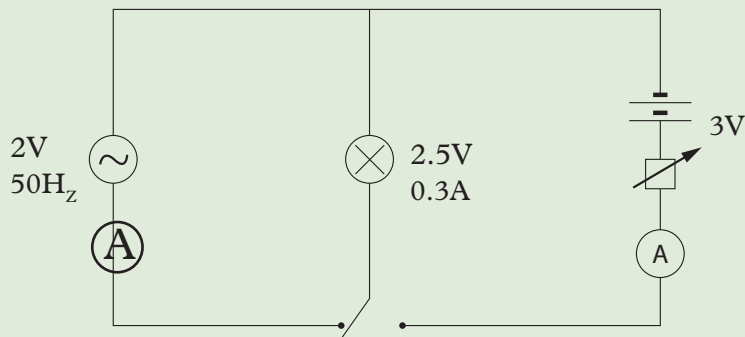


Fig. 7.30: Set-up to determine root-mean-square

2. First switch on the a.c. circuit and note the brightness of the lamp.
3. Secondly switch on the d.c. circuit.
4. Adjust the currents such that the brightness is the same as when the a.c. circuit was switched on i.e. the bulb is fully lit
5. Record the value of the d.c. current that produces the same brightness as the a.c. current.

Since the lamp is fully lit by a d.c current of 0.3 A, the equivalent value of a.c. is 0.3 A a value called **root-mean-square value** (r.m.s).

The **r.m.s** value of an alternating current is **the steady direct current which converts electrical energy to other forms of energy in a given resistor at the same rate as the a.c.**

Consider energy in d.c and a.c circuit

$$\text{Power } I_{\text{d.c}}^2 R = \text{mean value } I_{\text{a.c}}^2 \times R$$

$$I_{d.c} = \sqrt{\text{mean value of } I_{a.c}^2}$$

= square root of the mean value of the square of a.c the current

$$I_{d.c} = I_{a.c} = I_{r.m.s}$$

If the a.c. is sinusoidal, then

$$I = I_0 \sin \omega t \quad \text{Where, } I_0 = \text{peak value of a.c}$$

$$\therefore I_{r.m.s} = \sqrt{\text{mean value } I_0^2 \sin^2 \omega t}$$

$$= I_0 \sqrt{\text{mean value } \sin^2 \omega t}$$

The graph of  $\sin \omega t$  and  $\sin^2 \omega t$  is as shown in Fig. 7.31

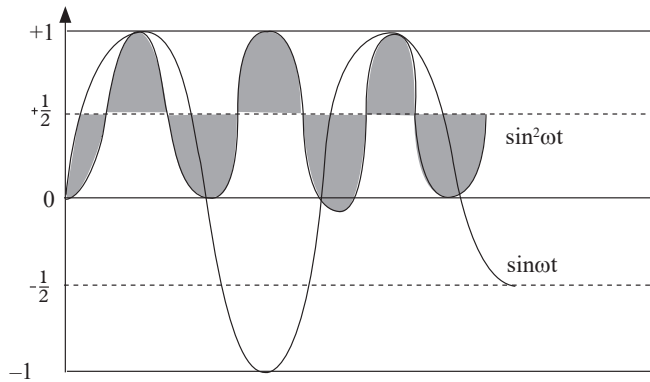


Fig. 7.31: The sinusoidal graph of  $\sin \omega t$  and  $\sin^2 \omega t$

The value of  $\sin^2 \omega t = \frac{1}{2}$

$$\text{Therefore, } I_{r.m.s} = \sqrt{\frac{I_0^2}{2}}$$

$$\text{Hence, } I_{r.m.s} = \frac{I_0}{\sqrt{2}} = 0.707 I_0$$

The same relationship is used for e.m.f and p.d.s, that is

$$\varepsilon_{r.m.s} = 0.707 \varepsilon_0$$

$$V_{r.m.s} = 0.707 V_0, \text{ where, } \varepsilon_0 = \text{Peak emf}$$

$$V_0 = \text{Peak voltage}$$

In a.c circuit the r.m.s value is the one that is usually quoted. Thus a power source of 240V is the r.m.s value.

**Example 7.6**

The power source of a house is 240 V. Find the peak value.

**Solution**

$$\varepsilon_0 = 240 \text{ V}$$

$$\varepsilon_{\text{r.m.s}} = 0.707\varepsilon_0$$

$$\varepsilon_0 = \frac{\varepsilon_{\text{r.m.s}}}{0.707} = \frac{240 \text{ V}}{0.707} = 339 \text{ V}$$



**Note:** a.c voltmeters and ammeters are calibrated to read r.m.s value.

**Exercise 7.3**

- An a.c circuit has an r.m.s current of 7.0 A. The current travels through a 12 ohm resistor.
  - Calculate the peak current.
  - What is the power dissipated in the resistor?
  - Find the peak voltage drop across the resistor.
- In a circuit whose total resistance is 8.54  $\Omega$ . Find the r.m.s value of the current if the rms voltage of the source is 110 V.

**7.8 Other applications of electromagnetic induction****Activity 7.10**

To establish the application of electromagnetic induction

**Materials**

- Small external speakers
- Two stereo cables
- Two stereo cables cut half with coils of magnet wire on each end
- Small radio

**Steps**

- Turn on the radio and connect the external speakers using the cables till the sound is heard.
- Cut off the cable and replace each end with the modified cable (coils of magnetic wire on each end).



3. Slowly bring the coil close together. What do you hear? Explain
4. In your daily life, you have come across a microphone. Explain how it works.
5. Discuss how the idea of electromagnetic induction is used in transformers.
6. Conduct a research from the internet and reference books on the applications of electromagnetic induction and report to the whole class.
7. With the help of your teacher make short notes from your research and discussion

### 1. Induction coil

An induction coil consists of two coils (secondary and primary coils) with one wound over the other around a soft iron core. The secondary coil has a greater number of turns (Fig. 7.32).

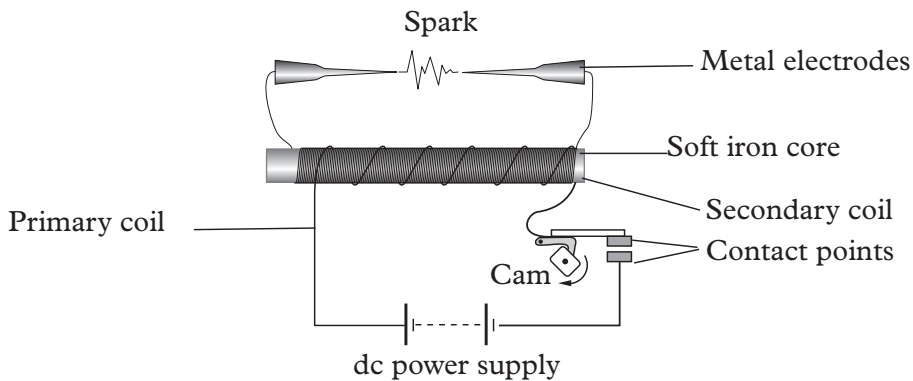


Fig. 7.32: Induction coil

An induction coil works like a step-up transformer but with a d.c power supply. The direct current in the primary coil is switched on and off by a rotating cam. The current in the primary coil produces a changing magnetic field which in turn induces an electromotive force in the secondary coil.

Due to the large number of turns in the secondary coil and the rapid change of current in the primary coil, a large potential difference is induced between the metal electrodes. This large potential difference causes a spark between the metal electrodes. This spark may be used in many ways. For example, the spark produced is used in igniting the petrol-air mixture inside a car's engine.

### 2. Moving coil microphone

A moving coil microphone is a device for changing sound energy into electrical energy. It consists of a diaphragm with a light coil connected to it. This coil is placed in between two poles of a strong cylindrical pot magnet as shown on Fig. 7.33.

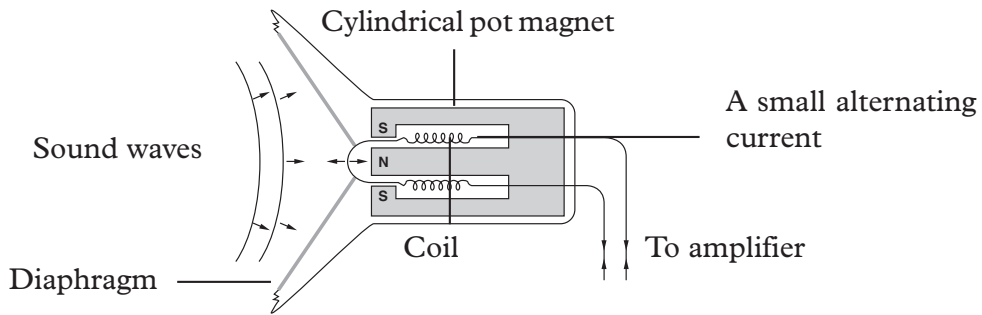


Fig. 7.33: A moving coil microphone

When a person speaks in front of a microphone, the sound energy set the diaphragm into vibration. This moves the coil back and forth between the poles of the magnet. A small alternating current is induced in the coil. When this alternating current is made larger (amplified), it operates a loudspeaker.

#### Exercise 7.4

1. Explain the working principle of a microphone.
2. Fig. 7.34 shows a conductor-carrying a current between the poles of a magnet.

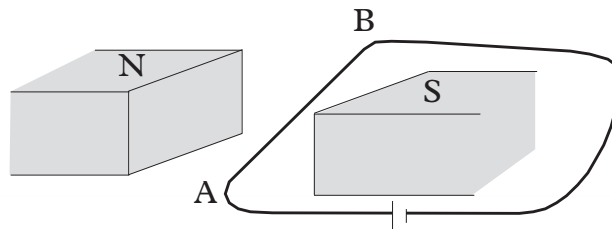


Fig. 7.34: Conductor-carrying current in a magnetic field

- (a) If the wire AB is allowed to move, in which direction will it move?
  - (b) What is the effect of
    - (i) reversing the current?
    - (ii) reversing the magnetic field?
    - (iii) reversing the field and current at the same time?
3. Fig. 7.35 shows a solenoid with a current flowing through it.

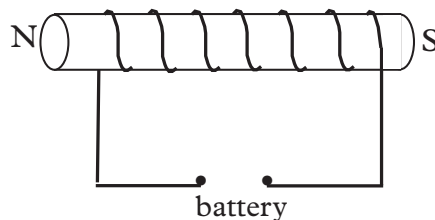
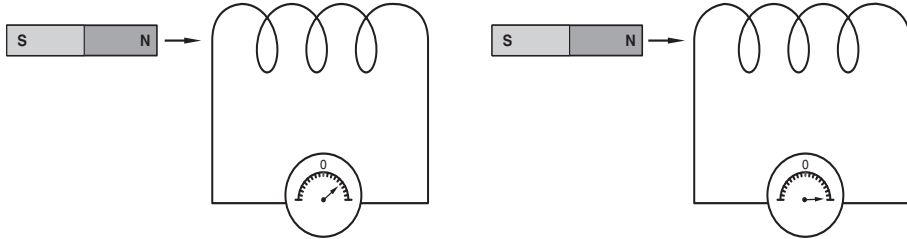


Fig. 7.35: A solenoid

Determine

- (a) The direction flow of the current in the solenoid.
- (b) The polarity of the battery.

4 Look at figure 7.36 illustrating a magnet being moved towards a coil



(a) Magnet moving slowly

(b) Magnet moving fast

Fig. 7.36: Moving a magnet into a coil at different speed

- (a) As the current is induced in the coil, what type of pole is formed at the left end of the coil? Give a reason for your answer.
- (b) In which direction does the conventional current flow through the meter?

### Unit summary and new words

- If a conductor cuts magnetic field lines, an electromotive force is induced. This process of producing electricity is called electromagnetic induction.
- The magnitude of the induced electromotive force is given by the Faraday's law of electromagnetic induction.
- The direction of the induced electromotive force is determined by Lenz's law.
- The magnitude of the induced electromotive force is affected by the rate of change of magnetic field, strength of the magnet, the number of turns of the coil and the material used for the core.
- Fleming's right hand rule is used to show the direction of the induced current in a straight conductor cutting the magnetic field.
- A generator converts mechanical energy to electrical energy.
- Slip rings in an a.c generator reverses the direction of the induced current in the external circuit.

- Split rings or commutator help to maintain the flow of the current in one direction in the external circuit of a d.c generator.
- In both the d.c and a.c generators, the induced electromotive force is maximum when the coil is moving in a direction perpendicular to the direction of the field. It is zero when moving parallel to the direction of the field.

## Unit Test 7

- (a) What do you understand by the term electromagnetic induction?

(b) State the applications of electromagnetic induction.
- You have been provided with the following apparatus: a straight conductor, connecting wires, a horse-shoe magnet and a centre-zero-galvanometer. Describe an experiment to illustrate electromagnetic induction.
- The following apparatus may be used to perform an experiment to demonstrate one of the factors that affect the magnitude of the induced electromotive force; two identical coils, rheostat, dry cells, a switch, connecting wires, a centre-zero-galvanometer.
  - Draw the set-up that you need to assemble to perform the experiment.
  - Describe how the experiment is to be carried out.
  - State the expected results.
- Fig. 7.37 shows a trolley carrying a magnet moving at a high speed towards the coil. The trolley enters and passes through the coil.

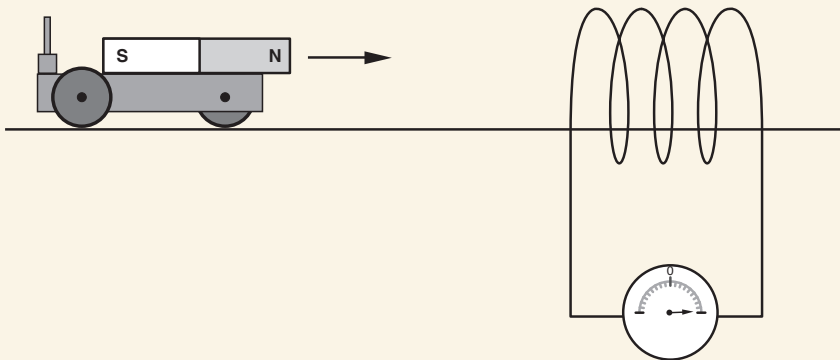


Fig. 7.37: A trolley with a magnetic moving into a coil

- (a) Explain what happens to the needle of the galvanometer when the trolley
- approaches the coil.
  - is moving inside the coil.
  - is moving away from the coil.
  - and the coil are made to move at the same speed in the same direction.

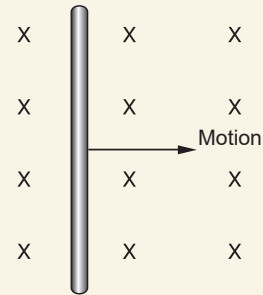


Fig. 7.38: Conductor-carrying current in a magnetic field

- (b) State the energy changes that occur as the trolley enters and leaves the coil.
5. (a) State Fleming's right hand rule.
- (b) Fig. 7.38. shows a conductor moving in a region of a uniform magnetic field.
- State the direction of the magnetic field.
  - What is the direction of the induced current?
  - Give three ways of increasing the magnitude of induced current.
6. (a) Explain the working of a simple a.c generator.
- (b) What changes would you make in the a.c generator in order to produce a larger electromotive force?
7. Fig. 7.39 shows a simple generator.

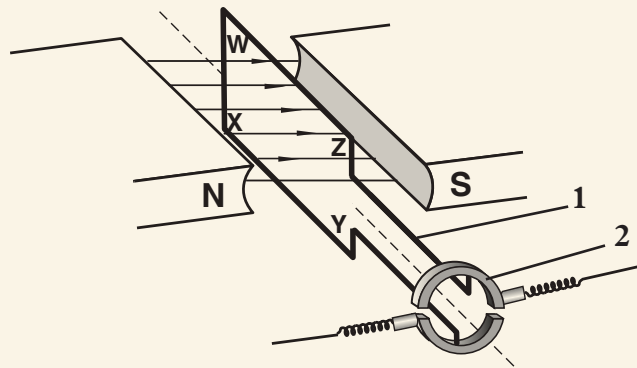


Fig. 7.39: A simple generator

- What is the function of the annular magnets?
- Name the type of the generator.
- What is the function of the parts labelled 1 and 2?
- Explain how the electromotive force is induced in the coil. Sketch the output graph of p.d against time.
- Sketch the variation of the voltage from a.c. generator and use it to define the term peak value and period.

8. Use the words provided below to fill in the blank spaces.

*position, mechanical, dc, current, ac, direction, electrical*

A generator is a device that converts \_\_\_\_\_ energy to \_\_\_\_\_ energy. There are two types of generators commonly the ac and dc generators. A \_\_\_\_\_ generator produces alternating voltage while \_\_\_\_\_ generator produces direct voltage in both types of generators, the direction of the \_\_\_\_\_ induced in the coil depend upon the \_\_\_\_\_ of the coil and the \_\_\_\_\_ in which the coil is moved.

9. Fig 7.40 shows a wire placed in a uniform magnetic field. If the force acting on the wire is into the paper.

- (a) Indicate on the diagram the direction of the current through the wire.  
 (b) Explain what happens when the battery terminals connected to wire AB are reversed.

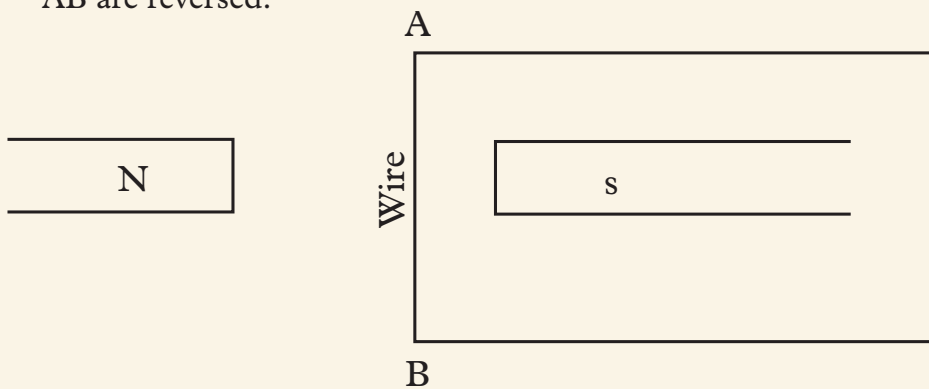


Fig. 7.40

10. (a) What is magnetic flux?

- (b) Fig. 7.41 shows current flowing in a solenoid;

Sketch the magnetic field around the solenoid, clearly indicating the polarities.

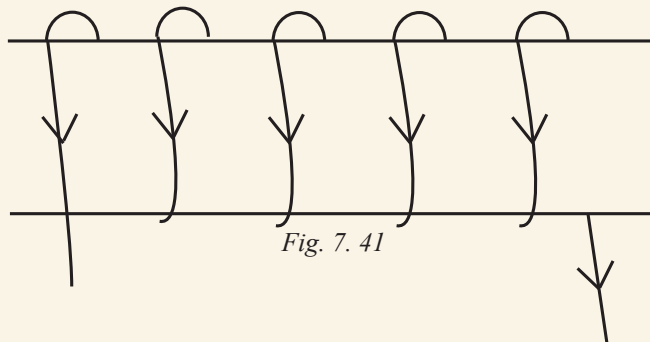


Fig. 7.41

11. The direction of induced current in a conductor moving in a magnetic field can be predicted by applying:

- A** Faraday's law                      **B** Maxwell's screw rule  
**C** Fleming's left hand rule           **D** Fleming's right hand rule

**12. (a)** A cable connected to a centre-zero galvanometer G as shown in Fig. 7.42.

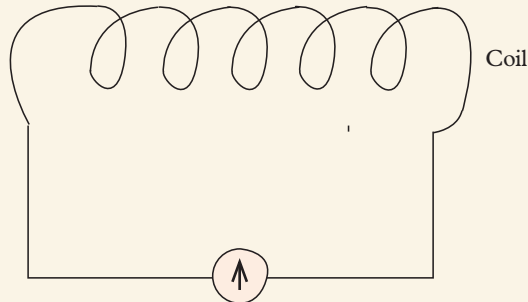


Fig. 7. 42

- (i) State what is observed when the N-pole of a bar magnet is moved towards the coil.
- (ii) State two ways in which the effect observation (a) (i) can be increased.
- (b)** With aid of a labelled diagram describe how a simple a.c generator works.
- 13.** An AC circuit carries an rms current of 5.6 Amps. The current travels through a 90 Ohm resistor.
- (a) What is the peak current?
- (b) What is the power dissipated in the resistor?
- (c) What is the peak voltage drop across the resistor?

**Key Unit Competence**

By the end of the unit the learner should be able to analyse the transmission of electrical power.

**Learning objectives****Knowledge and understanding**

- Explain the use of high-voltage step-up and down transformers and power transmission.
- Describe the transmission of electrical power.
- Outline the reasons for power losses in transmission lines and real transformers.
- Explain the step-up and down transformers and power transmission.
- State dangers of staying near high- voltage power lines.

**Skills**

- Analyse the operation of an ideal transformer.
- Describe a transformer.
- Explain the operation of an ideal transformer.
- Analyse the transmission of electrical power.
- Discover reasons for power losses in transmission lines and real transformers.
- Show possible risks involved in living and working near high- voltage power lines.

**Attitude and value**

- Appreciate the applications of electromagnetic induction.
- Acquire scientific techniques, reasoning and attitudes in analysing theories and expressions.
- Realize reasons for power losses in transmission lines and transformers.
- Develop scientific skills for analysing functioning of ideal transformers.
- Discover other reasons for power losses in transmission lines and real transformers.
- Show the concern of high-voltage step-up and down transformers and power transmission.
- Realise dangers associate with living and working near high - voltage power lines.





## Introduction

### Unit Focus Activity

#### Materials

- Electricity transmission lines in or near your school
- A transformer

#### Steps

1. In unit 7, we learnt about the generation of electricity. How is it transmitted for use?
2. Study the pictures in Fig. 8.1 (a) and (b).

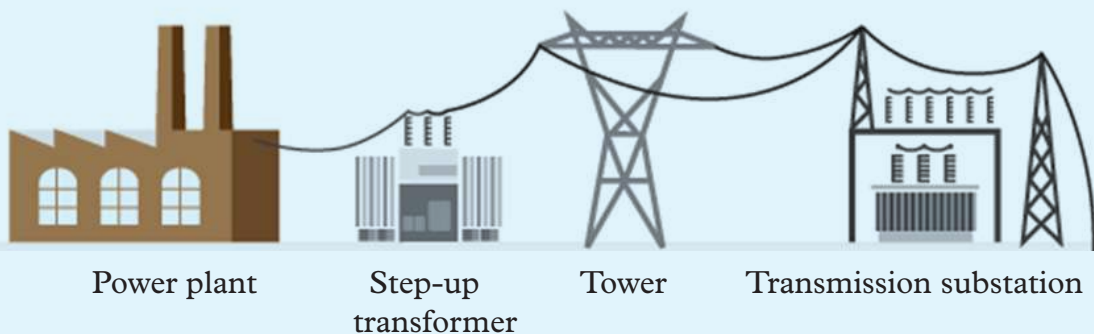


Fig. 8.1(a): Electrical power transmission to an industry.

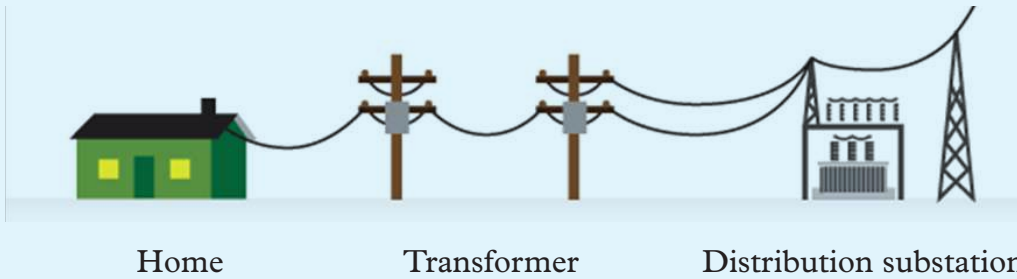


Fig. 8.1(b): Electrical power transmission

3. Describe how electricity is transmitted from a power plant to your home.
4. Rusumo power station produces 80 MW. The power received at a sub-station was 79.9 MW. Explain the loss of 0.1 MW. If you were an electrical engineer at the plant, what could you advise to be done to minimise power loss during transmission.
5. Discuss the dangers associated with the transmission of electric power at high voltage.

After electricity is produced at power plants, it has to get to the customers that use it. Our cities, towns and entire country are crisscrossed by power lines that transmit the electricity. In this unit, we will analyse in details how electrical power is transmitted.

## 8.1 Structure and working of a transformer

### 8.1.1 Structure of a transformer

#### Activity 8.1

To describe the structure and working of a transformers

#### Materials

- Internet
- Reference books
- Transformer in the school or near your school

#### Steps

1. Using a simple drawing, discuss how transformers are made and their functions.
2. Conduct a research from Internet or reference books on transformers. In your research, find out the different types, structure and operations
3. Write a short report on your findings.
4. Present your report to the whole class through your secretary.

As we learnt earlier, a simple transformer consists of two coils insulated from each other and wound on the same soft-iron core. One coil contains a few turns of thick wire and the other coil contains many turns of thin wire. The coil that is connected to *a.c* mains is called the *primary coil (p)* while the one through which the stepped up or stepped down electrical current output is delivered to the outer circuit is called the *secondary coil (s)*.

Fig 8.2 shows the structure of a transformer in which *P* is the primary coil and *S* is the secondary coil.

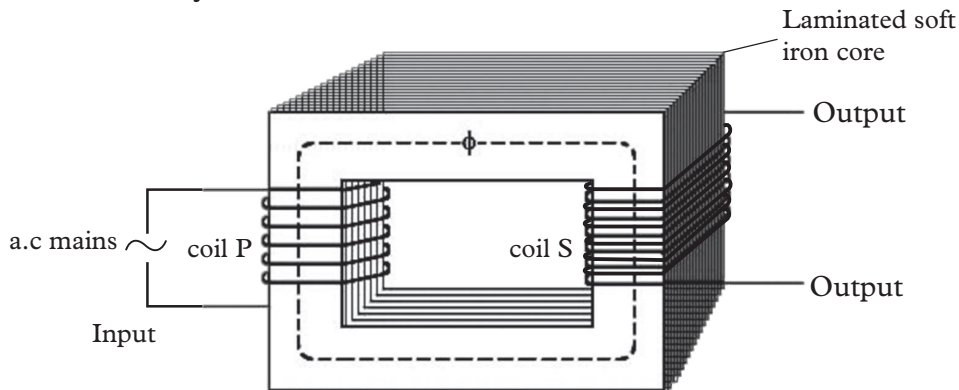


Fig. 8.2: The working of a transformer (mutual induction)

### 8.1.2 The working of a transformer

#### Activity 8.2

To describe the working of transformers

#### Materials

- Insulated copper wires
- Galvanometer
- Switch
- Connecting wires

#### Steps

1. Make two coils using the insulated copper wire. Connect the coils in circuits as shown in Fig. 8.3 (a) and (b).

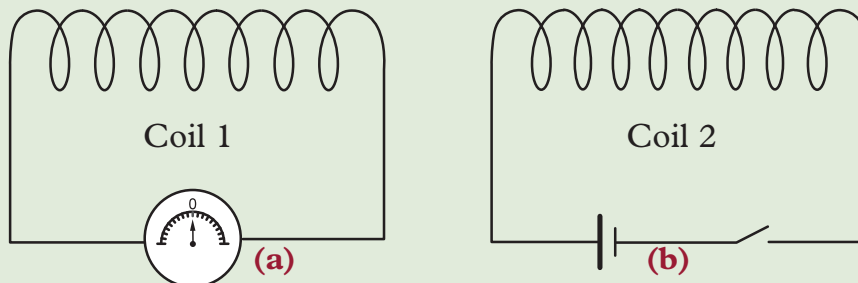


Fig. 8.3: Electromagnetic induction using two coils

2. Close the switch in coil 2. What happens to the pointer of the galvanometer? Explain.
3. Quickly open and close the switch severally. Observe what happens to the galvanometer? Explain your observations.

A transformer is an electric device that transfers electrical energy from one circuit to another by electromagnetic induction. In transferring this energy, a transformer steps up or steps down the voltage or electromotive force from the source.

In Activity 8.2, you must have observed that by switching the current on and off in one coil, an electromotive force is induced in another coil. The circuit that induces the electromotive force is called the *primary circuit*, while the circuit where the electromotive force is induced is called the *secondary circuit*. Although the two coils are not connected, changes in current in the primary circuit induces an electromotive force in the secondary circuit.

This effect is called **mutual induction**. Mutual induction occurs on switching the current on and off in the primary circuit. The switching on and off of the current can also be achieved by replacing the battery and the switch with an a.c power supply as shown in Fig. 8.4 (a). Fig. 8.4 (b) shows how the induced current varies with time.

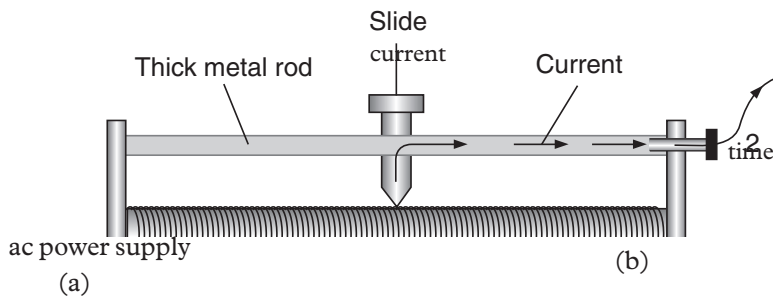


Fig. 8.4: Inducing a current by mutual induction

The mutual induction is more pronounced when the two coils are wound round a **soft iron core**. This was shown by Michael Faraday who used a soft iron ring as shown in Fig. 8.5.

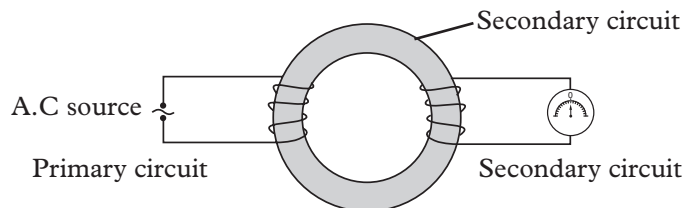


Fig. 8.5: Faraday's ring

The magnitude of e.m.f induced in the secondary coils also depends on the ratio of the number of turns of secondary to primary coils.

### Explaining mutual induction

An electric current creates a magnetic field around the conductor through which it flows. When the current is switched on and off in the primary coil, the strength of the field (magnetic flux) keeps changing from zero to maximum and back to zero (alternating current does this automatically without being switched on and off as it fluctuates from zero to maximum). The change in magnetic flux induces a current in the secondary coil in a way that this current tends to oppose the current in the primary coil, and also fluctuates from zero to maximum. Thus, an a.c input in the primary coil induces an a.c output in the secondary coil (Fig. 8.6 (a)). Thus, the change in the number of magnetic field lines threading the primary coil induces an electromotive force in the secondary coil in an opposite direction in accordance with Lenz's law as shown on Fig. 8.6 (a)).

Soft iron core increases the induced e.m.f because it can easily be magnetised and easily be demagnetised. Soft iron also helps to concentrate the magnetic field lines in the secondary coil (Fig. 8.6 (b)). The induced electromotive force in the secondary circuit has the same frequency as the electromotive force in the primary circuit.

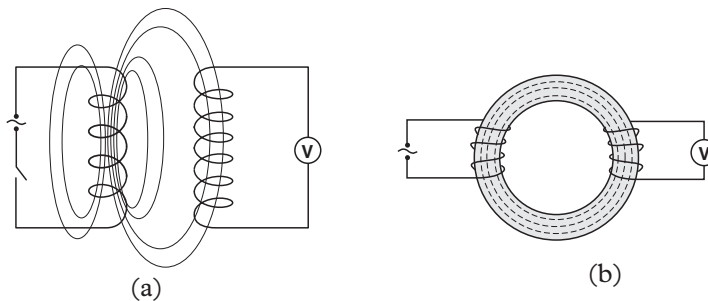


Fig. 8.6: Effects of soft iron core on the number of field lines threading the secondary coil

## 8.2 Types of transformers

### Activity 8.3

To describe types of transformer and their uses

#### Materials

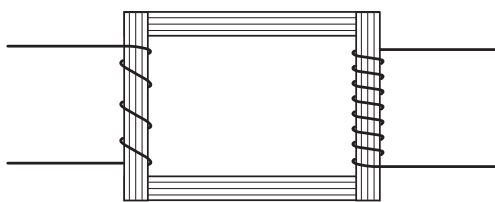
- A transformer within or near the school compound
- Internet
- Reference books

#### Steps

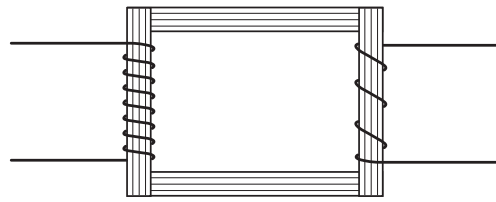
1. Identify a transformer in or near your school. Move close to it. What type of transformer it is? How many types do you know? Name them.

2. Describe some causes of transformer failures..
3. Now do a research on types and uses of transformers.
4. Discuss your findings with other members.

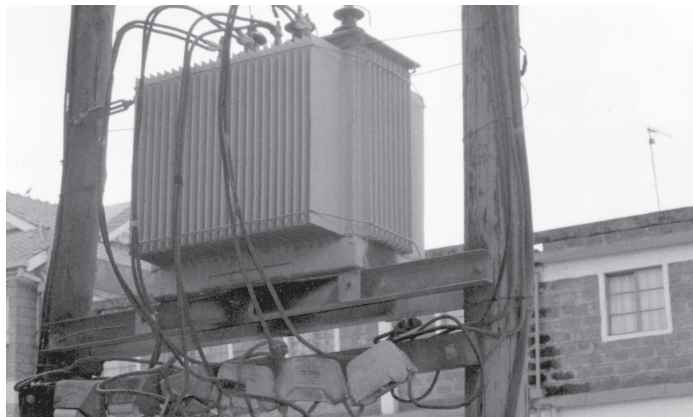
There are two types of transformers, namely, the *step-up* and the *step-down transformers*. In a step-up transformer, the number of turns in the secondary coil  $N_s$  is more than the number of turns in the primary coil  $N_p$  (Fig. 8.7 (a)), while in a step-down transformer, the number of turns in the secondary coil is less than the number of turns in the primary coil (Fig. 8.7 (b)). Fig. 8.7 (c) shows a commercial step-down transformer.



(a) Step-up transformer



(b) Step-down transformer



(c) A commercial step-down transformer

Fig. 8.7: Types of transformers

The terms, step-up and step-down, apply to output voltages of the transformer. When an alternating electromotive force is applied to the primary coil, a changing magnetic field is produced. The soft iron core links this field to the secondary coil. This alternating field produces an alternating electromotive force in the secondary coil through mutual induction.

Fig. 8.8 shows the circuit symbols for the step-down and step-up of transformers.

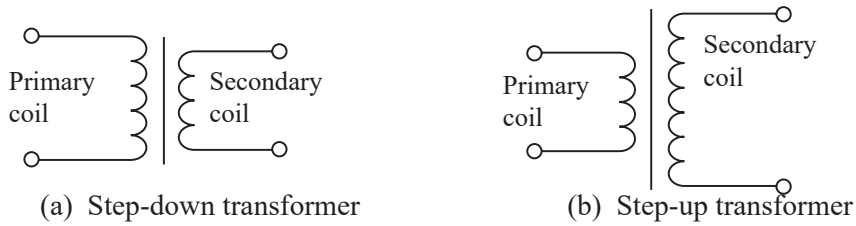


Fig. 8.8: Circuit symbols for transformers

A transformer may have more than one secondary coil. Fig. 8.9 shows a transformer with two coils in the secondary circuit. Such transformers can step-up and step-down voltages simultaneously.

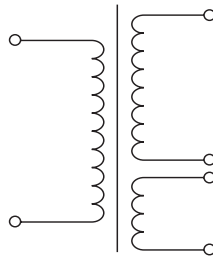


Fig. 8.9: A transformer with two coils in the secondary circuit

### 8.3 Transformer equations

#### Activity 8.4

To investigate the relationship between number of coils and the induced e.m.f

#### Materials

- Connecting wires
- Galvanometer
- Switch
- Insulated copper wire
- Source of current

#### Steps

1. Make two coils (one with more turns than the other) using the insulated copper wire.
2. Connect one coil to the galvanometer and the other coil to the source of current and the switch as shown in Fig. 8.10.

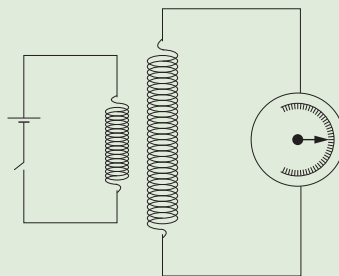


Fig. 8.10: Transformer connected to a galvanometer



3. Bring the two coils close to each other.
4. Close the switch. What do you notice on the pointer of the galvanometer? Record down the reading.
5. Repeat steps 1 to 4 with the galvanometer on the coil with lesser turns.
6. Compare the reading obtained in steps 4 and 5. Which one is larger? Explain.
7. Now discuss in your groups the relationship between the number of turns of the coil and the magnitude of the emf produced.

Table 8.1 shows the results obtained in a similar activity.

Table 8.1

Primary e.m.f ( $\epsilon_p$ ) (V)	Turns in the primary coil $N_p$	Turns in the Secondary coil $N_s$	$\frac{N_s}{N_p}$	Deflection of the galvanometer
1.5	10	5	0.5	Small
1.5	20	5	0.25	Smaller
1.5	30	5	0.17	Smaller
1.5	10	10	1	High
1.5	10	20	2.0	Higher
1.5	10	30	3.0	Higher

From the activity, we can conclude that the magnitude of the induced electromotive force in the secondary circuit is directly proportional to the ratio of the number of turns of coils used.

Let  $V_p$  and  $V_s$  represent the voltage in the primary coil and secondary coils respectively.

$N_p$  and  $N_s$  represent the number of coils in the primary and secondary coils respectively.

Electromotive force induced in the secondary circuit ( $\epsilon_s$ )  $\propto$   $\frac{\text{Number of turns in secondary coil, } N_s}{\text{Number of turns in primary coil, } N_p}$

$$\text{i.e. } \epsilon_s \propto \frac{N_s}{N_p}$$

When the experiment is done using an a.c power supply, it can be shown that

$$\frac{\text{Secondary e.m.f, } V_s}{\text{Primary e.m.f, } V_p} = \frac{\text{Number of turns in secondary coil, } N_s}{\text{Number of turns in primary coil, } N_p}$$

$$\frac{V_s}{V_p} = \frac{N_s}{N_p} \dots\dots\dots (1)$$

In an ideal case (no power loss), the electric power ( $P = VI$ ) in the primary coil is equal to that in the secondary. Thus, when the voltage is stepped up, the current is stepped down and vice versa.



Hence in such a case,

$$\frac{I_s}{I_p} = \frac{N_p}{N_s}$$

Noted that, the e.m.f induced in the secondary coil is maximum when the two coils are close together and when wound on a soft iron core.

When the emf in the transformer is maximized, it is transmitted to different places through cables. Among the many risks involves when transmitting high voltage include electric shock incase the poles collapse and fire outbreak on structures and vegetation.

### 8.3.1 Efficiency of a transformer

As mentioned earlier, a transformer transfers electrical energy from one circuit to the other. The energy per second, supplied to the primary coil is called the power input, while the energy obtained per second from the secondary coil is the power output. In an ideal transformer, the power output is equal to power input. The term efficiency is used to indicate how effective a transformer is in transferring the input energy to output energy.

The efficiency of a transformer is the ratio of the power output to power input expressed as a percentage.

$$\text{Efficiency} = \frac{\text{power output}}{\text{power input}} \times 100\%$$

The term *efficiency* is used to indicate how effective a transformer is in transferring the input energy to output energy.

Well designed practical transformers often have efficiency as high as 98%.

For an **ideal transformer** power output = power input (**efficiency 100%**)

$$\text{Efficiency} = \frac{\text{power output}}{\text{power input}} \times 100\% = 100\%$$

$$\text{power input} = V_p I_p; \quad \text{power output} = V_s I_s$$

$$V_p I_p = V_s I_s;$$

$$\therefore \frac{V_s}{V_p} = \frac{I_p}{I_s} \dots\dots\dots (2)$$

Where  $I_p$  and  $I_s$  are the current in primary coil and in secondary coil respectively. Hence from the equation (1) & (2) we obtain:

$$\frac{V_s}{V_p} = \frac{I_p}{I_s} = \frac{N_s}{N_p}$$

And  $N_p I_p = N_s I_s$  ..... (3)

Equations 2 and 3 can be used to calculate the current in transformers coils.

**Be Safe!**

Note that a transformer can be disastrous if tampered with. It can cause death, fire on premises and surrounding vegetables.  
Do not tamper with a transformer in your places.

**Example 8.1**

An alternating electromotive force of 240 V is applied to a step-up transformer having 200 turns on its primary coil and 4 000 turns on its secondary coil. The secondary current is 0.2 A. Calculate the

- (a) (i) Secondary electromotive force.      (ii) Primary current.
- (iii) Power input.                              (iv) Efficiency.
- (b) Comment on the answer to (iv).

**Solution**

(a) (i)  $\frac{V_s}{V_p} = \frac{N_s}{N_p}$

$$V_s = \frac{V_p \times N_s}{N_p}$$

$$= \frac{240 \times 4\,000}{200}$$

$$= 4\,800 \text{ V}$$

(ii)  $\frac{I_s}{I_p} = \frac{N_p}{N_s}$

$$I_p = \frac{N_s \times I_s}{N_p}$$

$$= \frac{4\,000 \times 0.2}{200}$$

$$= 4.0 \text{ A}$$

(iii) Power input =  $I_p \times V_p$

$$= 4 \times 240$$

$$= 960 \text{ W}$$

(iv) efficiency =  $\frac{\text{Power output}}{\text{Power input}} \times 100\%$

$$= \frac{I_s \times V_s}{960} \times 100\%$$

$$= \frac{0.2 \times 4800}{960} \times 100\%$$

$$= 100\%$$

(b) Since the efficiency of this transformer is 100%, then it is an ideal transformer.

**Example 8.2**

A step-down transformer is connected to a 240 V alternating current power supply. The primary coil has 1000 turns. How many turns should the secondary coil have so as to operate a 12 V alternating current toy car?

**Solution**

$$\frac{V_s}{V_p} = \frac{N_s}{N_p} \Leftrightarrow \frac{12}{240} = \frac{N_s}{1000} \Rightarrow N_s = 50 \text{ turns}$$

**Example 8.3**

A transformer has an input coil of 60 turns. When this coil connected to a 240 V source, the output voltage is found to be 4 800 V. The output power is 3 600 W.

- (a) Calculate the number of turns in the output coil.  
 (b) If the efficiency of the transformer is 80%, calculate the  
 (i) output current  
 (ii) input current.

**Solution**

- (a)  $N_p = 60$ ;  $V_p = 240 \text{ V}$ ;  $V_s = 4800 \text{ V}$ ;  $N_s = ?$

$$\begin{aligned} \frac{V_s}{V_p} = \frac{N_s}{N_p} &\Rightarrow \frac{4800}{240} = \frac{N_s}{60} \quad N_s = \frac{4800 \times 60}{240} \\ &= 1200 \text{ turns} \end{aligned}$$

- (b) (i)  $P_o = V_s I_s$

$$\begin{aligned} 3600 = 4800 I_s &\Rightarrow I_s = \frac{3600}{4800} \\ &= 0.75 \text{ A} \end{aligned}$$

- (ii) Efficiency (E) =  $\frac{P_i}{P_o} \times 100\% = \frac{V_s I_s}{V_p I_p} \times 100\%$

$$\begin{aligned} 80 &= \frac{4800 \times 0.75}{240 \times I_p} \times 100\% \\ &= \frac{360000}{240 I_p} \times 100\% \end{aligned}$$

$$I_p = \frac{360000}{240 \times 80} = 18.75 \text{ A}$$

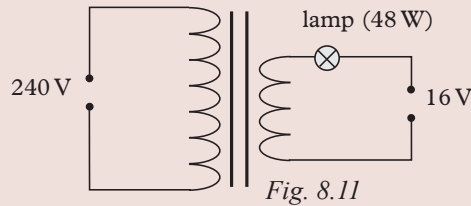
**Example 8.4**

An ideal transformer is used to operate a 16 V, 48 W lamp from a 240 V mains supply. Its primary coil has 450 turns.

- Draw a well labelled sketch of the transformer.
- How many turns does the transformer have in its secondary coil?
- What is the current flowing in the mains?

**Solution**

(a)



(b)  $N_p = 450$ ;  $V_p = 240$  V;  $V_s = 16$  V;  $N_s = ?$

$$\frac{V_s}{V_p} = \frac{N_s}{N_p} \Rightarrow \frac{16}{240} = \frac{N_s}{450}$$

$$N_s = \frac{450 \times 16}{240}$$

$$= 30 \text{ turns}$$

(c) The current flowing in the mains is given by.

$$I_s = \frac{P}{V} = \frac{48 \text{ W}}{16 \text{ V}} = 3 \text{ A}$$

$$\text{For an ideal transformer, } \frac{N_s}{N_p} = \frac{I_p}{I_s} \Rightarrow \frac{30}{240} = \frac{I_p}{I_s}$$

$$\text{Hence } I_p = \frac{30 \times 3 \text{ A}}{240} = 0.375 \text{ A}$$

**8.4 Power losses in a real transformer****Activity 8.5**

To find out the factors that contribute to power losses in a transformer

**Materials**

- Internet
- Reference books

**Steps**

- In groups, suggest and explain some of the factors that contribute to power loss in a transformer.

2. Now conduct a research from the internet and reference books on factors that contribute to the loss of power in a transformer. Compare them with the ones you suggested in step 1. How right were you?
3. In your research, also find out the application of transformers.
4. Give a presentation on your finding to the whole class through your group secretary.

The energy supplied in the primary circuit of a transformer is lost in a number of ways. The following factors contribute to the overall power loss and therefore affects the efficiency of a real transformer.

### 1. Resistance of the coils

As the current flows in the coils, the wires heat up and energy is lost in form of heat.

$$\text{Energy lost} = I^2 \times R \times t$$

This method of losing energy is called *joule-heating*.

To *minimise energy loss* in this way, *thick copper wires of low resistance are used* where large currents are to be carried.

### 2. Eddy currents

When the magnetic field changes, small amount of current called *eddy currents*, are induced in the core of the transformer. This heats up the core and *energy is lost in form of heat*.

To *minimise this loss of energy*, *the core is laminated and insulated between the laminations*. This reduces the magnitude of the eddy currents.

### 3. Hysteresis losses

The magnetisation and demagnetisation of the core by the alternating magnetic field requires energy. This energy heats up the core and is lost as heat energy. This method of losing energy is called *hysteresis loss*.

To *minimise this loss of energy*, the *core is made of a soft magnetic material that is easy to magnetise* and demagnetise e.g. soft iron.

### 4. Flux or magnetic leakage

Not all the magnetic field lines of force due to the primary coil may link the secondary coil resulting in what is called *flux leakage as shown on Fig. 8.12 (a)*.

To *reduce this loss*, the *core is designed in such a way that almost all the magnetic effect due to the primary coil is transferred to the secondary coil* e.g. using a loop.

(Fig. 8.12 (b)).

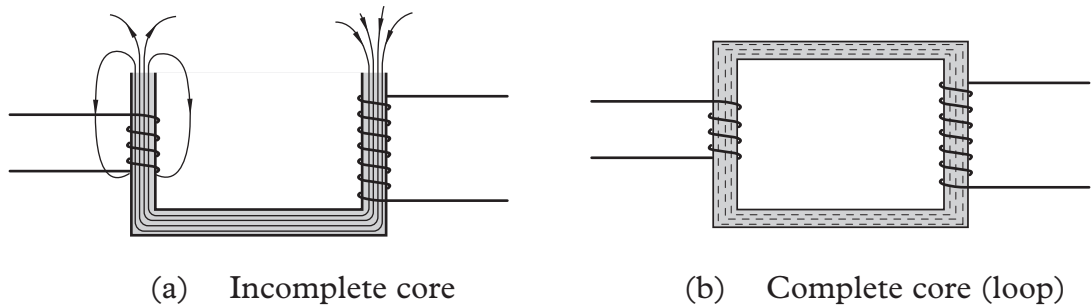


Fig. 8.12: Magnetic or flux leakage

Since it is not possible to completely reduce energy losses in transformers, very large transformers are *oil-cooled* to reduce *overheating otherwise* they will cause fire and thus massive destruction to the surrounding.

## 8.5 Applications of transformers

**1. Transformers are used in the National Grid system to step-up or down voltage and current.**

Electric power is usually transmitted over long distances at very high voltage e.g 11 000 V and at low current to minimize power loss due to internal heating ( $I^2R$ ). Transformers are used to step-up voltage at the power station and step-down e.g 240 V for use in a home.

**2. Transformers are used in electric welding**

Electrical welding machines use electricity at high current to melt metals.

For example, a transformer with 800 turns in the secondary coil and only 5 turns as primary, steps-up current in the ratio of 160:1. In a perfect transformer (step-up), the current is stepped up in the same ratio. A current of 1 A in the primary might give a current of 160 A in the secondary. This large current heats the metal until it melts. The current can be used to weld two metals together.

### Exercise 8.1

1. (a) Name two type of transformers.
- (b) Explain the structure of each type of transformer.
- (c) Describe the working principle of transformers.

2. A student designed a transformer to supply a current of 10A at a potential difference of 60V. If the efficiency of the transformer is 80%, calculate
  - (a) The power supplied to the transformer.
  - (b) The current in the primary coil.
3. Describe the energy changes in a transformer.
4. Give two factors that affect the efficiency of a transformer.
5. Fig. 8.13 shows a transformer with 400 turns in the primary coil and 1000 turns in the secondary coil.

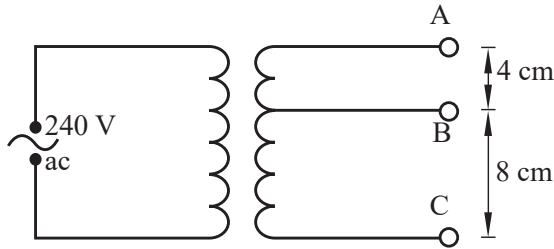


Fig. 8.13

- (a) What type of transformer is it?
  - (b) Find the potential difference across BC.
  - (c) What assumption(s) have you made?
6. A transformer is used to operate a 9 V ac shaving machine (Fig. 8.14).

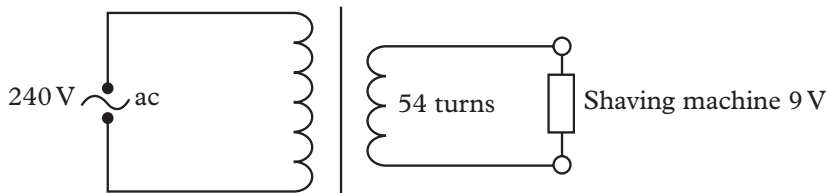


Fig. 8.14

- (a) Explain why the primary coils should be made of thicker wire than that of the secondary coils.
  - (b) How many turns are there in the primary coil?
  - (c) Explain what would happen to the transformer if a 240 V dc power supply is used instead of 240 V mains.
  - (d) What happens to the primary current when the machine is being used?
7. A step-down transformer has a primary coil with 800 turns and secondary coil with 100 turns. The primary coil is connected to 240 V supply.
  - (a) Find the voltage output.
  - (b) If the transformer has a primary current of 0.10 A and of secondary 0.72 A, calculate its efficiency.

## 8.6 Electric power transmission

### 8.6.1 The grid power transmission system

#### Activity 8.6

To describe the transmission of electrical power

#### Materials

- Cables of different thickness made of different metals (e.g copper, aluminium steel etc)
- Reference books
- Internet

#### Steps

1. Identify overhead wires used to transmit electricity near or in your school. Tell your classmates the materials used to make the overhead wires you have identified.
2. Observe the cables provided to you. By giving appropriate reason, identify which one is suitable for the transmission of electricity. Which cable would contribute to loss of more electric energy than the other? Explain.
3. Now, conduct a research from the Internet and reference books on transmission of electrical power. In your research, find out:
  - (a) Ways in which electrical power transmitted is lost during transmission and how to minimise it.
  - (b) How electricity is transmitted and the dangers it exposes to the people in the surrounding.
4. Share your report on your findings to the whole class.

The electrical energy generated at a power station is delivered to consumers through cables. It is distributed to consumers all over the country through the *National Grid System* which consists of a network of transmission cables carried over through structures called *pylons*.

Fig. 8.15 shows pylons and cables carrying electricity from a generating station to the consumers.





Fig. 8.15: Pylons and electricity transmission cables

Electrical power is generated at a relatively high current (e.g at 100 A and 25 kV), its voltage is immediately stepped up using a *step-up transformer* at the generating station, automatically stepping down its current for transmission through the grid (e.g. at 6.25 A and 400 kV). On reaching the consumer, the voltage is stepped down to a low value e.g. 240 V for use in a home by a *step-down transformer* placed near the home.

Fig. 8.16 shows a section of a typical National Grid System from the power generating station to the factories, towns and villages.

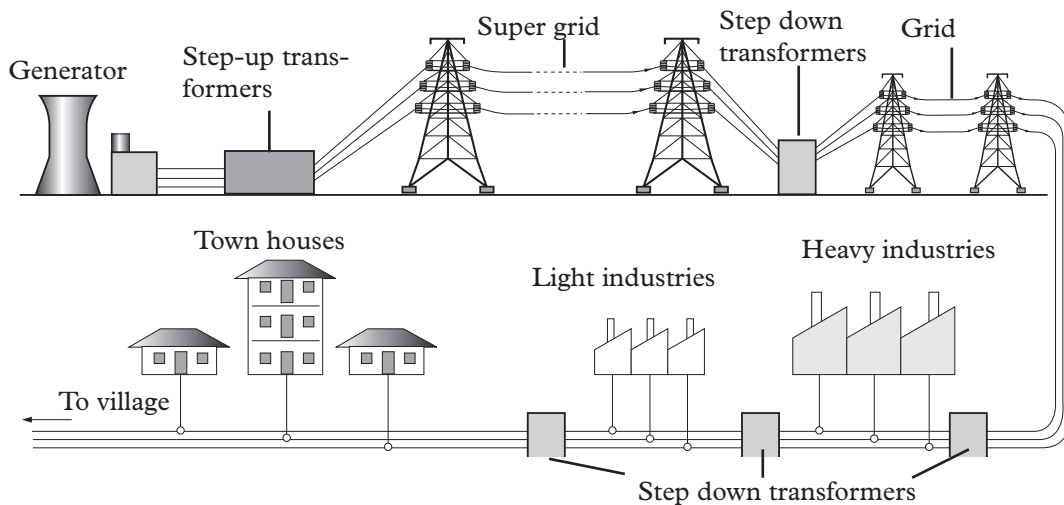


Fig. 8.16: The National Grid System

### 8.6.2 Power loss in transmission cables

Due to *electrical resistance* ( $R$ ) of the transmitting cables, some electric power (Given by  $P = I^2R$ ) is *lost in form heat* in the transmission cables.

*Remember*, the electrical resistance of a wire (conductor) is directly proportional to its length and inversely proportional to its cross-sectional area ( $A$ ), that is;

$$(R = \rho \frac{L}{A}).$$

This means that a long thin wire has high electrical resistance than a short thick wire. As such, a very high quantity of electric power would be lost if electric power is transmitted at high current and through thin wires in the National Grid.

To reduce power loss in transmission cables,

1. Very thick transmission wires are used.
2. The transmission wires are made of metals like copper that are very good conductors of electricity hence have very low electrical resistance.
3. Electric current is transmitted at very high voltage and very low current.

### 8.6.3 Advantages of a.c over d.c. power transmission

1. An a.c. voltage can be easily and cheaply stepped up or down from one voltage value to another by a transformer while d.c power cannot.
2. An a.c. voltage can be transmitted over long distances at high voltage and low current with minimum power loss, while d.c. cannot be transmitted over a long distance even at high voltage and low current because a lot of electrical power will be wasted as internal energy warms the transmission cable.

### 8.6.4 Dangers of high voltage transmission

#### Activity 8.7

#### To find out the danger of high voltage transmission

##### Materials

- Internet
- Reference books

##### Steps

1. Suggest some of the dangers of high voltage transmissions.
2. Conduct a research from the internet or reference books on the dangers associated with high voltages power transmission.
3. In your research, find out the diseases likely to be caused in one living near high voltage power lines.
4. Give summarized report on your finding through your group secretary.

Due to the high voltages in the transmission cables, a strong electric field is setup between the cables and the earth. Air, an insulator under normal conditions, may start to conduct electricity especially on rainy days. People or animals in the vicinity may get electrocuted. To minimise this danger, transmission cables carrying high voltages are supported high above the ground by *pylons*. When the cables enter towns and cities, they are buried underground.

**Caution**

Avoid touching loosely hanging electric cables. You will be electrocuted.

**8.6.5 Danger of living and working near high voltage power lines**

Living near high-voltage power lines and towers expose one to the electrical and magnetic radiation produced by these high-voltage wires. Long-term exposure is likely to cause several health problems.

Some of these include:

**1. Risk of electric shock**

There is high risk of electric shock involved when transmitting high-voltage power. For example, if the pole collapses or cables hang too low, they can give electric shock to human beings and animals when they come into contact. This may result in death.

**2. Risk of fire**

When the high-voltage cables fall on structures and vegetation they cause fire. This can lead to massive destruction of property and plants.

**3. Childhood leukemia**

A research conducted in 1979 indicates that children living near high voltage power lines and towers are at high risks of suffering from leukemia than their counterparts who live far away. However, no evidence has been provided to establish a direct connection between childhood leukemia and electromagnetic fields produced by high-voltage power lines.

**4. Cancer**

Long exposure to electromagnetic field radiation from high-voltage power lines and towers, may result in incidences of cancer. Research has indicated that people who live within a 50 m radius of power lines had 99% chances of developing cancer as compared to those who are 500 m away.

**5. Depression**

A research conducted on the psychological effect of living close to high-voltage power lines shows exposure to extremely low frequency electromagnetic fields might contribute to the number of depression-related suicides in people living close to high-voltage power sources.

In addition, many researchers have discovered a link between people living near high-voltage power lines and a number of health concerns, including brain cancer, miscarriage, breast cancer, birth defects, fatigue, hormonal imbalance, decreased libido, sleeping disorder, heart disease and so on.

## 8.6.6 Environmental impact of power generation and transmission

### Activity 8.8

To find out the environmental impact of power generation and transmission

#### Materials

- Reference books
- Internet

#### Step

1. Brain storm among yourselves what impacts power generation and transmission has on the environment.
2. Note down your points.
3. Conduct a research from the internet and reference books to verify your suggestions.

Generation and transmission of power have both positive and negative impacts on the environment. Before a power plant is constructed, one has to know the environmental and health consequences of electricity generation and transmission. Electric power is generated through sources like *hydroelectric, nuclear reactions, fossil fuels, solar, geothermal energy and biomass.*

Hydroelectric power is one of the most commonly generated power in the world. This method of power generation is cheaper, has low operating costs, compared to other methods of generating electricity like electricity from fossil fuels or nuclear energy.

Some of the negative impact of hydroelectric power generation and transmission on the environment are:

- Displacement of people living around the place where a dam has to be constructed.
- Releasing carbon dioxide during construction and flooding of the reservoir.
- Disrupting the aquatic ecosystems and animal life.
- Can be catastrophic if the dam wall collapses e.g can cause flooding.
- The dam becomes a breeding site of mosquitoes which carry and transmit malaria.

Environmental impact from the generation and transmission of power from other sources include:

- Pollution from fossil fuels.
- Dangers of exposure to radioactive materials from nuclear generation.

**Caution**

Malaria is a killer disease. It can be prevented by keeping mosquitoes away i.e sleeping under a mosquito net.

While planning to build a dam, for hydroelectric power, one has to make sure that there are minimal negative effects in the environment.

**Think about this!**

How electricity produced through nuclear reaction and fossils fuel impact the environment.

**Exercise 8.2**

1. (a) Briefly explain how electricity transmitted from Mukungwa power station to your school.  
(b) Discuss the risk involved in the high-voltage transmission.
2. The resistances of a length of power transmitting cables is  $10\ \Omega$  and is used to transmit 11 kV at a current of 1A.If this voltage is stepped-up to 16 kV by a transformer, determine the power loss.
3. A generator produces 660 kW at a voltage of 10 kV.The voltage is stepped up to 132 kV and the power transmitted through cables of resistance  $200\ \Omega$  to a step-down transformer in a sub-station. Assuming that both transformers are 100% efficient:
  - (a) Calculate the
    - (i) current produced by the generator
    - (ii) current that flows through the transmission cables
    - (iii) voltage drop across the transmission cables
    - (iv) power lost during transmission
    - (v) power that reaches the sub-station
  - (b) Repeat (a)(i) to (v), but this time the 10 kV is stepped up only 20 kV instead of 132 kV for transmission.
  - (c) Briefly explain three factors that contributes to power loses in a transformer.
4. State the ways through which power loss in transmission cables is minimised..

## Project work 8.1:

### Construction of a simple transformer

#### Materials needed

- Dry cells
- Bulb
- Insulated copper wires
- Masking tape or a cloth tape
- Soft iron sheets or blades,
- Connecting wires
- Sheets of paper

#### Assembly

- Make a complete soft iron core by packing a number of soft iron blades together. Use sheets of paper to separate the soft iron blades. (Fig. 8.17).

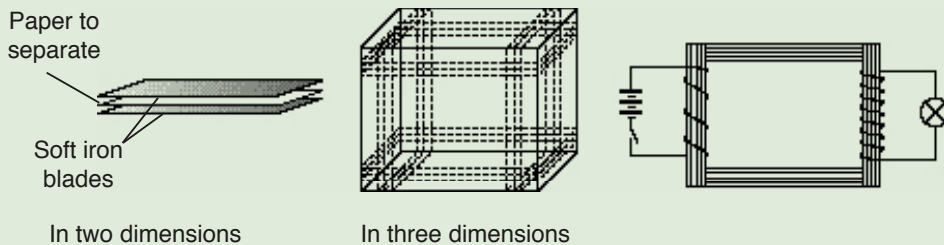


Fig. 8.17: A simple transformer

- Use the masking tape to hold the bundles of soft iron blades together. Make 20 turns of the primary coil and 40 turns of the secondary coil. Connect the ends of the primary coil to three dry cells in series with a switch. To the ends of the secondary coil, connect a small bulb.
- Switch the circuits on and off the circuit rapidly and note what happens to the bulb.

#### Unit summary and new words

- A transformer is an electrical device that transfers electrical energy between two or more circuits through electromagnetic induction.
- There are two types of transformers; step down and step up.
- In a step down transformer, primary turns are many than secondary turns.
- In a step up transformer, secondary turns are main than primary turns.
- Power loses in transformers occurs through
  - (i) Resistance of the coils
  - (ii) Eddy current in transformers

(iii) Hysteresis

(iv) Flux or magnetic leakage

- In transformers;  $\frac{N_s}{N_p} = \frac{V_s}{V_p}$
- For an ideal transformer,  $\frac{I_p}{I_s} = \frac{N_s}{N_p}$
- The efficiency of an ideal transformer may be calculated from:

$$\text{Efficiency} = \frac{\text{Power output}}{\text{Power input}} \times 100\%$$

- Power losses in a transformer occur due to resistance in the coils, eddy currents, hysteresis losses and magnetic flux leakage.
- Electricity is transmitted through cables at high voltage and lower current from power stations to the consumers.
- Power loss in transmission cables occurs due to resistance in the wires. It is minimised by using thick wires of good conducting material and transmission at high and low current.
- Dangers associated with power transmission include risk of shock to people living near the lines.

## Unit Test 8

**For questions 1 to 4, choose the most appropriate response from the choices given.**

1. Conductors for high voltage transmission lines are suspended from towers
  - A. to reduce clearance from ground.
  - B. to increase clearance from ground .
  - C. to reduce wind and snow loads.
  - D. to take care of extension in length during summer.
2. The most main disadvantages of using high voltage for transmission is
  - A. The increased cost of insulating the conductors.
  - B. The increased cost of transformers, switch gear and the other terminal apparatus.
  - C. Both (a) and (b)

- D. There is a reduction in the corona loss
3. What is the main reason for using high voltage for the long distance power transmission?
- A To reduction in the transmission losses.
  - B To reduction in the time of transmission.
  - C To increase system reliability.
  - D None of the above.
4. Which of the following statements is true?
- A. at higher voltage, cost of transmission is reduced
  - B. at higher voltage, cost of transmission is increased
  - C. at higher voltage efficiency decreased
  - D. all of the above
5. (a) Explain the term mutual induction.  
(b) Why is a complete core (loop) used in transformers?  
(c) Distinguish between step-up and step-down transformers.  
(d) Explain why a transformer will only work with an alternating voltage.
6. A transformer has 400 turns in the primary winding and 10 turns in the secondary winding. The primary electromotive force is 250 V and the primary current is 2.0 A. Calculate:
- (a) the secondary voltage.
  - (b) the secondary current assuming 100% efficiency.
  - (c) describe two features in a transformer design which help to achieve high efficiency.
7. Explain two environmental impacts of generating and transmission of electric power.
8. The secondary circuit of a transformer is connected to a bulb rated at 12 V, 40 W. The primary circuit has 5000 turns on the primary and the secondary has 250 turns. If the bulb is operating normally, find:
- (a) The input voltage to the transformer.
  - (b) The current flowing through the bulb
  - (c) The power taken from the supply if the efficiency of the transformer is 90%.
9. A power station has an output of 100 kW at a p.d. of 800 V. The voltage is stepped up to 33 kV by transformer  $T_1$  and transmitted along a grid of resistance 0.85 k $\Omega$ . It is then stepped down to a pd. of 500 V by transformer  $T_2$  at the end of the grid for use in a light industry. Given that the efficiency of  $T_1$  is 95% and that of  $T_2$  is equal to 90%, calculate to 2 decimal places the:
- (a) power output of  $T_1$
  - (b) current in the grid
  - (c) power loss in the grid
  - (d) input voltage of  $T_2$
  - (e) maximum power and current available for use in the industry.



## UNIT

## 9

## Electric Field Intensity

## Key Unit Competence

By the end this unit the learner should be able to calculate intensity of electric field due to one or more point charges

## Learning objectives

## Knowledge and understanding

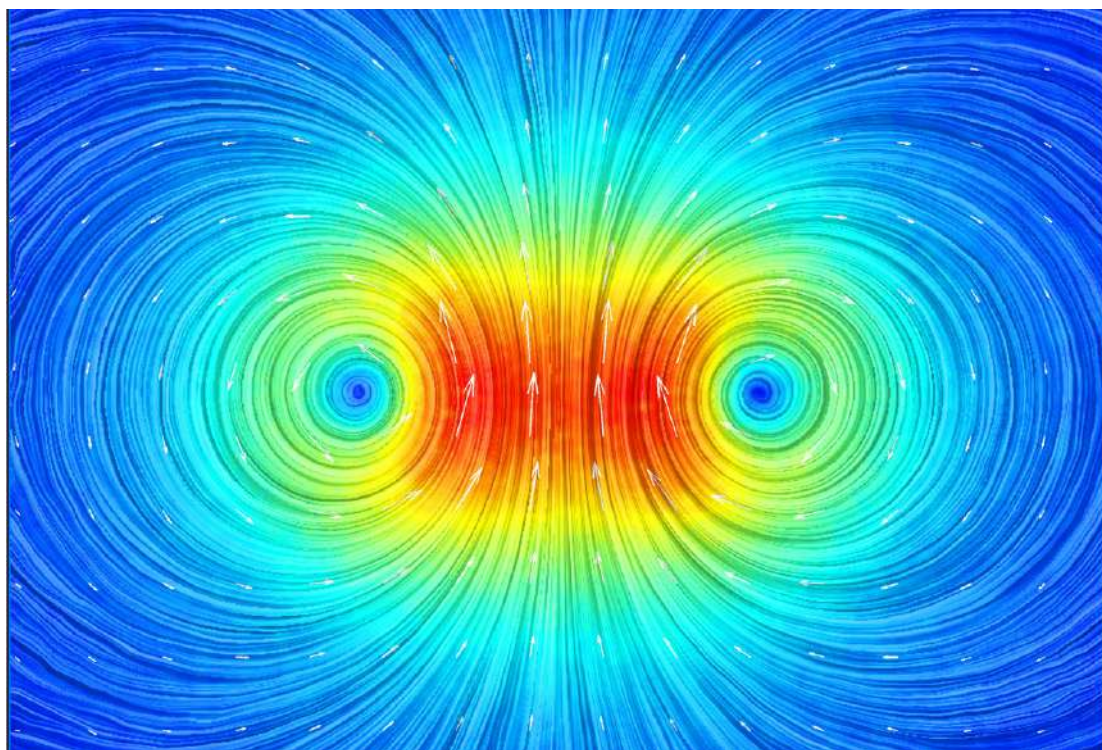
- Illustrate electric field patterns due to two charges.
- State the principle of superposition for point charges in an electric field.
- Describe field patterns for two point charges.
- Explain the intensity of electrical field to the position of charge.
- Explain electric field intensity at different points due to a charge
- Explain superposition of parallel electric fields.

## Skills

- Describe the electric field patterns due to like charges, and unlike charges.
- Relate the intensity of electric field to the position of charge.
- Differentiate electric force and electric field.
- Compare the electric field intensity at different points
- Determine the electric field intensity due to one or more charges.

## Attitude and value

- Appreciate the applications of electrostatic force.
- Show concern about dangers of electric field and how to minimize hazards.
- Acquire ability to think logically and systematically as you pursue a particular line of thought.
- Adapt scientific method of thinking applicable in all areas of life.
- Acquire knowledge for analysing and modelling physical processes.



## Introduction

### Unit Focus Activity

1. Draw the electric field pattern between:
  - (a) a positive and negative point charges,
  - (b) two positive charges.
2. (a) Define the term electric field intensity and state the factors that determine its magnitude.  
(c) Fig. 9.1 shows the electric field around three charges A, B and C. Compare the electric intensity for the three charges.

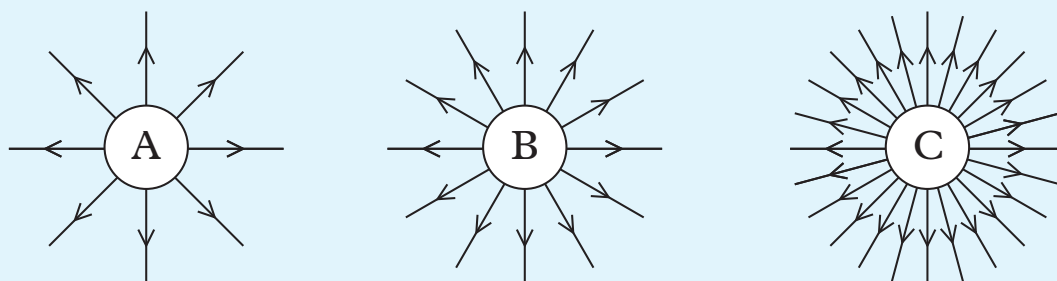


Fig. 9.1: Three electric fields

3. Fig. 9.2 shows a small pith ball of charge  $Q_o = -2 \times 10^{-6}$  C placed between positively charged metal sphere A with charge  $Q_a = 5 \times 10^{-6}$  C and negatively charged metal sphere B of charge  $Q_b = -9 \times 10^{-6}$  C, 25 cm from each charge.

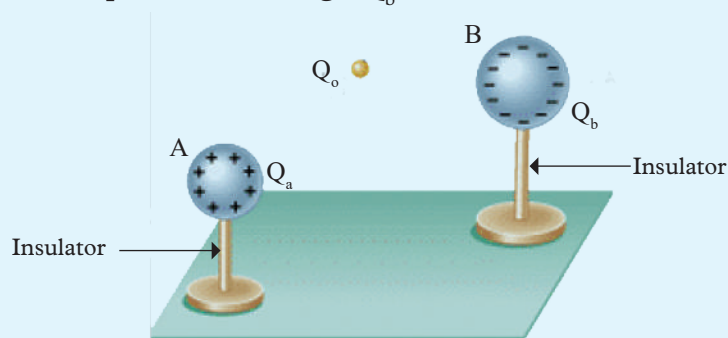


Fig. 9.2: Superposition of electric fields

- Determine the magnitude and direction of the resultant force on the pith ball.
- State the principle you have used to work out part (a)
- Present your findings to the rest of the class in a class discussion.

In lower classes we were introduced to electrostatics. We learnt among other concepts the law of electrostatics and Coulombs law. In this unit, we will further our knowledge by analysing the strengths of electric fields and the interaction of electric fields. This interaction is known as superposition of electric fields.

## 9.1 Electrostatic force and Coulombs law

### Activity 9.1

To demonstrate the electrostatic law between two negatively charged polythene rods

#### Materials:

- Two identical polythene rods A and B
- A silk cloth
- Clamp and a stand
- Thread

#### Steps

- Charge two polythene rods negatively by rubbing them with a silk cloth. Suspend rod A on a stand.
- Bring charged rod B (touching it using a stirrup cloth) near the suspended polythene rod A.
- While varying the distance of the rod A from B, note the magnitude of the force of repulsion. Comment on the relationship between the distance and the force.
- Charge the two rods with the silk cloth more vigorously while maintaining the distances and repeat steps 2 and 3. What do you observe?
- State the effect of the amount of charge on the force of repulsion.
- Discuss the observation made with other members of your group.

In S1, we learnt that objects get charged by induction, friction and by contact methods. Attraction occurs between unlike charges and repulsion occurs between like charges.

In 1784, a French physicist Charles Augustine Coulomb actually did similar experiments and came up with the following observations:

1. The electrostatic force between two charges varies directly as the product of the two charges. i.e.

$$F \propto Q_1 Q_2 \dots\dots\dots (i)$$

2. The electrostatic force between two charges varies inversely as the square of the separation distance between the charges i.e.

$$F \propto \frac{1}{d^2} \dots\dots\dots (ii)$$

He summarized his observation in what is called the **Coulomb's law**.

It states that *"the force of attraction or repulsion between two electrically charged particles is directly proportional to the magnitude of their charges and inversely proportional to the square of the distance between them"*.

The Coulomb force between two or more charged bodies is the force between them due to Coulomb's law.

Combining equation (i) and (ii),

$$F \propto \frac{Q_1 Q_2}{d^2} \text{ and } F = k \frac{Q_1 Q_2}{d^2}$$

The constant of proportionality  $k$  is called **Coulomb's constant** and depends on the medium in which charged bodies are presented.

$$k = \frac{1}{4\pi\epsilon_0}$$

Therefore the equation becomes

$$F = \frac{1}{4\pi\epsilon_0} \frac{Q_1 Q_2}{d^2}, \text{ where;}$$

- $F$  is the repulsion or attraction force between two charged bodies.
- $Q_1$  and  $Q_2$  are the electrical charges of the bodies.
- $d$  is distance between the two charged particles.

### Example 9.1

Two balloons are charged with an identical quantity and type of charge:  $-6.25 \text{ nC}$ . They are held apart at a separation distance of  $61.7 \text{ cm}$ . Determine the magnitude of the electrical force of repulsion between them. Take

$$k = 9.0 \times 10^9 \text{ N.m}^2/\text{C}^2$$

**Solution**

$$Q_1 = -6.25 \text{ nC} = -6.25 \times 10^{-9} \text{ C}$$

$$Q_2 = -6.25 \text{ nC} = -6.25 \times 10^{-9} \text{ C}$$

$$d = 61.7 \text{ cm} = 0.617 \text{ m}$$

$$\begin{aligned} F &= \frac{1}{4\pi\epsilon_0} \frac{Q_1 Q_2}{d^2} = \frac{9 \times 10^9 \times 6.25 \times 10^{-9} \times 6.25 \times 10^{-9}}{0.617^2} \\ &= 923.5 \times 10^{-9} \text{ N} \end{aligned}$$



**Note:** The negative "-" sign was dropped from the  $Q_1$  and  $Q_2$  values prior to substitution into the Coulomb's law equation. The use of "+" and "-" signs in the equation would result in a positive force value if  $Q_1$  and  $Q_2$  are like charged and a negative force value if  $Q_1$  and  $Q_2$  are oppositely charged. The resulting "+" and "-" signs on  $F$  signifies whether the force is attractive (a "-"  $F$  value) or repulsive (a "+"  $F$  value).

**Example 9.2**

Suppose that two point charges, each with a charge of  $+1.00\text{C}$  are separated by a distance of  $1.00 \text{ m}$ . Determine the magnitude of the force of repulsion between them.

**Solution**

$$Q_1 = 1.00 \text{ C}, Q_2 = 1.00 \text{ C}, d = 1.00 \text{ m}$$

$$\begin{aligned} F &= \frac{1}{4\pi\epsilon_0} \frac{Q_1 Q_2}{d^2} = \frac{9 \times 10^9 \times 1.00 \times 1.00}{1^2} \\ &= 9.0 \times 10^9 \text{ N} \end{aligned}$$

**Exercise 9.1**

**Take  $k = 9.0 \times 10^9 \text{ N}\cdot\text{m}^2/\text{C}^2$  and use it where necessary to answer questions.**

- Two balloons with charges of  $+3.37 \mu\text{C}$  and  $-8.21 \mu\text{C}$  attract each other with a force of  $0.0626 \text{ N}$ . Determine the separation distance between the two balloons.

2. Determine the electrical force of attraction between two balloons with charges of  $+3.5 \times 10^{-7}$  C and  $-2.9 \times 10^{-6}$  C when separated by a distance of 0.65 m.
3. Determine the electrical force of attraction between two balloons that are charged oppositely type the with same quantity of charge. The charge on the balloons is  $6.0 \times 10^{-5}$  C and they are separated by a distance of 0.50 m.
4. A helium nucleus has charge  $+2e$  and a neon nucleus  $+10e$ , where  $e = 1.60 \times 10^{-19}$  C. With what force do they repel each other when separated by  $3 \times 10^{-9}$  m?
5. If two equal charges, each of 1 coulomb, were separated in air by a distance of 1 km, what would be the force between them?
6. Determine the force between two free electrons spaced  $10^{-10}$  m apart. ( $e = 1.60 \times 10^{-19}$  C)
7. What is the force of repulsion between two argon nuclei when separated by  $10^{-9}$  m? The charge on an argon nucleus is  $+18e$ .
8. Two equally charged pith balls are 3 cm apart in air and repel each other with a force of  $4 \times 10^{-5}$  N. Compute the charge on each ball.
9. Two small equal pith balls are 3 cm apart in air and carry charges of  $+3 \times 10^{-9}$  C and  $-12 \times 10^{-9}$  C respectively. Compute the force of attraction.
10. A positive charge of magnitude  $3.0 \times 10^{-8}$  C and a negative charge of magnitude  $4.0 \times 10^{-8}$  C are separated by a distance of 0.02 m. Calculate the force between the two charges and give its direction.

## 9.2 Superposition of forces

### Activity 9.2

To find out the statement of the principles of superposition of force and how it governs interactions of electric fields

1. What do you think superposition of force is?
2. Research from the Internet or text books, the statement of the principle of superposition of forces and how it governs interactions of electric fields.
3. With the help of your teacher, harmonize your findings and write down the notes in your note books

Coulomb's law applies to any pair of point charges. When more than two charges are present, the net force on any one charge is simply the vector sum of the forces exerted on it by the other charges.

If three charges  $Q_1, Q_2, Q_3$  are present, the resultant force  $F_2$  experienced by  $Q_2$  due to  $Q_3$  and  $Q_1$  is given by

$$\vec{F}_2 = \vec{F}_{12} + \vec{F}_{23}$$

Where

$\vec{F}_{12}$  is the force exerted on  $Q_2$  by  $Q_1$

$\vec{F}_{23}$  is the force exerted by  $Q_3$  on  $Q_2$



**Note:** Force is a vector quantity. Hence, the direction of the force must be considered during vector addition. For forces between charges, the direction of the force is determined by whether the force is attraction or repulsion.

The superposition principle (superposition property) states that *for all linear forces, the total force is a vector sum of individual forces*. It holds for linear systems.

The superposition principle is illustrated in the example below.

### Example 9.3

Three charges are arranged as shown in Fig. 9.3. Find the force on the charge  $Q_2$  given that,  $Q_1 = 6.0 \times 10^{-6}$  C,  $Q_2 = 3 \times 10^{-6}$  C and  $Q_3 = -9 \times 10^{-6}$  C when  $Q_1$  and  $Q_3$  are 2.0 m from  $Q_2$ .

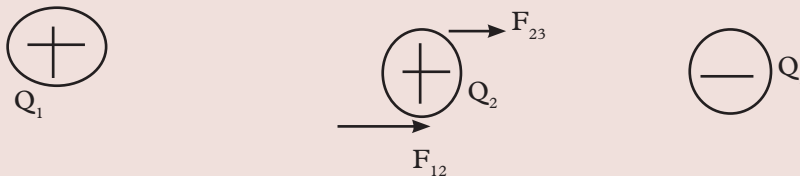


Fig. 9.3: Three charges

### Solution

$$\begin{aligned} F_{12} &= \frac{1}{4\pi\epsilon_0} \frac{Q_1 Q_2}{d^2} = \frac{9.0 \times 10^9 \times 6 \times 10^{-6} \times 3 \times 10^{-6}}{2^2} \\ &= 4.05 \times 10^{-2} \text{ N} \end{aligned}$$

$$\begin{aligned} F_{23} &= \frac{1}{4\pi\epsilon_0} \frac{Q_2 Q_3}{d^2} = \frac{9.0 \times 10^9 \times 3 \times 10^{-6} \times 9 \times 10^{-6}}{2^2} \\ &= 6.075 \times 10^{-2} \text{ N} \end{aligned}$$



Since  $F_{12}$  and  $F_{23}$  are in the same direction,

$$F_2 = F_{12} + F_{23} = 4.05 \times 10^{-2} \text{ N} + 6.075 \times 10^{-2} \text{ N}$$

$$\therefore F_2 = 1.0125 \times 10^{-1} \text{ N}$$

### Example 9.4

Three charges are arranged as shown in Fig. 9.4. Find the force on the charge  $Q_3$  assuming that,  $Q_1$  is  $-9.0 \times 10^{-6} \text{ C}$ ,  $Q_2$  is  $3 \times 10^{-6} \text{ C}$  and  $Q_3$  is  $-6 \times 10^{-6} \text{ C}$  when  $Q_1$  and  $Q_3$  are 2.0 m from  $Q_2$ .

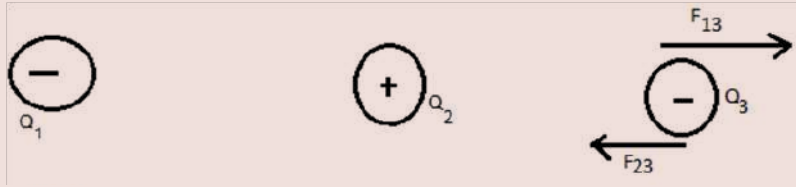


Fig. 9.4: Three charges

$$\begin{aligned} F_{13} &= \frac{1}{4\pi\epsilon_0} \frac{Q_1 Q_3}{d^2} = \frac{9.0 \times 10^{-6} \times 6 \times 10^{-6}}{4} \\ &= 3.0375 \times 10^{-2} \text{ N} \end{aligned}$$

$$\begin{aligned} F_{23} &= \frac{1}{4\pi\epsilon_0} \frac{Q_2 Q_3}{d^2} = \frac{9.0 \times 10^{-6} \times 3 \times 10^{-6}}{2^2} \\ &= 4.05 \times 10^{-2} \text{ N} \end{aligned}$$

$$\begin{aligned} \therefore F_3 &= F_{23} - F_{13} \\ &= 4.05 \times 10^{-2} \text{ N} - 3.0375 \times 10^{-2} \text{ N} \\ &= 1.0125 \times 10^{-1} \text{ N} \end{aligned}$$

### Exercise 9.2

Take  $k = 9.0 \times 10^9 \text{ N m}^2/\text{C}^2$  where necessary.

- Three charges are arranged such that a charge of  $Q_1$  is  $2.0 \times 10^{-6} \text{ C}$ ,  $Q_2$  is  $-1 \times 10^{-6} \text{ C}$  and  $Q_3$  is  $1 \times 10^{-6} \text{ C}$  when  $Q_1$  and  $Q_3$  are 1.0 m from  $Q_2$ . find the force on the charge  $Q_2$ .
- Three point charges are fixed in a straight line. The quantities of charges on each are  $Q_1 = 4.0 \times 10^{-6} \text{ C}$ ,  $Q_2 = 1.0 \times 10^{-6} \text{ C}$  and  $Q_3 = -5.0 \times 10^{-6} \text{ C}$  respectively. The distance between  $Q_1$  and  $Q_2$  is 4.0 cm and the distance between  $Q_2$  and  $Q_3$  is 3.0 cm. What is the approximate force on  $Q_1$  due to the other two charges?



3. Calculate the force experienced by the ball of charge  $-2Q$  in each of the case if  $d$  is 2.0 cm. (See Fig. 9.5)

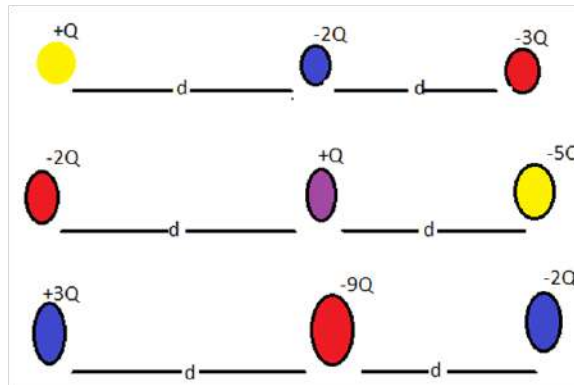


Fig. 9.5: Ball of charges

## 9.3 Electric field

### 9.3.1 Definition of electric field

#### Activity 9.3

#### To define an electric field

##### Materials:

- Internet enabled computer
- Reference books

##### Step

Research from reference books or Internet the definition of an electric field.

We are familiar with the observation that a charged body attracts small pieces of paper, dust, hair etc. The basic law of electrostatics states that like charges repel and unlike charges attract. So a charged body can affect other nearby objects without touching them. This *action at a distance* can be explained by what is called the *electric field* of a charged body.

#### Activity 9.4

#### To demonstrate the electric fields produced by charged bodies

##### Materials:

- Glass dish
- Castor oil
- Electrodes
- Connecting wires

##### Steps

1. Assemble a pair of straight metal wires, called the electrodes, in a shallow

glass dish so that their ends are just covered by a layer of an insulating liquid like castor oil or carbon tetrachloride (Fig. 9.6).

2. Apply a very high potential difference, from a suitable power supply, to the two electrodes so that they have opposite charges.
3. Then sprinkle grass seeds or semolina powder on the surface of the liquid.
4. Observe what happens to the grass seeds or powder and draw the resulting pattern.
5. Repeat the activity with different charges on electrodes and observe the pattern formed.
6. Draw the various patterns and draw the various alignment of the grass seeds.

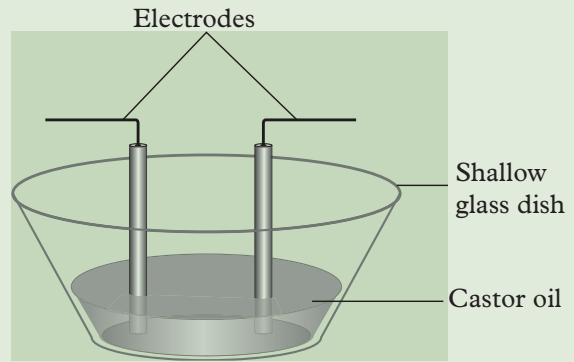


Fig. 9.6: Arrangement to study the electric field

In the above Activity, the seeds acquire induced opposite charges at their ends and align themselves in a particular pattern (Fig. 9.7 (a)). This pattern depends upon the charge on the electrodes.

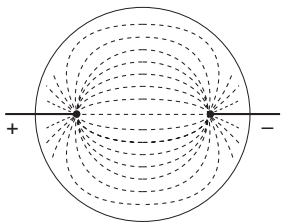
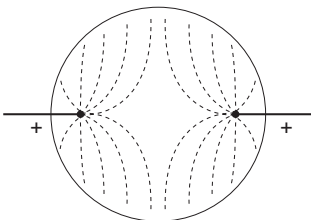
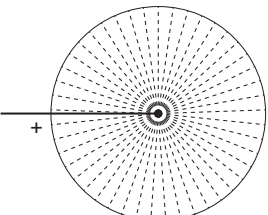
- (a)  Two straight wires dipped into the liquid and connected to the opposite polarities of a high voltage power supply (Fig. 9.7 (a)).
- (b)  Two straight wires dipped into the liquid, both connected to the same positive potential terminals (Fig. 9.7 (b)).
- (c)  A straight vertical wire dipped into the liquid having a high positive charge (Fig. 9.7 (c)).

Fig. 9.7: Electric fields due to different shapes of electrodes

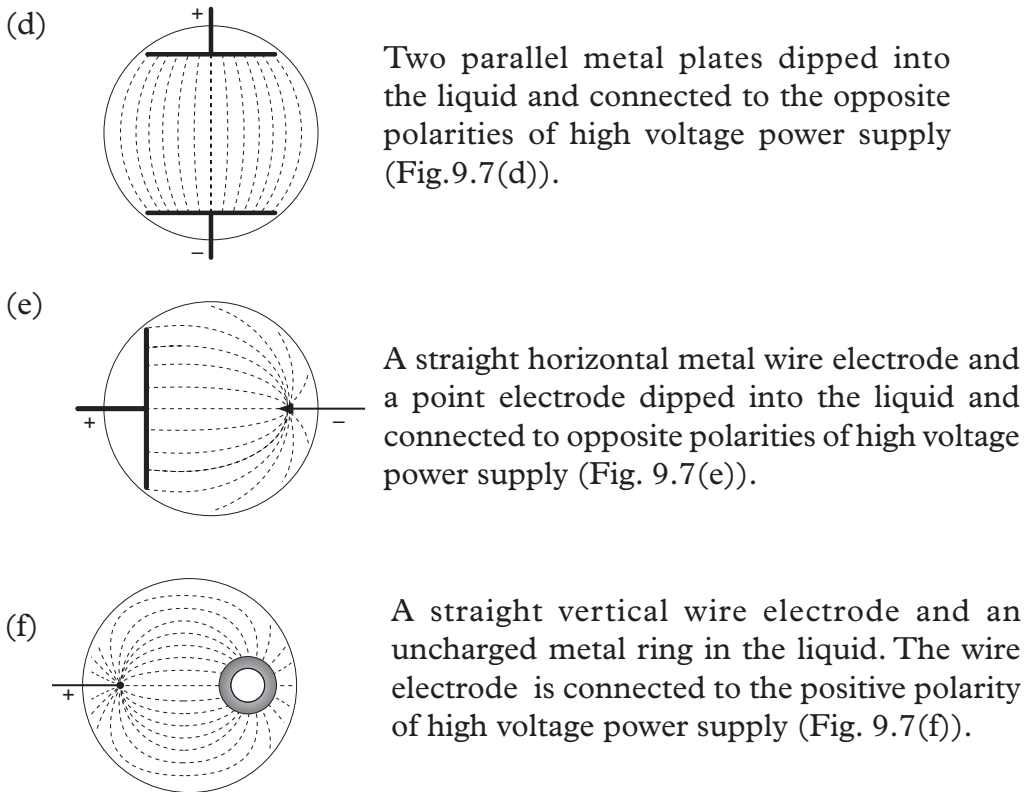


Fig. 9.7 (d) to (f): Electric fields due to different shapes of electrodes

The above alignment of seeds depict the electric field produced in different arrangements.

An electric field is as the region or space surrounding a charge. In this region, another charged body may move away from or towards the charged body due to the electric field. In Fig. 9.8, P is a positively charged body and N is a negatively charged body producing an electric field. If another light charged body T is introduced in this field, the body T may experience a force away from P or towards N.

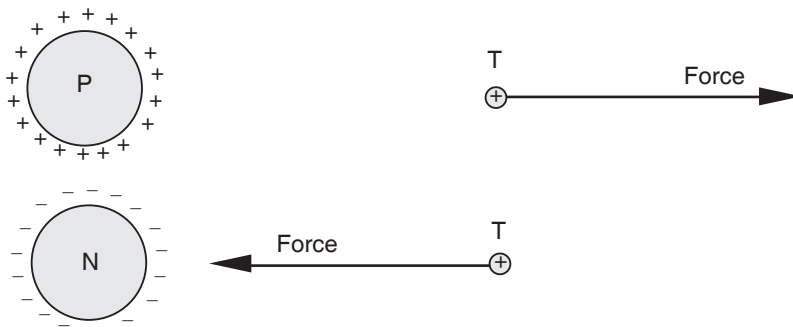


Fig. 9.8: Force between charges in an electric field

If a body is positively charged and has a charge of 1 coulomb, it is called a *test charge* or a *unit positive charge*. A unit positive charge experiences a force in the electric field.

An electric field is *defined as the region around a charged body where electrostatic force due to the charges is experienced*.

### 9.3.2 Direction of electric field

#### Activity 9.5

To determine the direction of an electric field and the line of force

#### Materials:

- Books or the Internet

#### Steps

1. Research from books and internet the definition of the direction of an electric field line and electric line of force.
2. Discuss with your partner the properties of electric lines of force.

Fig. 9.9 shows the direction of force acting on the test charge, indicated by the arrow head. The force is either away from or towards the charge which creates the field. *The direction of the electric field* at a particular point is defined as *the direction in which a unit positive charge is free to move when placed at that point*. It should be noted that the force experienced by a negative charge will be in an opposite direction to that of the electric field (Fig. 9.9).

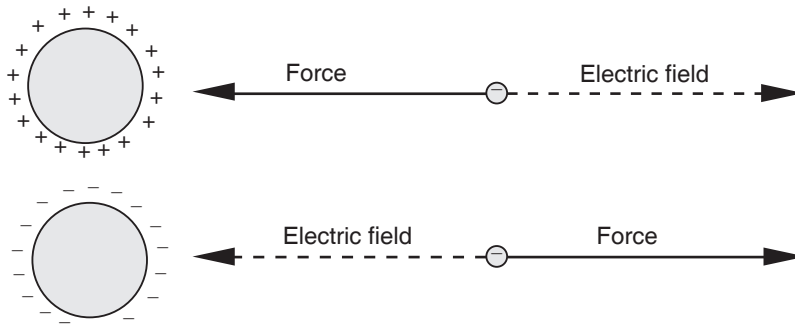


Fig. 9.9: Force acting on a negative charge in an electric field

### 9.3.3 Electric lines of force

In an electric field, the electric force exists at all points. The test charge, i.e., the unit positive charge will be forced to move in a particular direction when placed at any point in the field. The path along which a unit positive charge would tend to move in the electric field is called the *electric field line* or *the electric line of force*. If the path is a curve, the tangent at any point gives the direction of the electric field (Fig. 9.10).

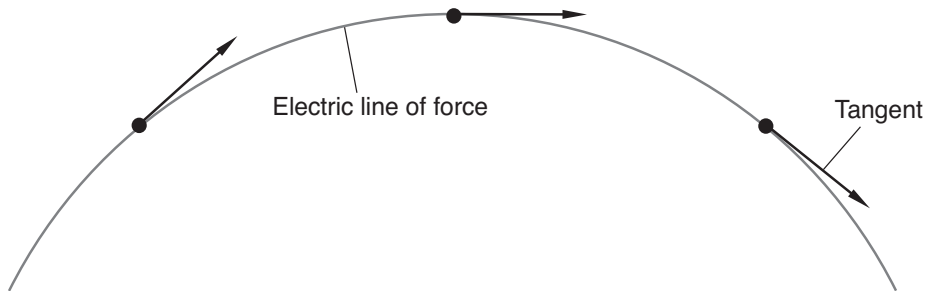


Fig. 9.10: An electric field line.

A line of force may be traced by placing a unit positive charge at any point and allowing it to move throughout in the direction of the force acting on it. This is similar to the magnetic line of force in the magnetic field created by a magnet.

### Properties of electric lines of force

1. Lines of force start at  $90^\circ$  from the positive charge and end on the negative charge at  $90^\circ$ .
2. No two lines of force can ever cross each other.
3. The field lines are 'elastic', i.e., the lines tend to contract or expand so that they never intersect each other.

## 9.4 Electric field intensity

### 9.4.1 Definition of electric field intensity

#### Activity 9.6

To show the strength of an electric field varies with quantity of charge and distance from the charge.

#### Materials:

- a clamp and a stand
- polythene rod
- pith ball
- a string

#### Steps

1. Suspend a pith ball with a string on a clamp ( Fig. 9.11). Charge it by rubbing it with a dry cloth.
2. Charge a polythene rod by rubbing it with a cloth.
3. Hold the pith ball firmly with an insulating material and bring the charged polythene rod close to the suspended pith ball.

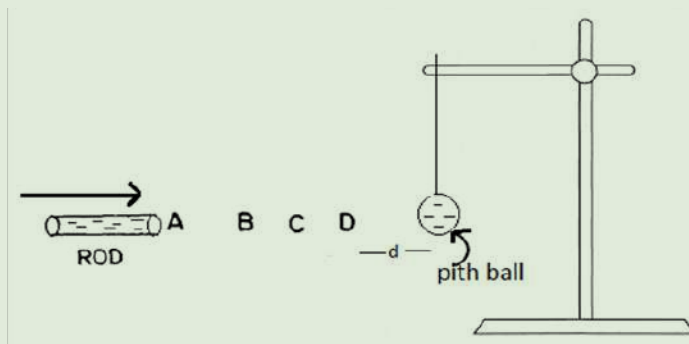


Fig. 9.11: Demonstrating strength of electric field.

4. Measure the distance and observe what happens when you release the pith ball.
5. Repeat steps 3 and 4 but this time bring the polythene rod more closely to the pith ball. Compare your observations this time and your observations in step 4.
6. Charge the rod more strongly and repeat steps 3 and 4, trying as much as possible to maintain the same distance. Compare your observations in steps 3, 4 and 5. Comment on the composition.
7. Based on your observations in this activity, make a conclusion on how the strength of the electric field varies with the
  - (a) Quantity of charge.
  - (b) Distance from the charge.

Electric field intensity is the measure of the strength of an electric field at a specified point. It is defined as the *electrostatic force per unit charge experienced by a test charge placed at a specified point in an electric field*.

$$\text{Thus, Electric field intensity, } E = \frac{\text{Electrostatic force}}{\text{Charge}} \text{ or } E = \frac{F}{Q}$$

Its SI unit is Newtons per coulomb (N/C) or volts per metre (V/m).

### 9.4.2 Factors that determine the magnitude of electric field intensity

#### 1. The distance of a point in the electric field from the charge

Electric field intensity decreases with the increase distance away from the charge. For example, the electric field intensity at point A in the electric field of charge Q is greater than that at point B in Fig. 9.12.

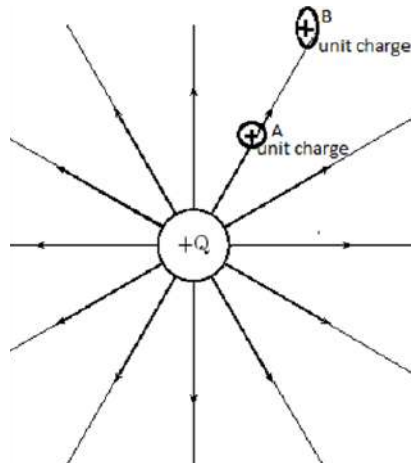


Fig. 9.12: Variation of electric field strength with distance.

## 2. The quantity of charge

Consider a unit charge,  $q$  at a fixed distance,  $d$  from charge,  $Q$ . The force experienced by the unit charge due to charge,  $Q$  increases when the quantity of charge,  $Q$  is increased.

Therefore, electric field intensity point at a point is directly proportional to the quantity of charge.

Consider a point charge  $q$  in the field of charge  $Q$ , a distance  $d$  from  $Q$  (Fig. 9.13).

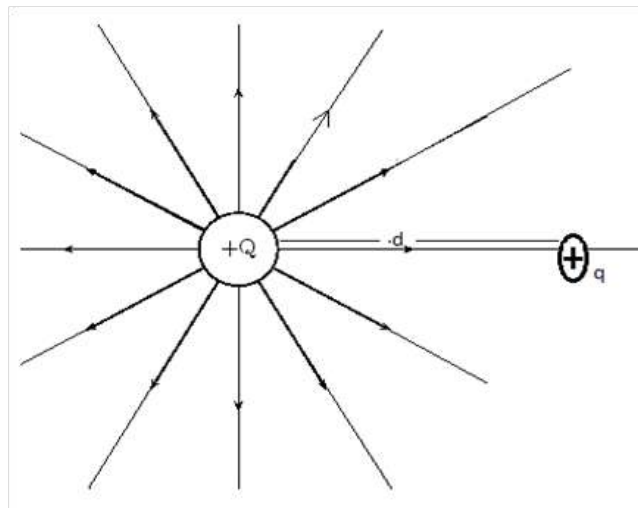


Fig. 9.13 A point charge in an electric field.

Applying Coulomb's law, the force between the charge ( $Q$ ) and the unit charge ( $q$ ) is given by

$$F = \frac{1}{4\pi\epsilon_0 d^2} \times \frac{Qq}{d^2}$$

Thus, the electric field intensity = force exerted on unit charge  $q$  by charge  $Q$  given by

$$\begin{aligned} E &= \frac{\text{Force exerted}}{\text{Charge}} \\ &= \frac{Qq}{4\pi\epsilon_0 d^2 \times q} \\ &= \frac{Q}{4\pi\epsilon_0 d^2} \quad (\text{on crossing out } q) \end{aligned}$$

We can also get an expression for electric field intensity in terms of electric field potential ( $V$ ) as follows:

**Electric field potential ( $V$ )** is defined the **work done in moving a unit charge through a distance ( $d$ ) in an electric field.**

$$\text{Electric field potential, } V = \frac{\text{Work done}}{\text{Charge (Q)}} = \frac{\text{Force (F)} \times \text{Distance (d)}}{\text{Charge (Q)}}$$

$$\text{But, } \frac{\text{Force (F)}}{\text{Charge (Q)}} = \text{Electric field intensity (E)}$$

Thus, Electric field potential,  $V = \text{Electric field intensity (E)} \times \text{distance (d)}$

$$\text{Hence, Electric field intensity (E)} = \frac{\text{Electric field potential (V)}}{\text{Distance (d)}} \Rightarrow E = \frac{V}{d}$$

Thus, other units of electric field intensity are **volts per metre**.

### Example 9.5

A force of 3 N is acting on the charge 6  $\mu\text{C}$  at any point. Calculate the electric field intensity at that point?

### Solution

Given: Force  $F = 3 \text{ N}$ , Charge  $q = 6 \mu\text{C}$

$$\begin{aligned} \text{The Electric field is given by, } E &= \frac{F}{q} = \frac{3 \text{ N}}{6 \times 10^{-6} \text{ C}} \\ &= 5 \times 10^5 \text{ N/C.} \end{aligned}$$



**Example 9.6**

Find electric field at a distance of  $r = 10^{-10}$  m from the nucleus of Helium atom?

**Solution**

Given: Charge in nucleus,  $q = 2 \times 1.6 \times 10^{-19}$  C =  $3.2 \times 10^{-19}$  C.

Distance  $d = 10^{-10}$  m

$$\begin{aligned} \text{The formula of electric field is given by; } E &= \frac{kq}{d^2} = \frac{9 \times 10^9 \times 3.2 \times 10^{-19}}{(10^{-10})^2} \\ &= 28.8 \times 10^{10} \text{ N/C} \\ &= 2.88 \times 10^{11} \text{ N C}^{-1} \end{aligned}$$

**Exercise 9.3**

For questions 1 - 5, choose the correct response from the choices given.

Take  $k = 9.0 \times 10^9 \text{ N.m}^2/\text{C}^2$  where necessary.

- Region around a charge  $q$  in which it exerts force on a test charge is called
 

A. Electric field intensity	B. Electric force
C. Electric field	D. Coulombs force
- Field lines always emerge from.
 

A. negative charge	B. can be both charges
C. the central point of both charges	D. positive charge
- Direction of free test charge will be
 

A. Direction of electric intensity	B. Direction of coulombs force
C. Direction of magnetic intensity	D. Direction of protons
- Spacing between field lines shows
 

A. Their direction	B. Their position
C. Both a and b	D. Their strength
- Electric field intensity is
 

A. a base quantity	B. a scalar quantity
C. A and B both	D. a vector quantity
- A uniform electric field of magnitude 30 N / C is directed downward. What is the magnitude and direction of the force on:

- (a) +4.0 C charge placed in this electric field  
 (b) -3.0 charge placed in this electric field
7. A charge of magnitude  $-3.0 \times 10^{-6}$  C is moved through a potential difference of 80 volts. Calculate the work done on the charge.

## 9.5 Electric field patterns

### Activity 9.7

To draw electric field patterns.

#### Materials

- Internet
- Reference books

#### Steps

Research and draw electric field patterns of:

- (a) A point positive charge and point negative charge.  
 (b) Two positive charges near each other and negative charges.  
 (c) Two equal unlike charges.

The electric field pattern around a charged body depends on whether the body is completely isolated or is in the presence of other bodies. The following are some examples of electric field patterns for isolated and non-isolated bodies.

1. Fig. 9.14(a) shows an isolated positive point charge. The field lines are radially outwards from the positive charge.
2. Fig. 9.14(b) shows an isolated negative point charge. The field lines are radially inwards towards the negative charge.

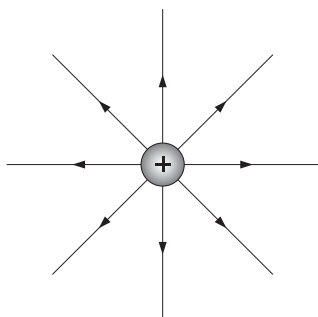


Fig. 9.14(a): Isolated positive point charge

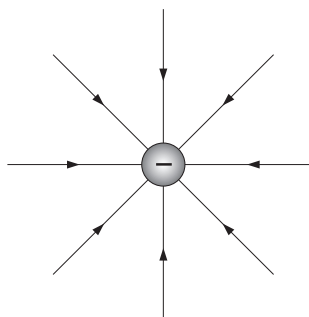


Fig. 9.14(b): Isolated negative point charge

3. Fig. 9.16 shows two equal positive point charges. The field lines start radially outwards from each charge. The resultant field is due to the electric field produced by each charge.

A point N lies midway between the two charges, on the line joining them. Here the resultant force acting on the unit positive charge is zero and is called a *neutral point*. A neutral point *in an electric field is one where the resultant force acting on the unit positive charge is zero* (Fig. 9.15). Force due to A = force due to B. i.e.  $F_A = F_B$   
No field lines exist at the neutral point.

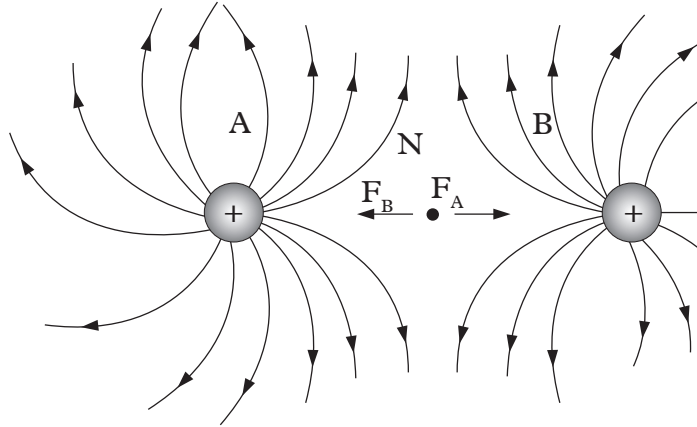


Fig. 9.15: Two equal positive point charges

4. Fig. 9.16 shows two equal unlike point charges. The field lines start from the positive charge and end on the negative charge. In this case, there is no neutral point as a unit positive charge placed at any point experiences a force.

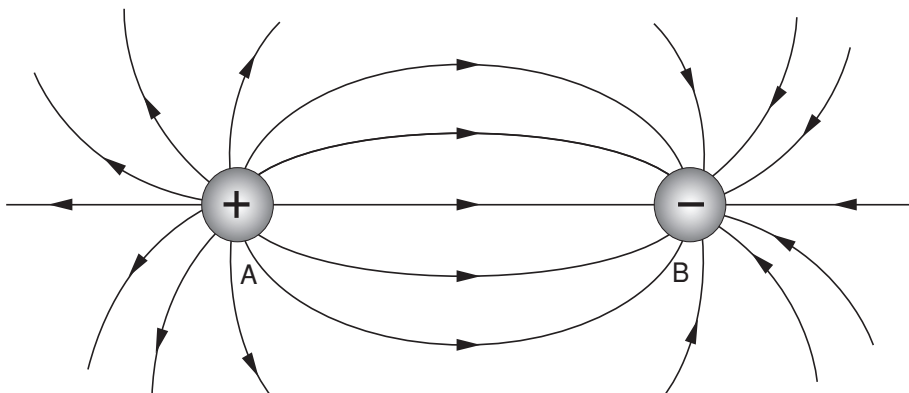


Fig. 9.16: Two equal unlike point charges

5. Fig. 9.17 shows two unequal positive point charges. The neutral point N is more closer to the weaker charge.

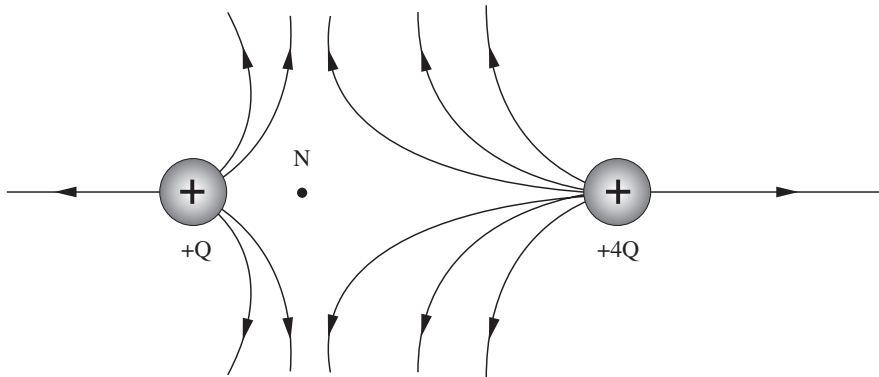


Fig. 9.17: Electric field between unequal positive charges

6. Fig. 9.18 shows a positive point charge and a straight metal plate with negative charge.

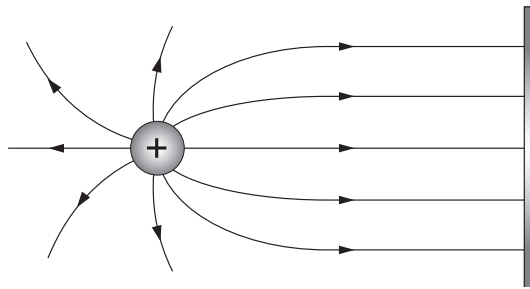


Fig. 9.18: A positive point charge and a negative metal plate

7. Fig. 9.19 shows a positive point charge and an uncharged ring placed in the electric field. The metal ring placed near the positive charge gets charged by electrostatic induction. The field lines are as shown in Fig. 9.19. The field lines do not pass through the conductor. The conducting ring acts as an electric shield for the space enclosed by the ring.

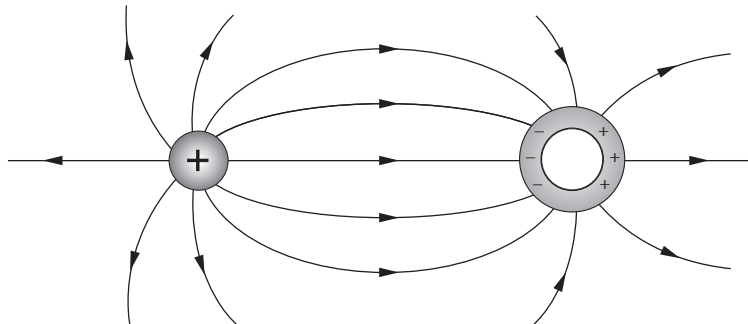


Fig. 9.19: A positive point charge and uncharged ring

8. Fig. 9.20 shows two parallel metal plates having opposite charges and placed close together. In this case the field lines are parallel except at the edges. If the field lines are parallel, the *electric field is uniform*.

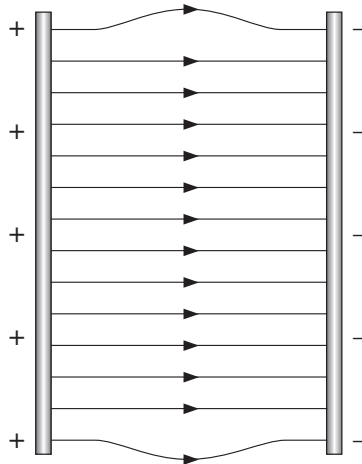


Fig. 9.20: Two parallel metal plates having opposite charges

### Unit summary and new words

- The force between two point charges is...
  - (i) directly proportional to the magnitude of each charge  $Q_1, Q_2$ .
  - (ii) inversely proportional to square of the separation between their centers (d). This relationship is known as Coulomb's Law. As an equation it is usually written in one of two form.
 
$$F = k \frac{Q_1 Q_2}{d^2} \quad \text{or} \quad F = \frac{1}{4\pi\epsilon_0} \frac{Q_1 Q_2}{d^2}$$
    - (i) When two charges have the same sign, their product is positive, which means the action is repulsive.
    - (ii) When two charges have the opposite sign, their product is negative, which means the action is attractive..
- An electric field is a region where a charged body experiences an electrostatic force.
- The direction of the electric field is the direction in which a unit positive test charge would move to when placed at that point.
- An electric line of force is the path along which a unit positive charge would tend to move in the electric field.

- The electric field is uniform if the field lines are parallel.
- Electric lines of force do not cross each other.
- Electric lines of force start from positive charge and end in the negative charge.

## Unit Test 9

For questions 1 - 4, select the correct response from the choices given.

Take  $k = 9.0 \times 10^9 \text{ N m}^2/\text{C}^2$  where necessary.

- When distance from center is doubled then electric field strength will
 

<b>A</b> decrease by factor of four	<b>B</b> increase by factor of four
<b>C</b> will be same	<b>D</b> decrease by factor of two
- Electric force on a dust particle having charge equal to  $8 \times 10^{-19} \text{ C}$  when plates are separated by distance of 2 cm and have a potential difference of 5 kV is
 

<b>A</b> $2 \times 10^{-13} \text{ N}$	<b>B</b> 3 N
<b>C</b> 5 N	<b>D</b> 20 N
- Electric field strength can be defined as
 

<b>A</b> $E = \frac{Q}{F}$	<b>B</b> $E = \frac{W}{F}$
<b>C</b> $E = \frac{F}{Q}$	<b>D</b> $E = \frac{P}{Q}$
- Which statement is correct about the conditions in a uniform electric field?
  - All charged particles experience the same force.
  - All charged particles move with the same velocity.
  - All electric field lines are directed towards positive charges.
  - All electric field lines are parallel

5. Fig. 9.21 below shows electric field lines around a charged metal sphere (in air)

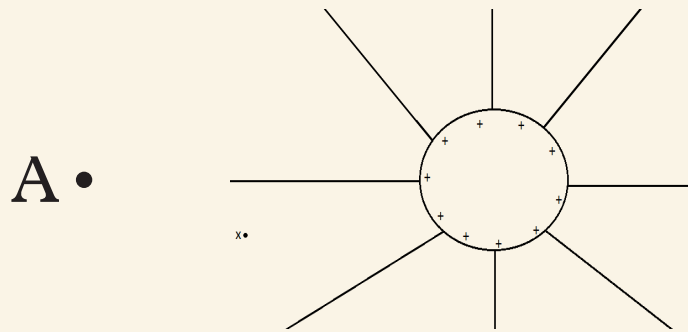


Fig. 9.21:

Copy the diagram. Draw an arrow on each line to show the direction of the electric field if a:

- (a) positive point charge is placed at A.
  - (b) negative point charge is placed at A.
6. A small positive charge is placed in the electric field of a large charge . Both charges experience a force  $F$ . derive the formula for electric field strength of the charge at the position of charge.
  7. A charge of magnitude  $-4.0 \times 10^{-6}$  C is moved through a potential difference of 70 volts. Calculate the work done on the charge.
  8. What is the magnitude of the electric field intensity at a point in the field where an electron experiences a 1.0 -newton force (electrons have a charge of  $-1.6 \times 10^{-19}$  C)?
  9. Fig. 9.22 shows a metal ball with a charge of  $1.6 \times 10^{-19}$  C at rest in an electric field with an intensity of  $15.0 \times 10^{20}$  N per coulomb. What is the weight of the ball?

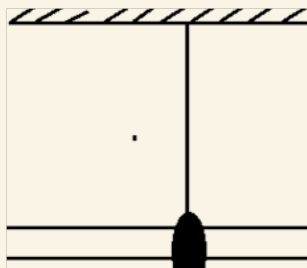


Fig. 9.22: Charged metal ball in electric field

10. If the intensity of the electric field at point P in Fig. 9.23 is  $-3.5 \times 10^4$  N/C, what is the magnitude of the electric force acting on an electron at P? (Electrons have a charge of  $-1.6 \times 10^{-19}$  C)

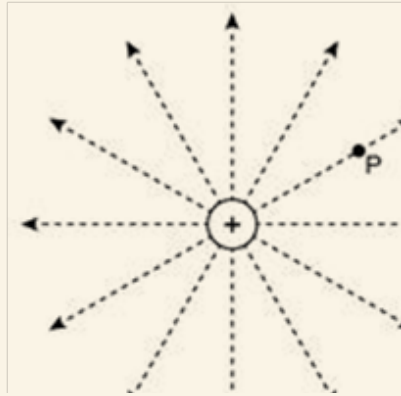


Fig. 9.23: Electric field

11. You have an electric field with an intensity of  $18 \text{ N/C}$  at a distance of  $6.0 \text{ m}$ . What is the voltage?
12. Fig. 9.24 shows a point charge in an electric field. If a point charge has a charge of  $+3.2 \times 10^{-19} \text{ C}$ , what is the magnitude of the electric force acting on the point charge located in an electric field with an intensity of  $5.0 \times 10^3 \text{ N/C}$ ?

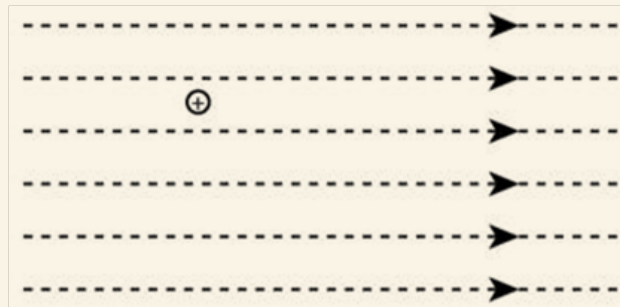


Fig. 9.24: Point charge in electric field

13. Two parallel oppositely charged plates are  $5.1 \text{ cm}$  apart. The potential difference, in volts, between the plates is  $44.6 \text{ V}$ . Find the electric field strength between them.
14. If it takes  $88.3 \text{ J}$  of work to move  $0.721 \text{ C}$  of charge from a positive plate to a negative plate, what is the potential difference (voltage) between the plates?



**Key Unit Competence**

By the end of the unit, the learner should be able to analyse and carry out a simple electric installation.

**Learning objectives****Knowledge and understanding**

- Describe electric circuit diagrams.
- Differentiate between surface wiring and conduit wiring.
- Identify components used in electrical installation.
- Explain protecting electric devices and their installation.
- Identify different lamps.

**Skills**

- Describe symbols used in electrical engineering drawing.
- Describe the cable by type and size used for lightning arrestor, lighting and socket outlets.
- Carry out simple surface wiring for a residential house using appropriate tools.
- Evaluate different electrical protective devices.
- Explain the functioning of circuit breakers and fuses in electrical circuits.

**Attitude and value**

- Appreciate applications of electricity.
- Develop responsible behavior towards electrical installation.
- Develop responsible behaviour for protection against dangers associated with electricity.
- Acquire skills for identifying problems in electric circuits.



## Introduction

### Unit Focus Activity

#### Materials:

- Manila paper
- Geometrical set

#### Steps

1. Think of a house in the school compound or at home. Using a manila paper, sketch a plan of how you can carry out a successful electrical wiring.
2. Highlight the electrical components you may need to complete the wiring.
3. In your view, do you need earth connection? Describe how it is installed.
4. Discuss how people can be safe from hazards caused by electricity.

Electrical installation in your home is a skill you can acquire. Knowing how circuits work and what can be done with them is useful knowledge. Wiring in a residential houses is not that complicated, but it can be dangerous. Proper understanding and caution are required. In this unit, we are going to learn how electric installation in houses is done.

## 10.1 Standard symbols for electrical installation

### Activity 10.1

To identify standard symbols for electrical installation

#### Materials

- Different fuses
- A switch
- Chart showing standard symbols for electrical installation.
- A socket
- Bulb

#### Steps


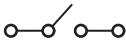
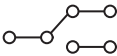

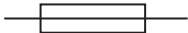

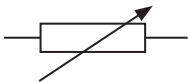
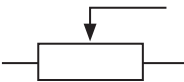
1. Take the electrical devices provided to you. Draw their symbols as used in electrical circuit.
2. Tell your group members the uses of each electrical device provided.
3. Now, take the chart provided to you. Compare your drawings of the symbols with the ones on the chart. How accurate were your drawings?
4. Take your group members through other electrical symbols shown on the chart.

Most of the electrical devices are made in different styles, appearances and colours according to users' requirements. However, standard electrical symbols are used to represent various electrical and electronic devices in schematic diagrams of electrical or electronic circuits. They are easy to understand.

The following table lists some basic electrical symbols.

Table 10.1

Device	Symbol	Device	Symbol
Cell		Battery	
Lamp		ac supply	
Ammeter		Voltmeter	
Galvanometer		Transformer	

Heating element		Switch	
2-way switch		Bell	
Fuse		Fixed resistor	
Variable resistor (rheostat)		Potentiometer	

## 10.2 Electrical lamps and fuses

### Activity 10.2

To observe and describe different types of electrical lamps used for lighting

#### Material

- Different types of electrical lamps
- Internet
- Reference books

#### Steps

1. Take different electrical lamps provided to you and discuss their appearances and structures. What differentiates them from each other?
2. Identify which electrical lamps are more efficient for use at homes.
3. Conduct a research on types of electrical lamps used for lighting.
4. In your research, find out the structure and the gases used in the lamps (if any).
5. Present a summarized report of your findings to the whole class through your group secretary.

An **electrical lamp** is a light emitting electrical device used in electric circuits, mainly for **lighting** and **indicator** purposes. The construction of an electrical lamp is quite simple. It has a filament surrounded by a transparent glass. The filament of the lamp is usually made of tungsten since it has high-melting point.

When current flows through lamp, the tungsten filament glows without melting, producing light energy.

### 10.2.1 Types of lamps

There are three main categories of electrical lamps namely: **incandescent lamp**, **LED lamps** and **gas-discharge lamps**.

#### (a) Incandescent lamps

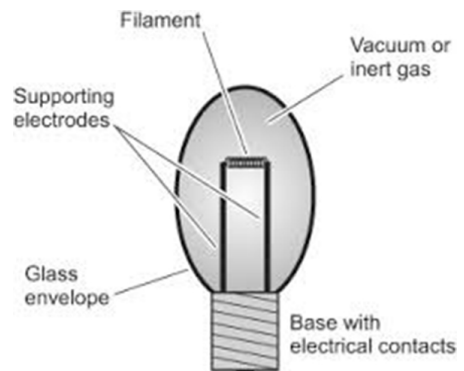
These are lamps which produce light from a filament heated white-hot by an electric current. They are also known as tungsten lamps.



*Fig. 10.1: An incandescent lamp*

These lamps are often considered the least *energy efficient type of electric lighting*. They are commonly found in residential buildings. Although inefficient, incandescent lamps possess a number of advantages: *they are cheap, turn on instantly, are available in a huge array of sizes and shapes and provide a pleasant, warm light with excellent colour rendition.*

An example of incandescent lamps is a vacuum lamp. As the name suggests, the vacuum lamp has the glass enclosing the tungsten filament has no gas in it. It has a vacuum. The tungsten filament is heated to a temperature at which visible light is emitted. The light from the low temperature lamps appear reddish yellow while that from the high temperature lamps has a white appearance. The filament acts as an electrical filament resistor, that dissipates power proportional to the product of the voltage applied and the current through the filament. When the power supplied is sufficient to raise the temperature to above 1 000 K, visible light is produced. As the power dissipated is increased, the amount of light produced increases.



*Fig. 10.2: Vacuum lamp*

### (b) LED lamps

A **LED lamp** is made using **light emitting diodes (LED)**. An LED consists of a junction diode made from a semi conductor material usually **gallium arsenide phosphide**. When current is passed through the diode, it emits light. LED lamps are *cheap* and *highly efficient* because they emit almost no heat.



Fig. 10.3: LED lamp

### (c) Gas-filled lamps

Gas-filled lamps produce light from an **incandescent filament operated in an inert gas atmosphere**. The inert gas suppresses the evaporation of the tungsten filament, increasing the lifetime of the lamp and allow the lamp to operate at higher temperature. The commonly used gases are neon, argon xenon, sodium, mercury. The cost of gas-filled lamps depends on the gases used. For instance, the one filled with xenon is more expensive due to its low natural abundance.

The advantage of the higher atomic weight gases is that they suppress the evaporation of the tungsten filament more effectively than the lower weight gases. This allows the filament of gas filled lamps to run at temperature up to 3200 K and achieve reasonable life times. The light from these lamps has a high blue content giving the light a pure white appearance.

The *disadvantage* of a gas filled lamps is that *they require more power to achieve the same temperature than incandescent lamps*.



Fig. 10.4: Gas filled lamps

### Safe energy!

Use energy saver lamps on lighting system in your homes to minimise electricity bills.

## 10.2.2 Fuses and circuit breakers

### (a) Fuses

#### Activity 10.3

To find out the function of a fuse and interpret power ratings of fuses

#### Material

- Fuses of different rates

#### Steps

1. Tell your class partner what a fuse is and its function in an electrical circuit.
2. Keenly observe the fuses provided to you. Check and record their voltage and current ratings.
3. Determine the amount of the current allowed by each fuse to pass through without breaking.

A fuse is a **short thin piece of wire of low melting point**. The wire melts as soon as the current through it exceeds its rated value. Fig. 10.5 shows pictures of fuses.



Fig. 10.5: A fuse

Fuses are usually fitted in all electrical circuits to **prevent dangerously large currents from flowing**. They **melt** or “**blow off**” and stops the flow of current hence protecting the electrical appliances against the risk of fire caused by the heat. The fuse should be therefore fitted on the **live wire**.

## Fuse rating

Fuse rating is the current needed to blow (melt) the fuse. It is usually printed on the side of the fuse. It is usually defined in ‘amperes’, which are the unit of measuring electrical current (see Fig.10.6)

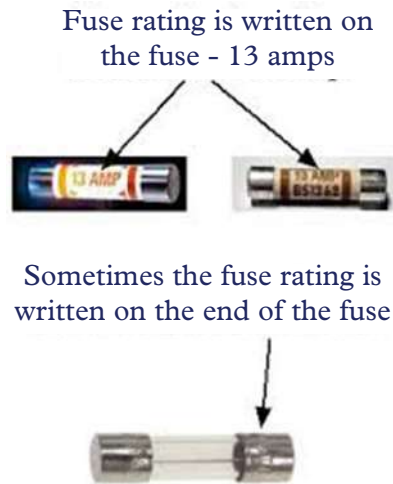


Fig. 10.6: Fuse rating

The fuse used in any electrical appliance should be of a value just slightly higher than the normal current required by the appliance. The common standard values of available fuses are **2 A**, **5 A** and **13 A**, although **1 A**, **3 A**, **7 A** and **10 A** fuses are also made. If the power rating of an electrical appliance is '**2 000 W**, **250 V**', the required current through it is 8 A. The correct fuse to protect the appliance is 10 A. Similarly if the required current for an appliance is 4 A, the correct fuse to be used is 5 A. The required current for any appliance should be less than the rated fuse used in the circuit.

### (b) Circuit breakers

#### Activity 10.4

To describe the working of circuit breakers

#### Materials

- School circuit breaker
- Internet
- Reference books

#### Steps

1. With the permission of your teacher, switch on and off the circuit breaker. What do you notice? Explain.
2. Tell your group members what a circuit breakers is and discuss how it works.
3. Do research from the internet or reference books on how a circuit breaker works.
4. Share your findings to the whole class.



A circuit breaker (Fig. 10.7) is an automatically operated electrical switch designed to protect an electrical circuit from damage caused by either excess current, overload or short circuit.



Fig. 10.7: Circuit breaker

The basic function of a circuit breaker is to **put off the circuit to discontinue current flow after a fault has been detected**. Unlike a fuse which operates once and then must be replaced, a circuit breaker can be reset (either manually or automatically) to resume normal current flow.

### Exercise 10.1

- Table 10.2 shows standard symbols for electrical installation. Fill in the appropriate name or symbol.



	Name	Standard symbol
(a)	Bulb/lamp	
(b)		—       —
(c)	Fuse	
(d)		
(e)	Capacitor	
(f)	D.C Voltage	
(g)		
(h)	Circuit breaker	

Table 10.2

2. Explain why tungsten is used in lamps and not any other metal.
3. What is a fuse? Explain its function in an electrical circuit.
4. A microwave is rated 1 500 W, 240 V. What is the appropriate fuse used in its circuit?
5. What is a circuit breaker? Explain how it functions.
6. Differentiate between a fuse and a circuit breaker.

### 10.3 Types of electrical cables and their sizes

#### Activity 10.5

To find out the types of electrical cables and their standard sizes

#### Materials

- Electrical cables
- Internet
- Reference books

#### Steps

1. Remove the outer jacket of the cable provided to you. How many wire are there? Write down their colours.
2. Suggest the name of each wire in the cable.
3. Now conduct a research, find out how the wire are connected to the electrical application and the sizes of the cables that are there.

More often than not, the term wire and cable are used to describe the same thing, but they are actually quite different. A wire is a single electrical conductor whereas a cable is a group of wires covered in a sheath.

A cable usually has three wires namely the *live wire* (L), *neutral wire* (N) and *Earth wire*.

Fig. 10.8 shows a cable with the live, neutral and earth wires.

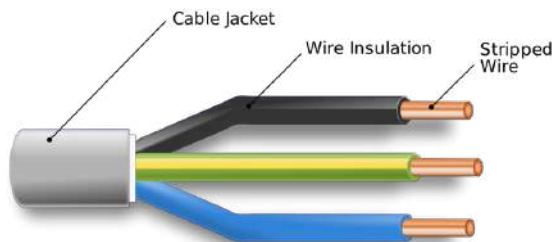


Fig. 10.8: Electrical cable

The domestic supply in Rwanda is mainly 240 V ac with a frequency of 50 Hz. This is supplied by two cables from a local sub-station (for example; Kigoma Substation) to different homes, industries and offices for consumption. Let us now learn these cables in details.

### 10.3.1 Live (L), neutral (N) and earth (E) wires

The live wire may be likened to the positive terminal of a cell or a battery and the neutral wire to the negative terminal (Fig. 10.9 (a) and (b)).

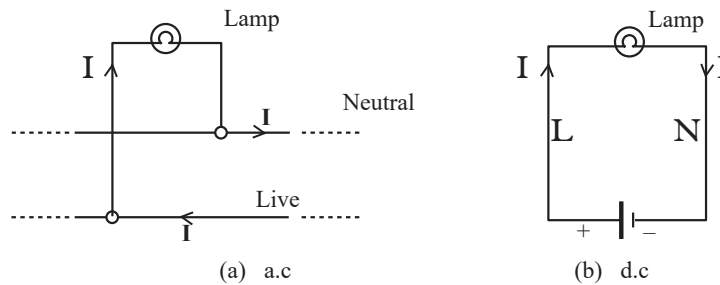


Fig. 10.9: Live and neutral wires

All electrical appliances need a live and a neutral wire to form a complete circuit from the power supply through the appliance and back to the power supply. The **live wire** delivers the current to the appliance. It is dangerous, because it is capable of giving electric shocks, if handled carelessly. *Switches in a circuit should be fitted in the live wire*, so that when the switch is off, the high voltage is disconnected from the appliance. The current returns to the supply through the **neutral wire**. Some electrical appliances have a third wire known as the **earth wire** (E) for safety (is discussed later in the unit).

### 10.3.2 Colour codes for the wires used in house circuits

The insulation, usually of plastic, on the three wires of a cable is distinctively coloured to denote the live, neutral and earth wires. The basic idea of using different colours is to easily identify the wires so that correct connections are made with care. The present international convention is *brown* for **live**, *blue* for **neutral** and *green* with *yellow* stripes for **earth**. Electrical wiring should be checked to ensure that the earth wire lead to (connected to) the metal case of the appliance.

### 10.3.3 Standard size of electrical cables

Electrical cables come in different sizes. It is therefore important to select appropriate sizes ( a process called *sizing*) for electrical power cable conductors.

The proper sizing of cables is important to ensure that the cable can:

1. Operate continuously under full load without being damaged.
2. Provide the load with a suitable voltage (and avoid excessive voltage drop).
3. Withstand the worst short-circuit current flowing through the cables.

Methods of cable sizing differ across international standards and some standards emphasize certain things over others. However, the general principles that underpin

cable sizing calculation do not change. When sizing a cable, the following general process is typically followed.

1. Determine the minimum cable size based on continuous current carrying capacity.
2. Determine the minimum cable size based on voltage drop consideration.
3. Gather data about the cable, its installation condition, the load that it will carry etc.

Table 10.3 shows cross-sectional area, maximum current capacity and voltage drop of some electrical cables.

Table 10.3

Cable Cross Sectional Area (mm <sup>2</sup> )	Max Current Capacity (A)	Volt Drop (mV/A/m)
1.0	14.0	38.0
1.5	18.0	25.0
2.5	25.0	15.0

An electrical cable can be fitted to a plug on one side and the other side to three electrical appliances like electrical iron, immersion heater or refrigerator.

Fig. 10.10 shows a 3-pin plug. It is usually marked with letters L, N and E to stand for live, neutral and earth respectively.

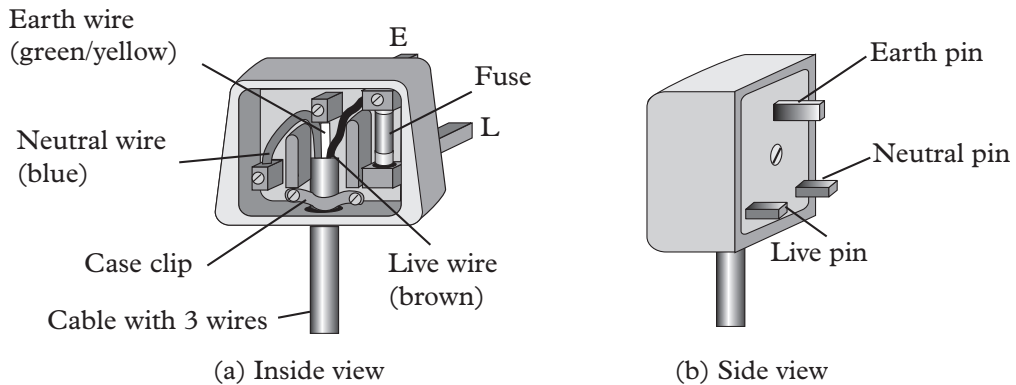


Fig. 10.10: 3-pin plug

Note that the earth pin is slightly longer than the other two pins and that the live pin is on the right hand side of the plug when connected to the socket.

### 10.3.4 Earth connection

The earth wire connects the metal case of an appliance (e.g. an electric iron) to the **ground and prevents it from** becoming *live*, if a fault develops. If, for example, the cable insulation wears out due to the heating effect of the current, there are chances that a few fine strands of the bare live wire could touch the metal case. When such a fault occurs, a current flows through the live wire and the earth wire in series. The **fuse in the live wire will blow and cut off the power supply**. If on the other hand, there was no earth wire connection, a person touching the metal case would get an electric shock.

In appliances like television set, record player, etc. the outer case is not metallic and hence 2-pin plugs are sufficient. It is risky to use a 2-pin plug with an appliance which has an outer metal case because charges may fail to leak to ground and the whole appliance becomes live.

### 10.3.5 Short circuits

If a few strands of the fine bare live wire touch, by chance, those of neutral wire, a large current can flow between the live and the neutral wires of the supply cables. This is due to the fact that current tends to take the path of least resistance. This is called *short-circuiting* of the appliance.

On such occasions, the fuse usually blows off. Otherwise if no fuse was fitted in the circuit, the ‘sparking’ produced by the large current might burn the cable and there are risks of fire being produced.

In a socket for 3-pin plug, the holes for the live and the neutral pins are usually closed by an insulating material called a ‘*blind*’ (Fig. 10.11). This is a safety measure, especially to children who may like to play with the circuit and might cause short circuiting by putting wires in the socket. The ‘blinds’ are opened by the longer earth pin of the 3-pin plug. The moment the earth pin touches and opens the socket, any leakage current through the metal case will straightaway be earthed hence making the appliance safe.

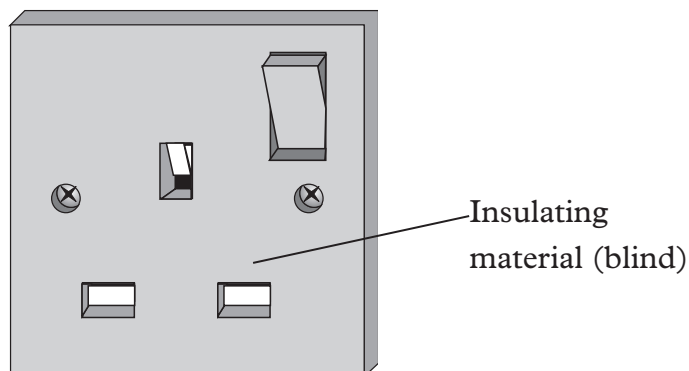


Fig. 10.11: A socket

## 10.4 Household wiring

### Activity 10.6

### To describe domestic wiring system

#### Material:

- Chart showing domestic wiring system

#### Steps

1. Take a walk around the school premises and identify where the following electrical components are situated:
  - (a) Main switch
  - (b) Meter box
  - (c) Sockets
  - (d) Circuit breakers
2. Discuss with your classmate how wiring is done in the school premises.
3. Now look at the chart provided to you. Discuss how domestic wiring is done. How accurate were you before looking at the chart?
4. With the assistance of your teacher, make notes on your findings in your notebook.

Fig. 10.12 shows the drawing for the domestic wiring system consisting of the following: the main fuse, electricity meter, consumer unit or the fuse box, lighting circuit and the ring main circuit.

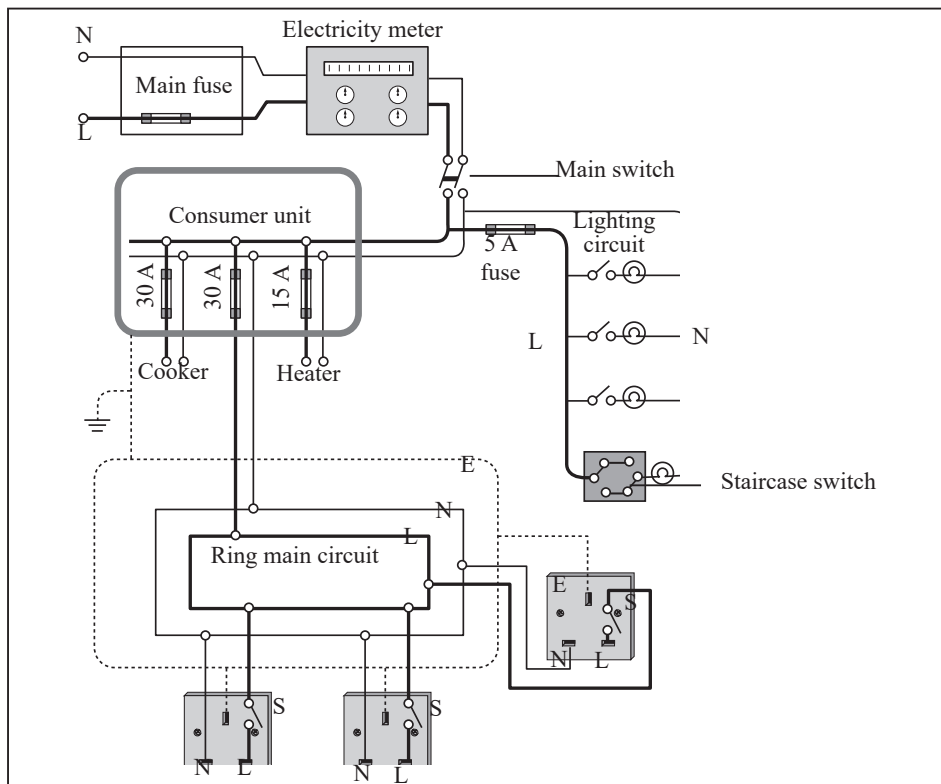


Fig. 10.12: Domestic wiring system

Electricity is supplied from a transformer to the house via two wire ( L and N) cables. Earthing for one of the wires is done at the transformer. It then goes through a fuse which usually differ depending on the amount of the current required. It is then wired to the meter box which contains all the fuses and circuit breakers.

The circuit breakers are normally labelled clearly to show to which each circuit breaker belongs. Wiring for each part of the house is done starting at this unit box also referred to as **consumer unit**.

*Every circuit is connected in parallel with the power supply*, i.e. across the live and the neutral wires. Every circuit receives 240 V ac. There is no connection between the live and the neutral wires except through an electrical appliance.

The *electricity meter* records the electric energy consumed in the whole house.

The *consumer unit* is a junction box which distributes current to several separate circuits. The consumer unit also houses the main switch which can switch off all the circuits in the house, if required.

The *lighting circuit* contains lights for different places and the 2-way switches for places like the staircases. Each lamp is connected in parallel at a suitable point along the cable. The lighting circuit does not require the earth connection, as the current is normally quite low.

The *ring main circuit* provides parallel circuit connections to each electrical appliance plugged into the sockets. Since the current drawn is high, the ring main circuit incorporates the earth wire connection.

### Activity 10.7

#### Replacing a single flash socket with a double socket

##### Materials

- A test light
- Wire strippers
- Wire cutters
- Double outlet sockets
- Screw drivers

##### Procedure

1. Switch off the power at the fuse box. Test the circuit with the test light to ensure that there is no current flowing.
2. Unscrew the fuse plate and disconnect the cables from the terminals of the single socket. Using the wire cutters cut off the extensions of the wires you have unscrewed.
3. Using the wire strippers, strip off the wire casing and prepare the wires.
4. After preparing the wires of the junction box, screw the black wire to the socket terminal with a neutral sign, the red wire to the terminal with live sign, the green wire to the terminal with earthing sign.
5. Fit the new double socket on the wall and use the test light to conform its correctly wired.

## Installation of lightning arrester

### Activity 10.8

To discuss the importance of lightning arrester and how to install it.

#### Material

- A house or picture of a house fitted with a lightning arrester
- Reference books or Internet

#### Steps

1. Identify any house in your school compound or the neighbourhood with a lightning arrester.
2. Take your group members to the house and observe how the lightning protection system has been fitted. Discuss how it works.
3. On going back to class, confirm the facts by conducting a research from the Internet or reference book.
4. Give a summarised report of your findings to the whole class through the secretary.

A lightning protection system performs a simple task. It provides a specific path through which lightning can travel, see Fig 10. 13.

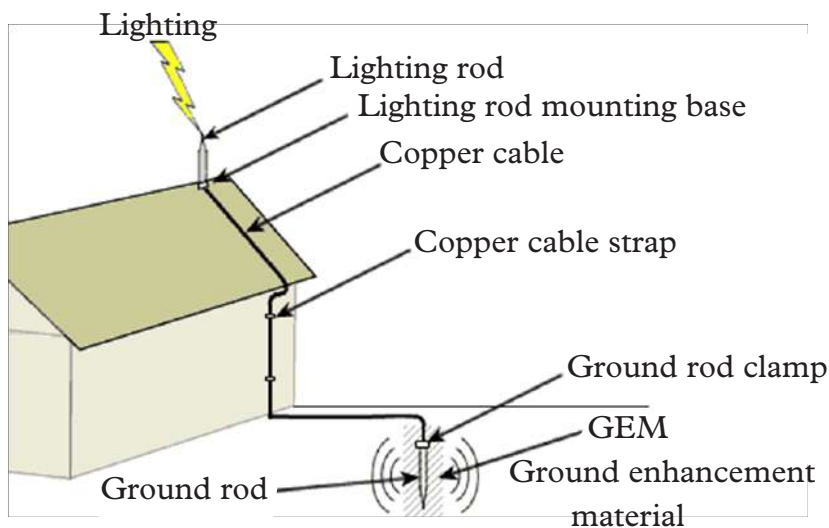


Fig. 10. 13: Lightning arrester



When a house is fitted with a lightning arrester, the destructive power of a lightning strike is directed safely to ground leaving the home, family members and property unharmed.

Copper and aluminium cables are the most appropriate for use as the lightning rods (Fig.10.13). Copper is the material of choice in the conductor cable since it is a better conductor of electricity. Copper wire offers a higher fusing current to discharge lightning and fault current into the ground.



**Note:** Electric grounding cable should not be used.

A lightning protection system should include the following primary components which work together to prevent lightning damage.

1. Lightning rods (Air terminals)
2. Braided conductors (cables)
3. Bonds or metallic bodies
4. Ground rods or ground plates
5. Surge arrester

The arrester is the first line of defence against harmful electrical surges that can enter a structure through power lines. On the other hand, lightning rods protect the structure from a direct lightning strike.

To ensure the highest level of protection of buildings, the following general design rule should be followed:

1. Lightning protection system shall be applied to metal covered buildings in like manner as on building without metal coverings.
2. All buildings must have two groundings as widely separated as possible, preferably at diagonally opposite corners if perimeter distance around the buildings at ground level is 250 feet or less (1 ft = 2.54 cm).
3. Cables should be free of sharp turns. They should remain horizontal or in a downward path towards the ground.
4. If building perimeter is between 250 and 350 feet, then three groundings are required. If it is between 350 feet and 450 feet, then four groundings are required etc.

### Caution

- Copper equipment should not be used on aluminium roofs, aluminium siding or other aluminium surfaces including bare galvanised steel.
- Aluminium equipment should not be used underground.
- Aluminium equipment should not be used on copper roofing or other copper surface.
- Copper and aluminium conductor should not be interconnected except with acceptable bimetallic connectors.

## 10.5 Dangers of electricity

### Activity 10.9

To describe the dangers of electricity and safety measures

#### Materials

- Reference books
- Internet enabled computer

#### Steps

1. Discuss the possible electrical hazards in our home and safety measures needed to be taken.
2. Confirm your faults in step 1 above by conducting a research from the internet or reference books on the dangers of electricity.
3. Present a brief report on your findings to the whole class through your group secretary.

Working with electricity can be dangerous. Engineers, electricians and other workers deal with electricity directly including on overhead lines, electrical installation and circuit assembling. Users like office workers, farmers and construction workers deal with electricity indirectly.

Some of us may have experienced some form of shock where electricity causes our body to experience pain or trauma.

Those of us who were fortunate, the extend of that experience was limited to tingles or jolts of pain. But electrical shocks from electrical circuits are capable of delivering high power to loads, which cause much more serious damage.

It is therefore important to be aware of hazards brought about by electricity and how to avoid them in order to be safe.

## Electrical hazards

A hazard is a situation that poses a threat to life, health, property or environment. The following are some common electrical hazards in our homes, offices and factories.

- Poor wiring and defective electric wires can lead to electric shock and fires.
- Water outlets being close to electric outlets.
- Pouring water on electrical fire. This can lead to electric shock.
- Covering electrical cords and wires with heavy cover can lead to overheating.
- Overloading the outlets leading to overheating and electrical fire.
- Use of long extension cords which can cause tripping or accident.
- Touching electrical appliances with wet hands leading to shocks.
- Broken sockets and electrical appliances leading to electric shock.

## 10.6 Electrical safety

Every electricity user should observe safety measures when using electricity and electrical appliances. The following are some of the electrical safety measures.

- Do not touch naked electric cables with bare hands to avoid electric shock.
- Always pay attention to the warning signals given out by your appliances e.g. if a circuit breaker repeatedly trips, you should confirm the problem.

### Be safe

Whenever you see this electricity sign it warns you to keep off. You may be electrocuted.



- Use the right size circuit breakers and fuses to avoid overloading.
- Ensure that potentially dangerous electrical devices or naked wires are out of reach of children.
- You should avoid cube taps and other outlet-stretching devices.
- Always replace broken plugs and naked wires.
- Use the correct appliances in a socket to avoid overload.

### Exercise 10.2

1. State the international standard colours for the live (line), neutral and earth leads of a 3-core flex.
2. Define 'fuse' and state its function in an electrical circuit.
3. Sketch and label a three pin plug.
4. Explain why the earth connection is important.
5. (a) Explain how to install lightning arrestor in a house.  
(b) Highlight the general design rule that must be followed to ensure highest level of electrical safety of modern houses.
6. A laboratory building in a of Voluntary Counselling and Testing Centre (VCT) is to be supplied with electricity. Briefly explain how wiring would be done in the laboratory building for effective supply of electricity.

### Unit summary and new words

- An electronic symbol is a pictogram used to represent various electrical and electronic devices in a schematic diagram of an electrical or electronic circuit.
- A fuse is a short thin wire of low melting point. It melts when a large current flows through it hence breaking the circuit.
- The earth wire is connected to the ground and prevent an appliance or house from becoming live. This is important in case there is an electrical fault.
- Electric Lamps are of many types. They are categorised into three major groups namely: Incandescent, LED and gas-discharge lamps.
- A circuit breaker cuts off the flow of current when there is an electric fault within the circuit thus keeping the premises and appliances safe from electric fire.
- When wiring a house, there are many types of wire to choose from, some copper, others aluminium, some rated for outdoors, others indoors.
- Every electricity user should be aware of electrical hazards and practice safety measures.

## Unit Test 10

1. (a) Name five electrical components used in house wiring.  
 (b) Draw the standard electrical symbols used for each of the component named in (a)  
 (c) Briefly explain the functions of each of the component you named in (a) above.
2. Explain why the earth connection is so important to appliance at home.
3. Fig.10.14 shows an electrical cable. Name the earth, live and neutral wire.



*Fig. 10.14: Electrical cable*

4. (a) Name three types of electric lamps.  
 (b) List any two gases used in lamps.  
 (c) What is the purpose of the presence of the gases inside the bulb?
5. Brief explain the function of the following electrical component in an electric circuit  
 (a) a circuit breaker  
 (b) a fuse
6. Describe briefly how you can do electrical wiring in a house.
7. Mukantagara a student in Senior 3 saw an electric post with cables collapse and block the path way. Describe some of the safety measures she and the people near the cable should observe for them to be safe from any harm.
8. Explain why a fuse is always fitted to the live wire.
9. State three necessary precautions to be taken when connecting a metal-framed electrical appliance to the mains power supply?
10. An electric iron rated 240 V, 750 W is to be connected to a 240 V mains supply through a 3 A fuse. Determine whether the fuse is suitable or not.
11. Find the maximum number of 75 W bulbs that can be connected to a 3A fuse on a mains power supply of 240 V.
12. In the circuit shown in Figure 10.15, each bulb is rated 6 V, 3 W.

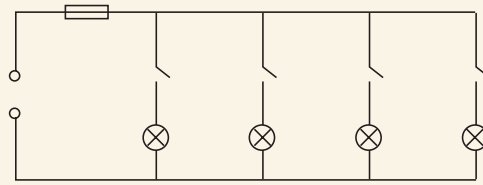


Fig. 10.15

- (a) Calculate the current through each bulb when the bulbs are working normally.
  - (b) Is a 3 A fuse suitable for the circuit when all the switches are closed?
  - (c) Calculate the power delivered by the power supply
  - (d) What is the advantage of connecting all the bulbs in parallel rather than in series?
13. Figure 10.16 shows a staircase double switch.

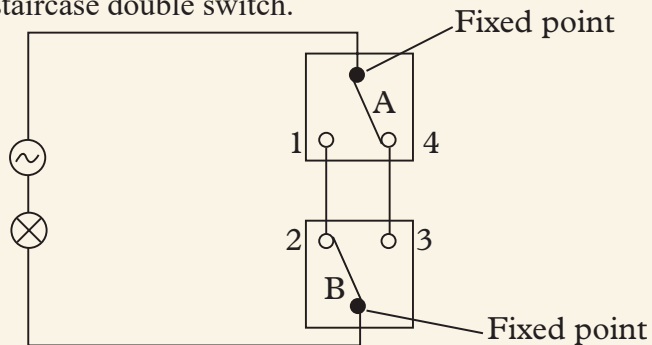


Fig. 10.16

In Table 10.4, write down whether the lamp will be ON or OFF for the various combinations of switch positions.

Table 10.4

Position of switch A	Position of switch B	Lamp ON/OFF
1	3	
1	2	
4	3	
4	2	

## UNIT

## 11

## Basic alternating current circuits

**Key Unit Competence**

By the end of the unit, the learner should be able to design and analyse simple alternating current circuits.

**Learning objectives****Knowledge and understanding**

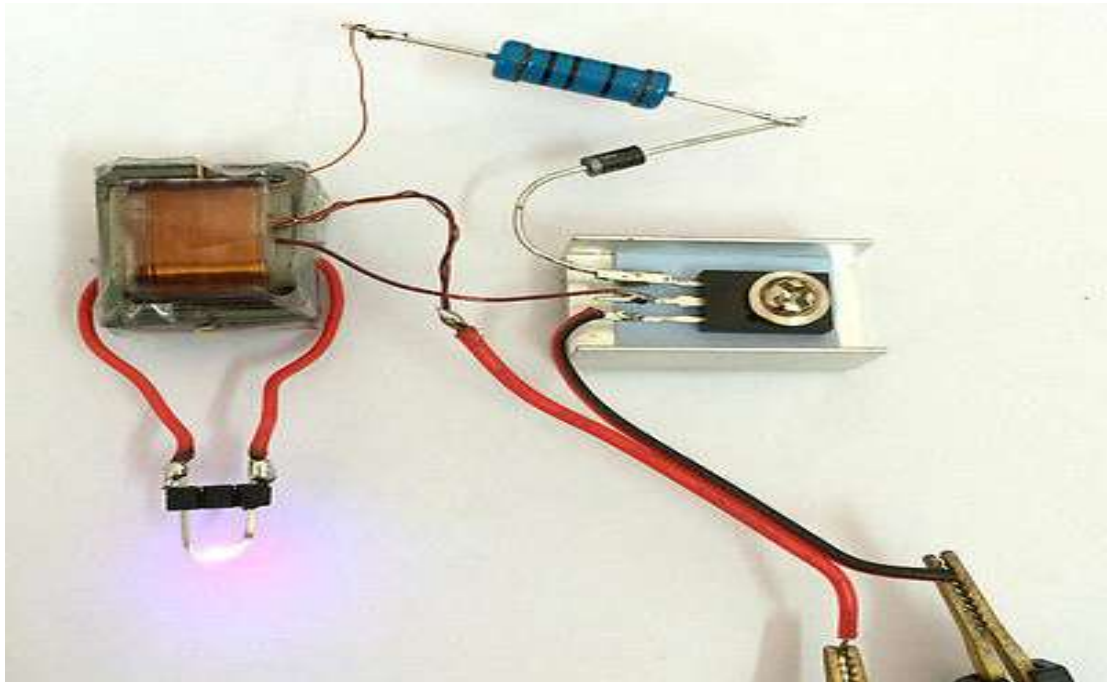
- Identify circuit symbols representing electrical components.
- Describe design of electrical circuits using different electrical components.
- Design an electric circuit consisting of AC voltage and inductor, resistor and capacitor.
- Describe the function of inductor in an electric circuit.

**Skills**

- Identify and apply electrical components in AC circuits
- Differentiate between an alternating current and a direct current.
- Explain function of inductor, resistor and capacitor in electric circuits.
- Manipulate apparatus and equipment, given procedures, to obtain data.
- Evaluate and draw conclusion using experimental results.

**Attitude and value**

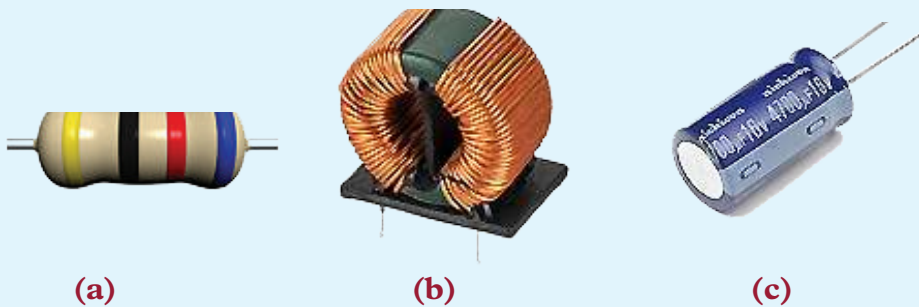
- Appreciate applications of electric circuits.
- Be aware of the safety precaution to be observed while handling electrical circuits.
- Appreciate advantage of a.c. over d.c.



## Introduction

### Unit Focus Activity

Fig. 11.1 shows three different electronic components



*Fig. 11.1: Pictures of electronic components*

1. Identify each component.
2. Describe the function of each component in a circuit.
3. Sketch a symbol circuit diagram showing the three components connected in series with an a.c supply.
4. Sketch the graph of the voltage signal output from the circuit in step 3 above.

In unit 7, we discussed and defined what alternative current (a.c) is. In this unit, we are going to design and analyse simple alternating circuits.



## 11.1 Standard symbols used in electric circuit and function

### Activity 11.1

#### To draw circuits symbols for electronic components

#### Materials

- Cell
- Bulb
- Capacitor
- Connecting wires
- Resistors
- A.C source
- Inductor
- Switch
- D.C source


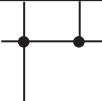
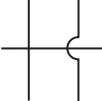


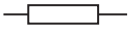
#### Steps

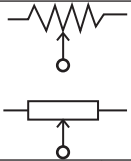
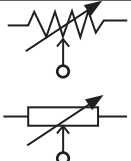
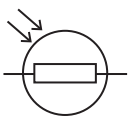
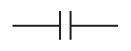
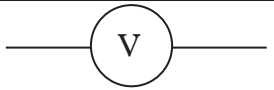
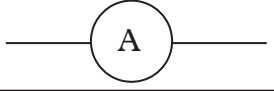



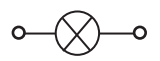

1. Your teacher will provide you with the above circuit components.
2. Briefly describe the function of each in a circuit. Summarise your report in a table.
3. Suggest three precautions that one should observe when designing and connecting circuits.
4. Compare your findings with those of other groups.

We have already learnt some common electrical symbols used in d.c circuit. Let us now consider some components used in simple a.c circuits namely inductor, resistor, a.c power source, capacitor, wires.

The table 11.1 summarizes these symbols and their function.

Table 11.1: Summary of electrical components, symbol and function.

Circuit symbol	Component name	Function
	Electrical wire	Used to connect one component to another.
	Connected wires	To show connected crossing
	Not connected wires	To show wires are not connected
	Switch	Disconnects current when open
	Earth ground	Used for zero potential and electrical shock protection
	Resistor (R)	Used to restrict the amount of current flow through a device.

	Potentiometer	Adjustable resistor has 3 terminals – used to divide electric potential
	Variable resistor/ rheostat	Adjustable resistor has 2 terminals – used to set the resistance
	Photoresistor/light dependent resistor LDR	Used to measure resistance that changes with the change in light intensity
	Capacitor (C)	It acts as short circuit with a.c and open with d.c
	Voltmeter	Used to measure the voltage.
	Ammeter	Used to measure the current.
	Galvanometer	Used to measure very small current.
	Inductor (L)	Coil/solenoid that generates magnetic field
	Variable inductor	Used in the tuned circuit of radio transmitter
	Indicator Lamp	Indicates current flow by lighting.
	a.c supply	Supplies alternating voltage.

## 11.2 Differences between alternating current (a.c) and direct current (d.c)

### Activity 11.2

To differentiate between d.c and a.c sources

#### Materials

- Dry cells
- Bicycle dynamo
- Galvanometer

**Steps**

1. Connect a dry cell across a centre-zero milliammeter and a resistor, making sure the positive polarity is connected to the positive polarity of the milliammeter. Note and explain what happens to the pointer.
2. Connect a bicycle dynamo in series with a centre-zero galvanometer and resistor. Make the dynamo turn by use of the wheel. Observe and explain what happens to the galvanometer pointer.
3. Compare and discuss your observation in steps 1 and 2 with your classmates.

Fig. 11.2 shows an electric circuit of d.c and a.c sources respectively.

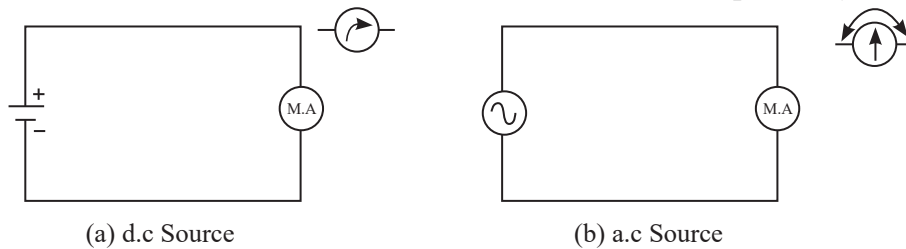


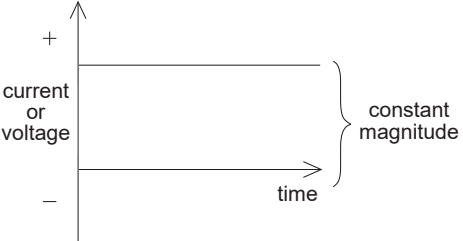
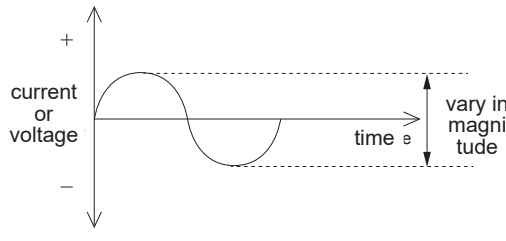
Fig. 11.2: The d.c and a.c source

The polarity for d.c source remains constant making the current to flow in only one direction while that of a.c source switches polarity from positive to negative and back again over time. This makes the current with respect to the voltage oscillates back and forth.

The oscillating shape of a.c supply follows that of mathematical form of a sine wave. For d.c, voltage is the same as that across the resistor.  $V_{dc} = V_R$ . For the a.c, the  $V_{ac} = V_{peak} \sin \omega t$ .

When working with a.c voltages and currents, we use the r.m.s. values which is the equivalent steady d.c (constant) value which gives the same effects. For example, a lamp connected to a 6 V r.m.s a.c supply will shine with the same brightness when connected to a steady supply by d.c supply. Table 11.2 summarises the main differences between ac and dc.

**Table 11.2 difference between d.c and a.c power source**

	<b>d.c</b>	<b>a.c</b>
1.	Flows in one direction in the circuit and has of constant magnitude 	Reverses its direction periodically while continuously varies in magnitude. 

2.	d.c voltage cannot travel very long distance due to energy losses.	Easier, safe and cheaper to transfer over long distances.
3.	Frequency = 0 Hz	Frequency = 50 Hz or 60 Hz depending on the country.
4.	Obtained from a cell or battery	Obtained from a.c generator and the mains
5.	Hindrance to flow of current in d.c circuit called resistance	Hindrance to flow of current in a.c circuit is called impedance
6.	Power factor is always 1	Power factor lies between 0 and 1
7.	Can be stored in batteries	Cannot be stored.

### 11.3 The circuit for analysing resistors, capacitors and inductors in a.c circuits

In order to compare the behavior of a resistor, inductor and capacitor in an a.c circuit, we need to design a circuit diagram that can be used by the three components. The source of a.c should be such that its voltage supply and frequency can be varied. Hence a low frequency generator is recommended.

#### Activity 11.3

To design a circuit for analysing a.c circuits involving resistors, capacitors and inductors

#### Materials

- Low frequency generator
- d.c voltmeter (centre – zero)
- d.c ammeter (milliammeter and centre – zero)
- Inductor
- Stop watch
- Carbon resistor
- Frodile clips
- Capacitor
- Connecting wires

#### Steps

Connect the circuit as shown in Fig. 11.3

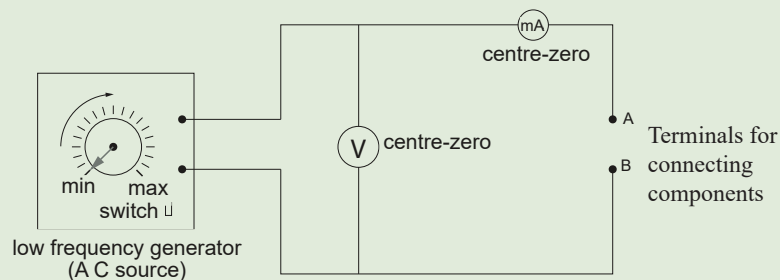


Fig 11.3 circuit diagram to analyse resistors, capacitor and inductors in a.c circuits.

The circuit is now ready for use

## 11.4 A single resistor connected in series to an a.c source.

### 11.4.1 Variation of current and voltage with time

#### Activity 11.4

To analyse the behaviour of a single resistor connected to an a.c source

#### Materials

- A carbon resistor (2 k $\Omega$ )
- Stop watch
- Crocodile clips
- Connecting wires

#### Steps

1. Set the low frequency generator to the minimum value.
2. Connect a carbon resistor between points A and B in the circuit made in Activity 11.3.
3. Connect the low frequency generator to the main (make sure the generator is “off”). Switch on the generator.
4. Set the generator at a frequency where both the milliammeter and voltmeter show a reading. What happens to this reading with time.
5. Record the variation of current and voltage with time Table 11.3.

Table 11.3.

	Time (S)	current (mA)	Voltage (V)	$\frac{V}{I}$	power (VI)
1					
2					
3					
4					
5					

6. Repeat the experiment by increasing the frequency of a.c signal.
7. On the same axes, plot the graph of variation of current and voltage with time.
8. Calculate the ratio of  $\frac{V}{I}$  at various time.
9. Calculate the power in the resistor.
10. Show on the graph the variation of current and voltage with time. Also show how the power varies with time.

When a single pure resistor is connected in series to an a.c source, the current through it and voltage across it each vary sinusoidally with time as shown in Fig. 11.4.

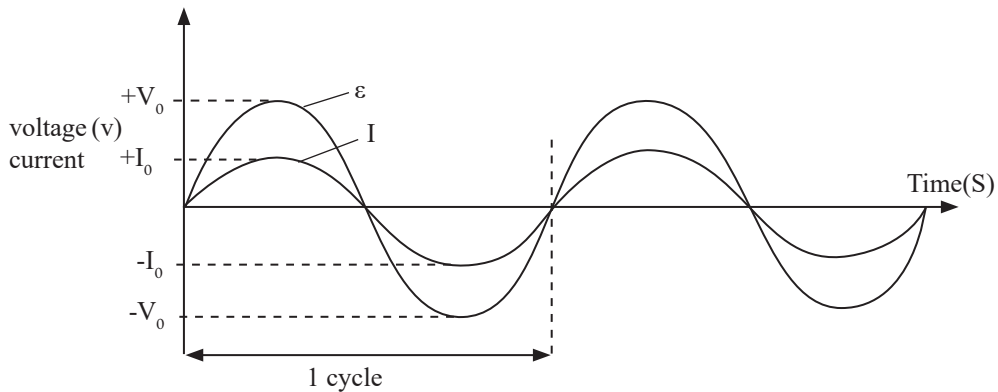


Fig. 11.4: Variation of current and also voltage with time for a resistor in a.c circuit

During  $\frac{1}{2}$  cycle, the current flows in one direction and in the other  $\frac{1}{2}$  cycle the current flows in the opposite direction. The e.m.f and the current reach the maximum and minimum at the same time. When this happens, we say that the current and voltage are **in phase**. In such a case, we say the e.m.f. and the current are directly proportional. This is the same case with a d.c. circuit, except that the values of e.m.f. and current do not change.

Hence, Ohm's law can be used in both d.c and a.c circuit to calculate resistance, voltages, current and power. The ratio of voltage to the current gives the resistance of the resistor to the flow of a.c current. In a.c, this resistive nature is called **impedance (Z)**. The units of impedance are ohms ( $\Omega$ ).

$$\text{Impedance } Z = \frac{V_{(r.m.s)}}{I_{(r.m.s)}}$$

### 11.4.2 Electrical resistance and frequency

#### Activity 11.5

To show the relationship between resistance and frequency

#### Materials

- Ammeter
- Voltmeter
- Bulb
- Connecting wires
- Low frequency generator

#### Steps

1. Connect the circuit shown in Figure 11.5

Low frequency generator

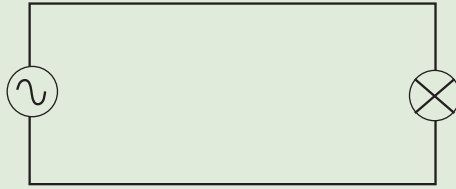


Fig. 11.5 relationship between resistance and the frequency signal

2. Note the brightness of the bulb.
3. Change the frequency of a.c. supply and again note the brightness of bulb. What do you observe on the brightness of the bulb? Explain.

The frequency of the a.c source (at constant voltage) does not affect the brightness of the bulb. Since the brightness is a measure of the resistance, we can conclude that the frequency of an a.c source does not affect the resistance (impedance of the circuit). This can be shown by the graph Fig. 11.6

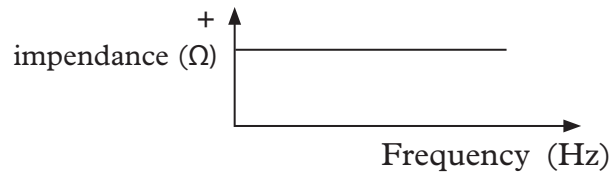


Fig. 11.6: A graph of resistance against frequency

### 11.4.3 Power in a.c circuit

The voltage and current reach their maximum and minimum value at the same time.

Fig. 11.7 shows the variation of current, voltage, power with time plotted on the same axes.

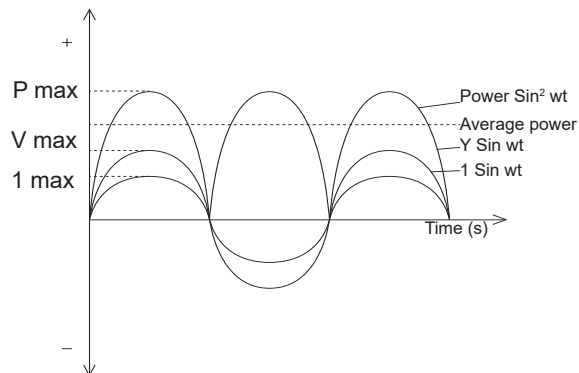


Fig. 11.7 Variation of current, voltage and power with time

The power dissipated in a pure resistor connected to a.c supply is given a

$$P = V_{(r.ms)} \times I_{r.ms} = I_{r.ms}^2 \times R = \frac{V_{r.ms}^2}{R}$$

### Example 11.1

A 1000 W heater is connected to a 250 V a.c. supply voltage. Calculate:

- the current taken from the mains,
- the impedance (a.c resistance) of the heater when it is hot.

**Solution**

$$I = \frac{P}{V} = \frac{1000 \text{ W}}{250 \text{ V}} = 4 \text{ A}$$

$$Z = \frac{V}{I} = \frac{250}{4} = 62.5 \Omega$$

### Example 11.2

Find the power being consumed by a 100  $\Omega$  resistive element connected a 240 V a.c supply.

**Solution**

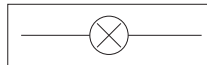
$V_{\text{resistor}} = V_{\text{supply}}$  (only one component is connected)

$$I = \frac{V_R}{R} = \frac{240}{100} = 2.4 \text{ A}$$

$$P = I^2 R = 2.4^2 \times 100 = 576 \text{ W}$$

### Exercise 11.1

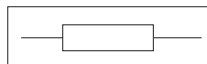
- Differentiate between resistance (R) and Impedance (Z)
- Match the following symbols with their component.



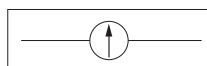
pure resistor



centre-zero galvanometer



wire



bulb



A C power supply



3. Using the standard symbols, draw a simple circuit showing a resistor, bulb, connected to A.C power supply.
4. The variation of current (I), voltage (v) and power (P) through a resistor connected to a low frequency generator.

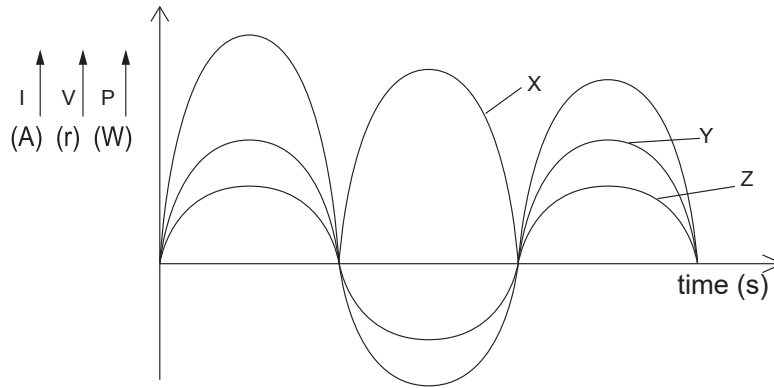
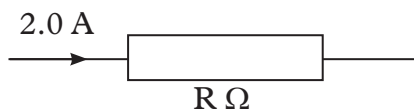


Fig. 11.8

Identify which curve represents:

- (a) Current                      (b) Voltage                      (c) Power

5. The current through a resistor in an a. c circuit is given by  $I = I_0 \sin \omega t$ .
  - (a) Explain the various symbols and terms in this expression.
  - (b) Sketch a graph representing this expression.
  - (c) Write down the expression for instantaneous voltage across the resistor.
6. A direct current of 2.0A passes through a resistor of value  $R \Omega$ . Calculate the peak value of an a.c which produces three times the heat per second as the 2.0A:



7. A low frequency a.c source gives a signal output of 4V peak value when connected to a  $100 \Omega$  resistor R.
  - (a) Draw a phasor diagram for this connection.
  - (b) Calculate the current through R in milliamperes.
8. The Fig 11.9 shows a resistor R connected to a signal generator while Fig.11.10 shows how the voltage (V) varies with time.

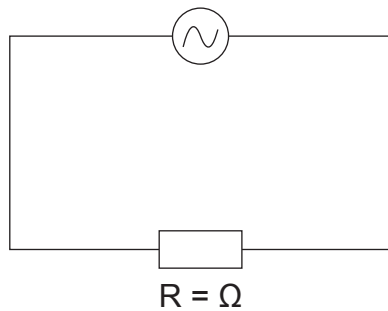


Fig. 11.9

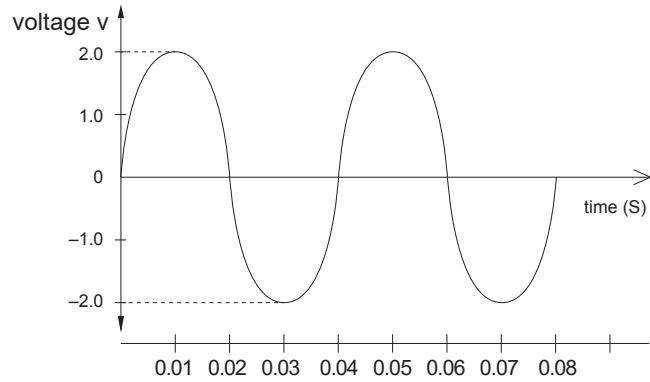


Fig. 11.10

- Find the frequency of the signal.
- Calculate the value  $V_{\text{r.m.s}}$ .
- Sketch the variation of current in  $R$  with time  $t$  for the same time interval.
- Use one or both of the graph to determine the power dissipated in  $R$  when  $t = 0.0150$ .

## 11.5 A single capacitor connected in series to an a.c source

### Activity 11.6

To describe inductor connected in series with a.c supply source

#### Materials.

- Capacitor
- Crocodile clips
- Millimeter
- Connecting wires
- Voltmeter
- A.C. power supply

#### Procedure

- Repeat activity 11.3 but use a capacitor across A and B as shown in Fig 11.11

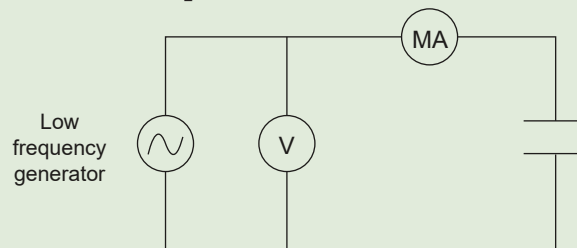


Fig. 11.11

When the capacitor is connected directly across an a.c supply, it will alternately charge and discharge at a rate determined by the frequency of the supply. The capacitance in a.c circuits varies with frequency, as the capacitor is being alternately

charged and discharged. The bulb in the circuit will light due to the charging and discharging current that passes through it.

The charging current is directly proportional to the rate of change of the voltage across the plates, with the rate of charge at its greatest as the supply voltage crosses over from its positive half cycle to its negative half cycle or vice versa at points  $0^\circ$  and  $180^\circ$  along the sine wave.

Consequently, the least voltage change occurs when the a.c sine wave crosses over at its maximum or minimum peak voltage level. At these positions in the cycle, the maximum or minimum currents are flowing through the capacitor circuit. See Fig. 11.12.

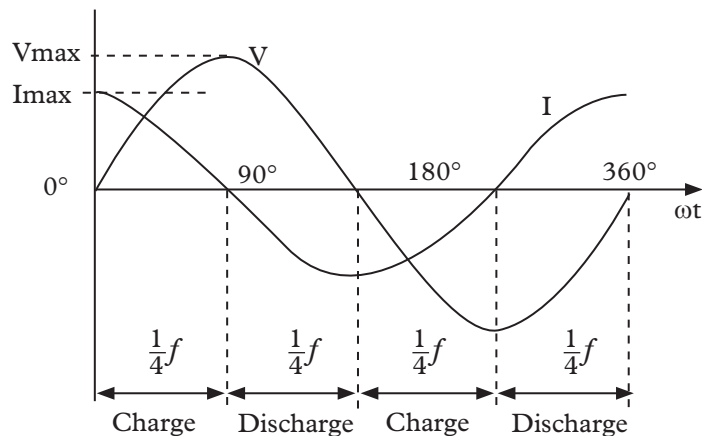


Fig. 11.12: A graph showing charging and discharging at a capacitor in a.c circuit

At  $0^\circ$ , the rate of change of the supply voltage is increasing in the positive direction resulting in a peak value at  $90^\circ$ . For a very brief instant in time, the supply voltage is neither increasing nor decreasing so there is no current flowing through the circuit.

As the applied voltage begins to decrease to zero at  $180^\circ$ , the slope of the voltage is negative so the capacitor discharges in the negative direction. The bulb's lighting increases slowly. At the  $180^\circ$  point, the rate of change of the voltage is at its maximum again so maximum current flows at that instant and so on.

We can therefore say that for capacitors in an a.c circuits, **the instantaneous current is at its minimum or zero whenever the applied voltage is at its maximum and likewise the instantaneous value of the current is at its maximum or peak value when the applied voltage is at its minimum or zero.**

From the waveform above, we can see that the current is leading the voltage by  $\frac{1}{4}$  cycle.

Like resistors, capacitors also offer some form of resistance against the flow of current through the circuit. The resistance to the flow of a.c current by a capacitor is known as **reactance**  $x_c$  or **capacitive reactance**, its SI unit is ohms ( $\Omega$ ). Capacitive Reactance in an a.c is given by:  $X_c = \frac{V_{r.m.s}}{I_{r.m.s}}$  (ohms).

In a graph of  $V_{r.m.s}$  against  $I_{r.m.s}$  (Fig. 11.13) the slope gives the reactance.

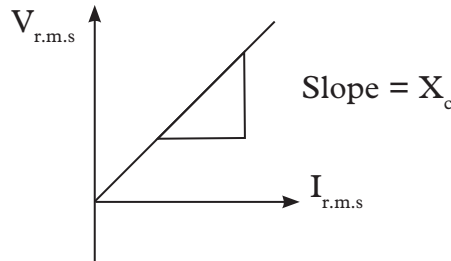


Fig. 11.13: Graph of  $V_{r.m.s}$  against  $I_{r.m.s}$  for capacitor.

### Capacitive reactance, current, capacitance and frequency

The capacitive reactance of the capacitor decreases as the frequency across it increases. Therefore, capacitance is inversely proportional to frequency, that is

$$X_c \propto \frac{1}{f}$$

The graphs in Fig. 11.14(a), (b) and (c) show the variation of capacitive reactance, against current, frequency of a.c source and capacitance.

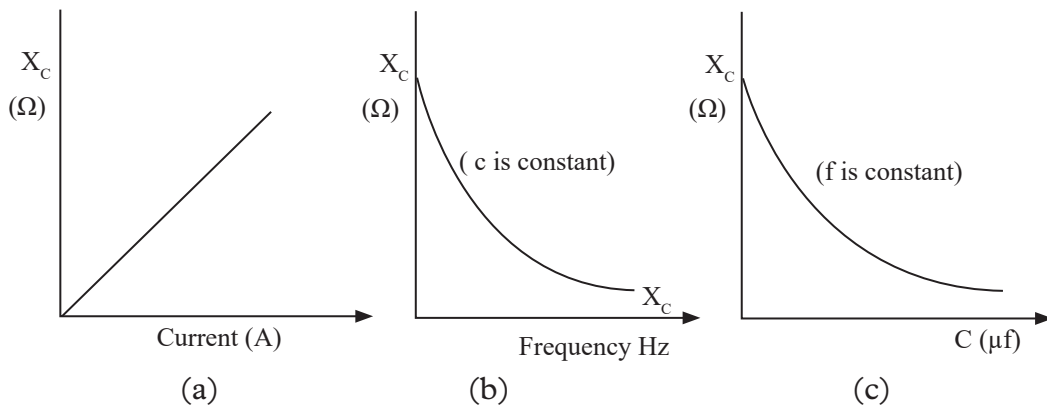


Fig. 11.14: A graph of capacitive reactance against current and frequency and capacitance.

It has been shown that.

$$X_c = \frac{1}{2\pi f C} \Rightarrow X_c = \frac{1}{C\omega} \quad (\text{since } 2\pi f = \omega)$$

Where,  $f$  is in Hertz (Hz) and  $C$  is in Farads (F), and angular frequency  $\omega$  is in radians per second.

Looking at the graph in Fig. 11.14 (b), we see that as the frequency increases,

the current flowing through the capacitor increases in value because the rate of voltage change across its plates increases. At very high frequencies, a capacitor has zero reactance (short-circuit).

From the graph in fig. 11.14(c), we see that for a d.c supply, a capacitor has infinite reactance (open-circuit).

Fig. 11.15 shows the variation of power in a capacitor in a.c circuit.

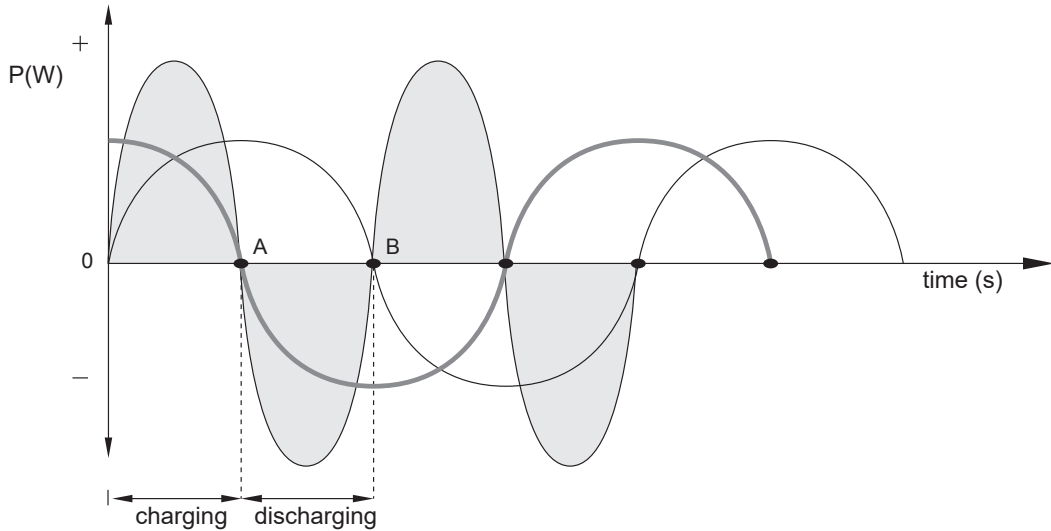


Fig. 11.15: Variation of power in a capacitor in a.c.

In the first  $\frac{1}{4}$  cycle, OA, power is drawn from the source and energy is stored in the capacitor. In the second quarter cycle AB, the energy is being returned back to the source. The mean power is therefore zero over a cycle.

### Example 11.3

When a parallel plate capacitor was connected to a 60 Hz a.c supply, it was found to have a reactance of 390 ohms. Calculate the value of the capacitance in microfarads.

$$X_C = \frac{1}{2\pi fC} \Rightarrow C = \frac{1}{2\pi fX_C}$$

$$C = \frac{1}{2\pi \times 60 \times 390} = 6.8 \mu\text{F}$$

### Example 11.4

- (a) Draw a circuit with 100 nF connected to  $2V_{\text{r.m.s}}$  a.c source of 1 kHz supply.
- (b) Calculate the:
- $X_C$
  - $I_{\text{r.m.s}}$  (Give your answer in appropriate form)

**Solution**

(a) The circuit is as shown in Fig. 11.16

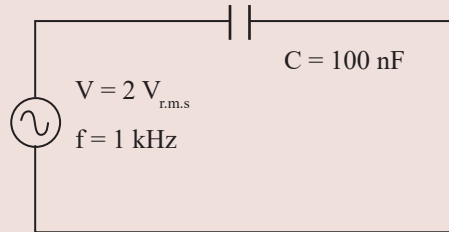


Fig. 11.16: Electric circuit

$$(b) (i) X_C = \frac{1}{2\pi fC} = \frac{1}{2\pi \times 1 \times 10^3 \times 100 \times 10^{-9}} = 1591.5 \Omega$$

$$(ii) I_{r.m.s} = \frac{V_{r.m.s}}{X_C} = \frac{0.707 \times 2V}{1591.5 \Omega} = 4.44 \times 10^{-4} A$$

To give your answer in appropriate form, use mA,  $\mu$ A etc e.g.

$$I_{r.m.s} = 444 \mu A$$

**Exercise 11.2**

For questions 1 - 9. Select the most appropriate answer for the choices given.

- As the size of the plates in a capacitor increases, all other factors being constant,
  - The value of  $X_C$  increases negatively
  - The value of  $X_C$  decreases negatively.
  - The value of  $X_C$  does not change.
  - We cannot say what happens to  $X_C$  without more data.
- If the dielectric material between the plates of a capacitor is changed, all other things being equal,
  - The value of  $X_C$  increases negatively.
  - The value of  $X_C$  decreases negatively
  - The value of  $X_C$  does not change.
  - We cannot say what happens to  $X_C$  without more data.
- As the frequency of a wave gets lower, all other things being equal, the value of  $X_C$  for capacitor
 

A. Increases negatively.	B. Decreases negatively.
C. Does not change.	D. Depends on the current.

4. What is the reactance of a 330-pF capacitor at 800 kHz?
 

A. $-1.66 \Omega$	B. $-0.00166 \Omega$
C. $-603 \Omega$	D. $-603 \text{ k}\Omega$
5. A capacitor has a reactance of  $-4.50 \Omega$  at 377 Hz. What is its capacitance?
 

A. $9.39 \mu\text{F}$	B. $93.9 \mu\text{F}$
C. $7.42 \mu\text{F}$	D. $74.2 \mu\text{F}$
6. A  $47\text{-}\mu\text{F}$  capacitor has a reactance of  $-47 \Omega$ . What is the frequency?
 

A. 72 Hz	B. 7.2 MHz
C. $0.000072 \text{ Hz}$	D. 7.2 Hz
7. A capacitor has  $X_C = -8800 \Omega$  at  $f = 830 \text{ kHz}$ . What is C?
 

A. $2.18 \mu\text{F}$	B. 21.8 pF
C. $0.00218 \mu\text{F}$	D. 2.18 pF
8. A capacitor has  $C = 166 \text{ pF}$  at  $f = 400 \text{ kHz}$ . What is  $X_C$ ?
 

A. $-2.4 \text{ k}\Omega$	B. $-2.4 \Omega$
C. $-2.4 \times 10^{-6} \Omega$	D. $-2.4 \text{ M}\Omega$
9. A capacitor has  $C = 4700 \mu\text{F}$  and  $X_C = -33 \Omega$ . What is f?
 

A. 1 Hz	B. 10 Hz
C. 1 kHz	D. 10 kHz
10. Briefly describe what happens when a capacitor is connected to an a.c source.
11. A sinusoidal p.d of r.m.s value of 10V is applied across a  $20\mu\text{F}$  capacitor.
  - (a) What is the peak capacitance of the capacitor.
  - (b) Draw a graph of current on capacitor with time.
  - (c) 50Hz Calculate the r.ms. current through the capacitor.
12. (a) What do you understand by the term reactance.
  - (i) Describe an experiment to investigate the dependence on frequency of the reactance of a capacitor.
  - (ii) Sketch a graph to illustrate this dependence.

### 11.6 A single inductor connected in series to an a.c source

An inductor is basically a coil or loop of wire that is either wound around a hollow tube former or wound around a ferromagnetic material.

### 11.6.1 Variation of voltage and current through an inductor in a.c circuit

#### Activity 11.7

To analyse the behaviour of a single inductor in an a.c circuit

#### Materials

- Inductor
- Crocodile clips
- Voltmeter
- Connecting wires
- Low a.c frequency generator
- Ammeter

#### Produce

- Repeat activity 11.6 but use an inductor across A and B instead of capacitor as shown in Fig. 11.17

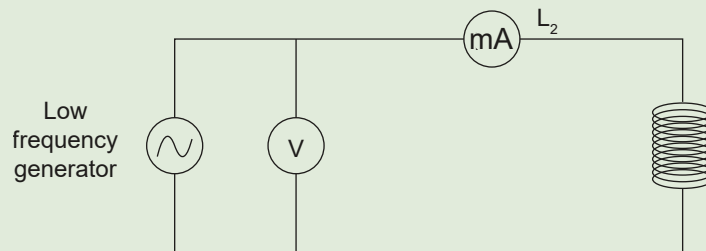


Fig. 11.17

When a single inductor is connected in series with an a.c source, the voltage ( $V_L$ ) and current ( $I_L$ ) through the inductor vary with time as shown in Fig. 11.18.

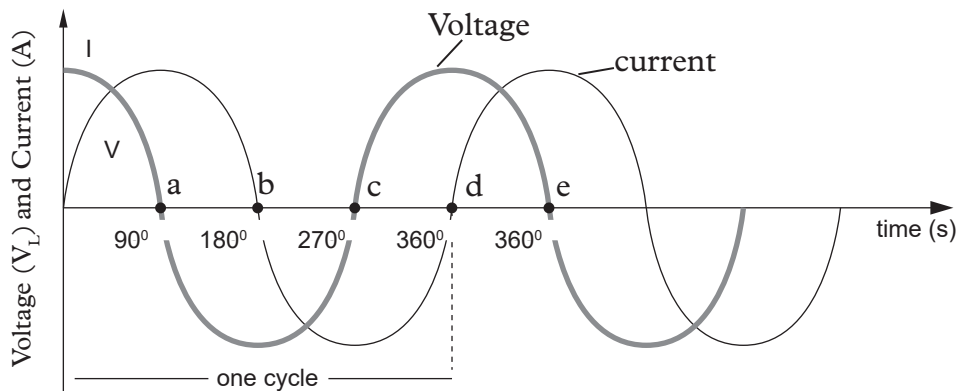


Fig. 11.18: Variation of voltage and current with time for an inductor.

From the graph, we see that when the voltage become negative just after point *a*, the current starts to decrease and become zero at point *b*. The current then becomes negative, following the voltage. The voltage becomes positive at point *c* where it begins to make the current less negative. At point *d* the current becomes zero again just as the voltage reaches its positive peak value to start another cycle. Hence, when a sinusoidal voltage is applied to an inductor, the voltage leads the



current by  $\frac{1}{4}$  of a cycle or by a  $90^\circ$  phase angle as shown. In other words the current lags behind voltage.

When an inductor is connected across an a.c supply, the sinusoidal voltage will cause a current to flow and rise from zero to its peak value. This rise or change in the current induces a magnetic field within the coil which in turn will oppose or resists this change in current in accordance with lenzs law. Hence, like a capacitor, an inductor offers opposition to the flow of a.c.

This opposition to the flow of current in inductor called **inductive reactance  $X_L$** . The unit symbol for inductive resistance ( $X_L$ ) is ohms ( $\Omega$ )

Like in a resistor, the effective opposition to the flow of current in the inductor to a.c in given by a version of ohms law Fig. 11.19.

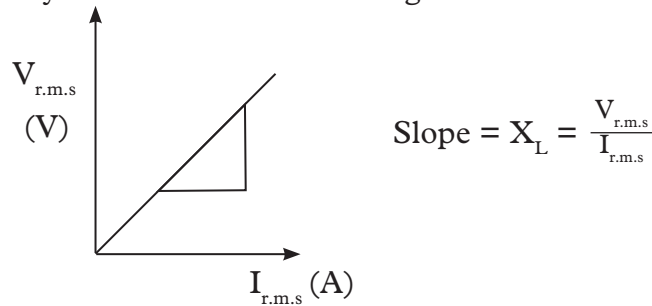


Fig. 11.19

### 11.6.2 Variation of inductive reactance $X_L$ , with frequency and inductor

#### Activity 11.8

To investigate relationship between inductive reactance and frequency.

- Repeat activity 11.3 but change the frequency of the low frequency generator, keeping the inductance  $L$  constant.
- Repeat activity 11.3 but change the inductance  $L$  keeping frequency constant.
- Describe the relationship between  $X_L$  and  $f$ ,  $X_L$  and  $L$ .

Fig. 11.20 and 11.21 shows variation of inductive reactance with inductance and frequency respectively.

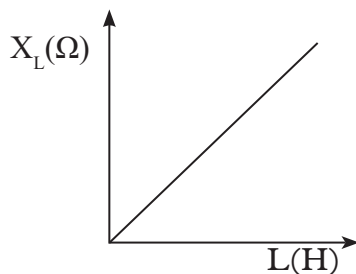


Fig. 11.20: Variation of  $X_L$  with  $L$

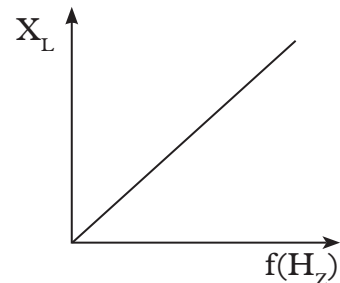


Fig. 11.21: Variation of  $X_L$  with  $f$

From the graphs, we observe that increasing frequency ( $f$ ) and inductance ( $L$ ) increase inductive reactance  $X_L$ .

$$X_L \propto fL \Rightarrow \boxed{X_L = 2\pi fL}$$

$$\text{Since } 2\pi f = \omega \text{ then } \boxed{X_L = \omega L}$$

Where  $\omega$  is angular frequency in radians per second.

### 11.6.3 Variation of power with time in an inductor

Since  $P = VI$ , the variation of  $V$  and  $I$  shows give how the power in and an inductor varies (Fig.11.22).

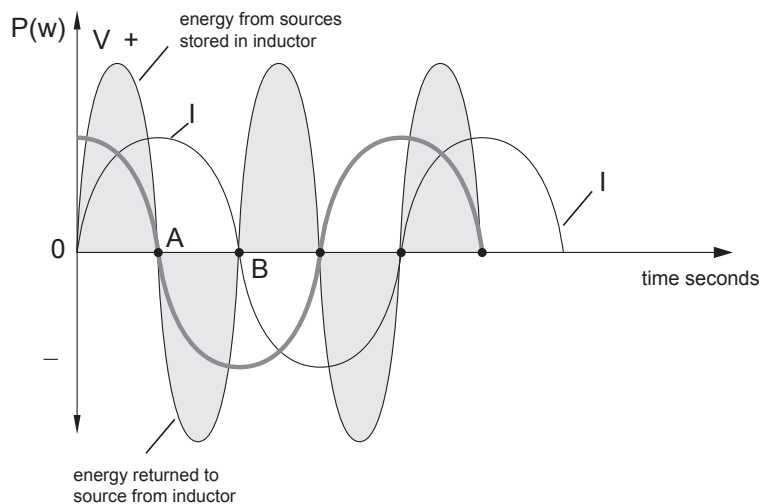


Fig. 11.22: Variation of power with time in an inductor.

In the first  $\frac{1}{4}$  of cycle OA, power is drawn from the source and energy is stored in the magnetic field of the inductor. In the second quarter cycle OB, the current and magnetic field decrease and the e.m.f induced in the inductor causes it to act as a generator i.e turning the energy stored in its magnetic field back to the source. The average power is therefore zero over a cycle.

#### Example 11.5

A 4.0 H iron core inductor is connected in series with a  $300 \Omega$  resistor to a 240V, 50Hz power supply.

- Using standard symbols draw the circuit used.
- Find the reactance of the inductor.

**Solution**

(a)

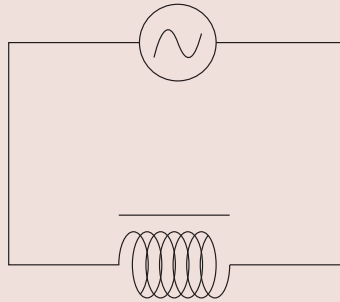


Fig. 11.23

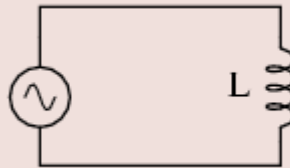
(b) (i) Reactance  $X_L = 2\pi fL = 2 \times 50 \text{ s}^{-1} \times 4 \text{ H} \times \pi = 1256 \Omega$ **Example 11.6**In a purely inductive AC circuit,  $L = 25.0 \text{ mH}$  and the r.m.s voltage is  $150 \text{ V}$ .

Fig. 11.24: An inductor connected to an a.c supply

- (a) Calculate the inductive reactance and rms current in the circuit if the frequency is  $60.0 \text{ Hz}$ .
- (b) Suppose the frequency increases to  $6.00 \text{ kHz}$ ? What happens to the rms current in the circuit?

**Solution**(a) inductive reactance  $X_L = 2\pi fL = 25.0 \times 10^{-3} \times 2\pi \times 60 = 9.42 \Omega$ 

The r.m.s current is  $I_{\text{r.m.s}} = \frac{V_{\text{r.m.s}}}{X_L} = \frac{150 \text{ V}}{9.42 \Omega} = 15.9 \text{ A}$

- (b) If the frequency increases, the inductive reactance increases because the current is changing at a higher rate. The increase in inductive reactance results in a lower current. We can find the new inductive reactance:

$$X_L = L\omega = 25.0 \times 10^{-3} \times 2\pi \times 60 \times 10^3 = 9.42 \Omega$$

The new current is  $I_{\text{r.m.s}} = \frac{V_{\text{r.m.s}}}{X_L} = \frac{150}{942} = 0.159 \text{ A}$

### Exercise 11.3

- A pure inductance of 1 henry is connected across a 110V, 70Hz source.
  - reactance of the circuit is 440
  - current of the circuit is 0.25 A
  - reactance of the circuit is 880
  - current of the circuit is 0.5 A
- A coil of inductance 5.0 mH and negligible resistance is connected to an oscillator giving an output voltage  $E = (10V) \sin \theta$ . Which of the following is correct
  - for  $f = 1000 \text{ s}^{-1}$  current is 225 A
  - for  $f = 500 \text{ s}^{-1}$  current is 4 A
  - for  $f = 100 \text{ s}^{-1}$  current is 2.25 A
  - for  $f = 1000 \text{ s}^{-1}$  current is 4 A
- With increase in frequency of an a.c supply, the inductive reactance
  - decreases.
  - increases directly proportional to frequency.
  - increases as square of frequency.
  - decreases inversely with frequency.
- An a.c voltage of 50 Hz is connected to an inductor of 2 H. A current of  $I_{\text{r.m.s.}}$  frequency of the voltage  $V$  is changed to 400 Hz keeping the magnitude of  $V$  the same. In terms of  $I$ , give the magnitude and direction of current now flowing in the coil.
- An inductor of 2 H is connected to a  $12 \text{ V}_{\text{r.m.s.}}$  mains supply  $f = 50 \text{ Hz}$ 
  - Find the current flowing through it.
  - What current flows when the inductance is increased to 6 H.
- For the circuit shown in Fig. 11.25 below, find the current in the circuit.

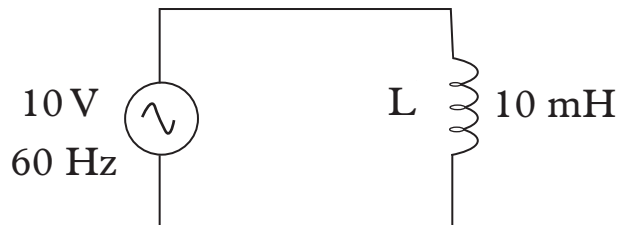


Fig. 11.25: An inductor connected to an a.c supply

## 11.7 Resistor, inductor and capacitor (RLC) in series with an a.c power supply.

### Activity 11.9

To demonstrate the behavior of a resistor (R) Inductor (L) and capacitor when they are connected in series with an A.C power supply.

#### Materials

- A carbon resistor
- Inductor
- Low range (mp) centre zero ammeter
- Low frequency generator
- Capacitor
- Low range (mv) centre – zero voltmeter
- Resistor
- Connecting wires

#### Steps

- Set up the circuit as shown in Fig. 11.26

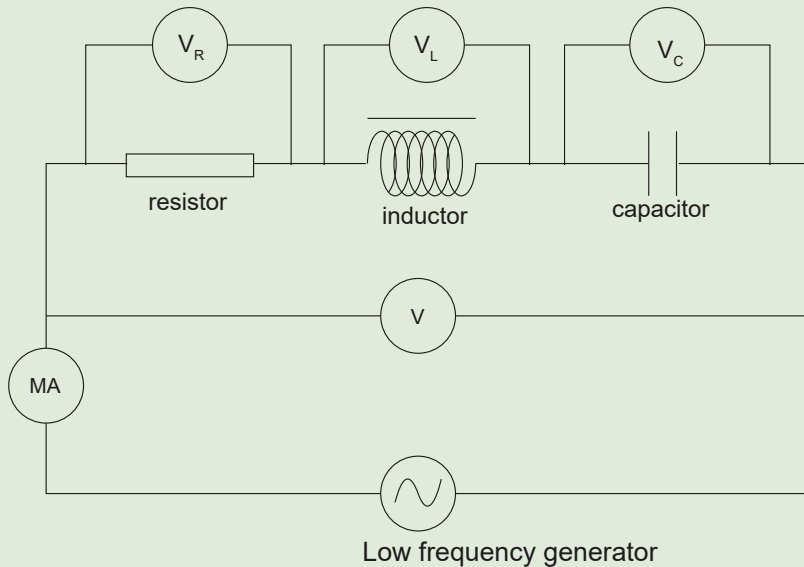


Fig. 11.26 RLC in series

- Make sure the low frequency generator is set to its minimum value.
- Switch on the mains and then the generator.
- Adjust the generator until the four voltmeters and the milliammeter are active.
- Record the value of  $V_R$ ,  $V_L$  and  $V_C$  and fill Table 11.4.
- Record what happen to the current on the frequency is increased.
- Find from the internet how the RLC series may be applied.

Table 11.4

	$F H_3$	$I_{MA}$	$V_R$ (V)	$V_L$ (V)	$V_C$ (V)	$(V_L - V_C)^2 + V^2 R$	$V^2$ (V <sup>2</sup> )
1							
2							
3							
4							
5							

When a resistor, capacitor and inductor are connected in series with an a.c. voltage supply, they form circuit called series **RLC circuit** (Fig 11.27)

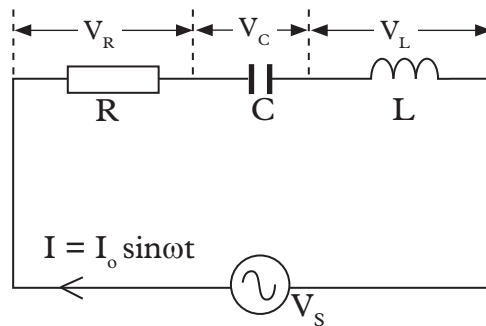


Fig. 11.27: Series RLC circuit

Since these three components are in series, the current through each of them is the same

$$I_R = I_L = I_C = I = I_o \sin \omega t$$

Let  $V_R$  be the voltage across resistor, R.

$V_L$  be the voltage across inductor, L.

$V_C$  be the voltage across capacitor, C.

$X_L$  be the inductive reactance.

$X_C$  be the capacitive reactance.

R be the resistance of the resistor.

Since for a resistor the voltage is in-phase with the current, for inductor the voltage leads the current by  $90^\circ$  and for capacitor, the voltage lags behind the current by  $90^\circ$ ; the total voltage in the RLC circuit is *not equal to algebraic* sum of voltages across the resistor ( $V_R$ ), inductor ( $V_L$ ) and capacitor ( $V_C$ ). In other words, these voltages are not in phase with each other; hence cannot be added arithmetically.

The total voltage is actually the *vector sum* of these three voltages.

Fig. 11.28 shows the phasor diagram for the three voltages with the current as the reference (because circuit the current is the same in all components). It shows the vector addition of the three voltages

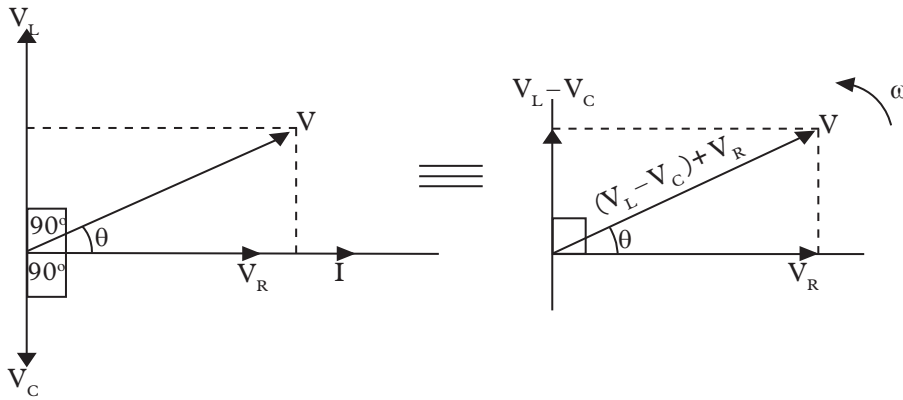


Fig. 11.28: Phasor diagram for vector addition of  $V_R$ ,  $V_L$  and  $V_C$ .

The total voltage  $V$  is given by:

$$V^2 = V_R^2 + (V_L - V_C)^2$$

Where  $V_R = IR$ ,  $V_L = IX_L$ ,  $V_C = IX_C$ ,

### The Impedance for a Series RLC Circuit

The impedance  $Z$  of a series RLC circuit is the opposition to the flow of current due the resistance  $R$ , inductive reactance,  $X_L$  and capacitive reactance,  $X_C$ .

We know that :

$$V^2 = V_R^2 + (V_L - V_C)^2$$

Substituting for  $V_R = IR$ ,  $V_L = IX_L$ ,  $V_C = IX_C$ , we get

$$V^2 = (IR)^2 + (IX_L - IX_C)^2$$

This equations simplifies to

$$V^2 = I^2 [R^2 + (X_L - X_C)^2]$$

$$\Rightarrow \frac{V^2}{I^2} = R^2 + (X_L - X_C)^2 \quad (\text{Dividing by } I^2 \text{ (both sides)})$$

$$\Rightarrow \frac{V}{I} = \sqrt{R^2 + (X_L - X_C)^2} \quad (\text{Finding square roots both sides})$$

From this equation we get other equations like

$$I = \frac{V}{\sqrt{R^2 + (X_L - X_C)^2}}$$

$$\text{And, } Z = \sqrt{R^2 + (X_L - X_C)^2} \quad (\text{since } \frac{V}{I} = Z)$$

Fig. 11.29 shows the phasor diagram for the vector addition of  $R$ ,  $X_L$  and  $X_C$  to get  $Z$

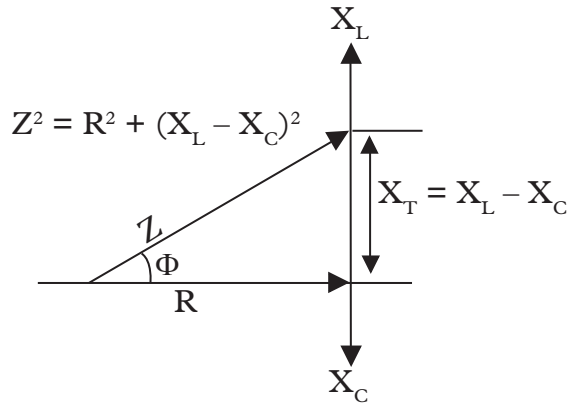


Fig. 11.29: Phasor diagram for vector addition of  $R$ ,  $X_L$  and  $X_C$ .

Since  $X_L = L\omega$  and  $X_C = \frac{1}{C\omega}$ , then the equation  $Z = \sqrt{R^2 + (X_L - X_C)^2}$  is also expressed as

$$Z = \sqrt{\left(R^2 + \left(L\omega - \frac{1}{C\omega}\right)^2\right)}$$

### Activity 11.10

To show the variation of current with frequency in an RLC series circuit

#### Materials

- Milliammeter
- Inductor
- Variable capacitor
- Signal generator (0-100 Hz: 5V)

#### Steps

1. Connect the circuit shown in fig. 11.30.

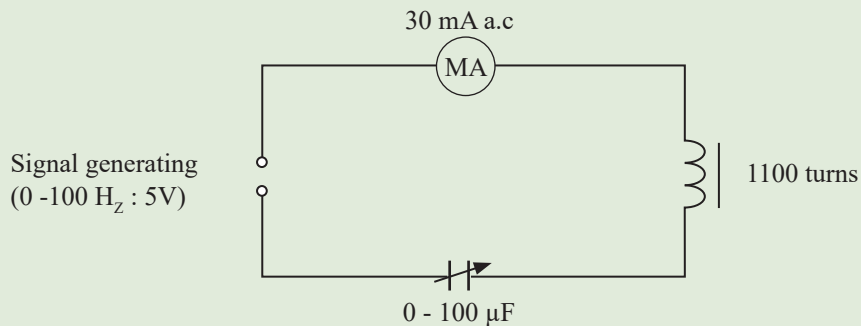


Fig. 11.30:

2. Starting with 0 Hz increase the frequency.
3. Observe and explain what happens to the milliammeter.



The graph of current against frequency for an RLC is as shown in Fig. 11.31

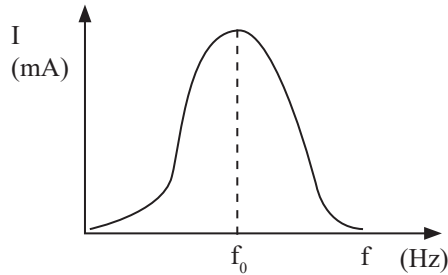


Fig. 11.31: resonant frequency  $f_0$

The frequency at which the current is maximum is called resonant frequency. This occurs when  $X_L = X_C$

$$\therefore 2\pi f_0 L = \frac{1}{2\pi f_0 C}$$

$$f_0 = \frac{1}{2\pi\sqrt{LC}} \implies \omega_0 = 2\pi f_0 = \frac{1}{\sqrt{LC}}$$



A good example of application of RLC is the tuning circuit of a radio.

### Example 11.7

A series RLC circuit with  $L = 160 \text{ mH}$ ,  $C = 100 \text{ }\mu\text{F}$ , and  $R = 40.0 \text{ }\Omega$  is connected to a sinusoidal voltage  $V(t) = 40\sin\omega t$ , with  $\omega = 200 \text{ rad/s}$ .

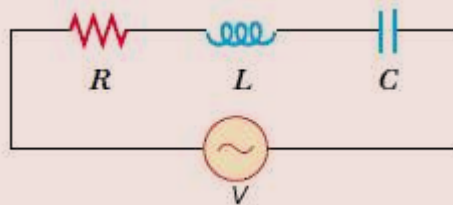


Fig. 11.32: An RLC circuit

- (a) What is the impedance of the circuit?  
 (b) Let the current at any instant in the circuit be  $I(t) = I_0 \sin\omega t$ . Find  $I_0$ .

**Solution**

- (a) The impedance of a series RLC circuit is given by

$$Z = \sqrt{R^2 + \left(L\omega - \frac{1}{C\omega}\right)^2} = \sqrt{40^2 + \left(0.16 \times 200 - \frac{1}{100 \times 200}\right)^2} = 43.9 \text{ }\Omega$$

(b) The amplitude of the current is given by  $I_0 = \frac{V_0}{Z} = \frac{40}{43.9} = 0.911 \text{ A}$

### Example 11.8

An a.c generator with  $V(t) = 150\sin\omega t$  is connected to a series RLC circuit with  $R = 40.0 \Omega$ ,  $L = 80.0 \text{ mH}$ ,  $C = 50.0 \mu\text{F}$ , and  $\omega = 100 \text{ rad/s}$ .

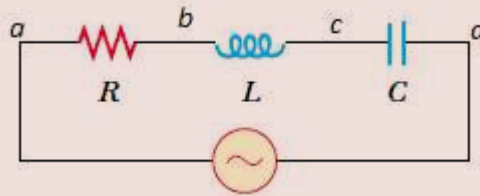


Fig. 11.33: An RLC circuit

- (a) Calculate  $V_R$ ,  $V_L$  and  $V_C$ , the maximum of the voltage drops across each circuit element.
- (b) Calculate the total potential difference across the three components between points  $a$  and  $d$ .

### Solution

(a) The inductive reactance is given by  $X_C = \frac{1}{L\omega} = \frac{1}{50 \times 100} = 200 \Omega$ ,

The capacitive reactance by given is by  $X_L = L\omega = 0.08 \times 100 = 8.0 \Omega$

The impedance of the circuit is given by  $Z = \sqrt{R + (X_L - X_C)^2}$

$$= \sqrt{40^2 + (8 - 200)^2} = 196 \Omega$$

Therefore, the corresponding maximum current amplitude is

$$I_0 = \frac{V_0}{Z} = \frac{150}{196} = 0.765 \text{ A},$$

The maximum voltage across the resistance would be the product of maximum current and the resistance:

$$V_R = IR = 0.765 \times 40 = 30.6 \Omega$$

Similarly, the maximum voltage across the inductor is

$$V_L = IX_L = 0.765 \times 8.0 = 6.12 \text{ V}$$

And the maximum voltage across the capacitor is

$$V_L = IX_C = 0.765 \times 200 = 153 \text{ V}$$

Note that the total voltage  $V_0$  is given by

$$\begin{aligned} V^2 &= V_R^2 + (V_L - V_C)^2 = 30.6^2 + (6.12 - 153)^2 \\ &= 22510.09 \\ V &= \sqrt{22510.09} = 150 \text{ V} \end{aligned}$$

### Exercise 11.4

- How much current will flow in a 100 Hz RLC series circuit if  $V_s = 20 \text{ V}$ ,  $R = 66 \text{ ohms}$ , and  $X_L = 47 \text{ ohms}$ ?
  - 1.05 A
  - 303 mA
  - 247 mA
  - 107 mA
- Draw an electric circuit with the following components; resistors, capacitors, and inductor in series. Hence, sketch a graph to show how their values change with change in a.c frequency.
- Draw an electric circuit showing an a.c source connected to a single inductor.
- A series RC circuit with  $R = 4.0 \times 10^3 \Omega$  and  $C = 0.40 \mu\text{F}$  is connected to an a.c voltage source  $V(t) = (100 \text{ V}) \sin \omega t$ , with  $\omega = 200 \text{ rad/s}$ .
  - What is the rms current in the circuit?
  - Find the voltage drop both across the resistor and the capacitor.
- A series RLC circuit with  $R = 10.0 \Omega$ ,  $L = 400 \text{ mH}$  and  $C = 2.0 \mu\text{F}$  is connected to an a.c voltage source which has a maximum amplitude  $V_0 = 100 \text{ V}$ .
  - What is the resonant frequency  $\omega_0$ ?
  - Find the rms current at resonance.
  - Let the driving frequency be  $\omega = 4000 \text{ rad/s}$ . Compute  $X_C$ ,  $X_L$  and  $Z$ .
- A series LCR circuit has a supply current  $I(t) = I_0 \sin 2\pi f t$  where  $I_0 = 0.1 \text{ A}$  and the supply frequency  $f = 50 \text{ Hz}$ . If the components have values  $R = 100 \Omega$ ,  $C = 50 \mu\text{F}$  and,  $L = 50 \text{ H}$ , calculate the impedance of the circuit and hence obtain an expression for the supply voltage.
- A resistance of  $100 \Omega$  is connected in series with a capacitor of  $25 \mu\text{F}$  and an inductor. The r.m.s voltage across the terminals of the source is  $240 \text{ V}$  and its frequency is  $800. \pi^{-1} \text{ Hz}$ . Given that  $V_R = 80 \text{ V}$ , find (a)  $Z$  (b)  $L$ .

## Unit summary and new words

- An electric symbol is a pictogram used to represent various electrical and electronic devices (such as wires, batteries, resistors, and inductor) in a schematic diagram of an electrical or electronic circuit.
- In direct current (dc), the electric charge (current) only flows in one direction. Electric charge in alternating current (ac), on the other hand, changes direction periodically. The voltage in ac circuits also periodically reverses because the current changes direction.
- A resistor is an electrical component that limits or regulates the flow of electrical current in an electronic circuit. It is also used adjust signal levels, to divide voltages, bias active elements, and terminate transmission lines, among other uses.
- A capacitor is a device used to store an electric charge, consisting of one or more pairs of conductors separated by an insulator.
- An inductor is a passive two-terminal electrical component, which resists changes in electric current passing through it. It consists of a conductor such as a wire, usually wound into a coil. Energy is stored in a magnetic field in the coil as long as current flows.
- An RLC circuit is an electrical circuit consisting of a resistor (R), an inductor (L), and a capacitor (C), connected in series or in parallel.

## Unit Test 11

For questions 1 to 3, choose the most appropriate answer.

1. What is the applied voltage for a series RLC circuit when  $I_T = 3 \text{ mA}$ ,  $V_L = 30 \text{ V}$ ,  $V_C = 18 \text{ V}$ , and  $R = 1000 \text{ ohms}$ ?
 

<b>A.</b> 3.00 V	<b>B.</b> 12.37 V
<b>C.</b> 34.98 V	<b>D.</b> 48.00 V
2. Which of the following is true about both alternating current (a.c) and direct current (d.c)?
 

<b>(i)</b> Causes heating	
<b>(ii)</b> Can be stepped up or down with transformer.	
<b>(iii)</b> Can be used to charge a battery	
<b>A.</b> (i), (ii), (iii)	<b>B.</b> (i) and (ii)
<b>C.</b> (i) and (iii)	<b>D.</b> (ii) and (iii)

3. What is the impedance of the circuit shown in Fig. 11.34 if  $\omega = 200\text{rad/s}$ ?

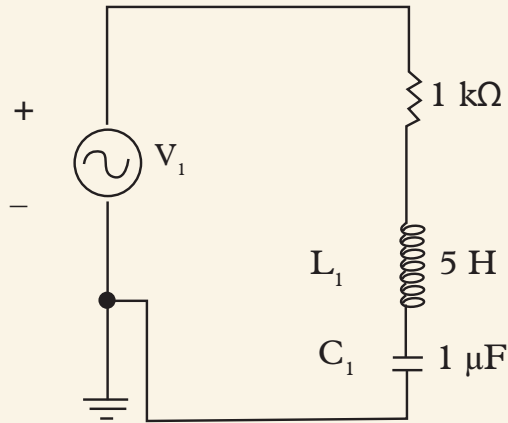


Fig. 11.34: An RLC circuit

- A.  $4123\text{ K}\Omega$                       B.  $4.123\text{ K}\Omega$   
 C.  $17\text{ m}\Omega$                          D.  $16\text{ K}\Omega$
4. (a) Briefly explain the meaning of:  
 (i) A resistor                          (ii) A capacitor  
 (iii) An inductor
- (b) State two uses of each electric component in 1 (a).

**For questions 5 and 6 calculate and indicate the most correct answer.**

5. Consider the LC circuit in Fig. 11.35. If one needs to tune this circuit to a frequency of  $84\text{ kHz}$ , and the capacitor has a capacitance  $C = 3.0\text{ }\mu\text{F}$ , what inductance ( $L$ ) is needed?

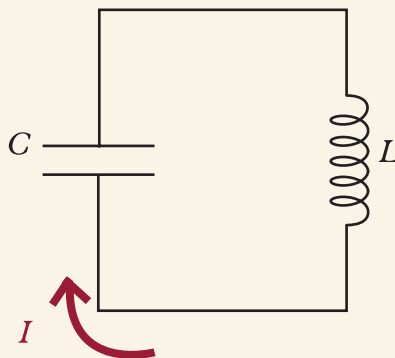


Fig. 11.35: An LC circuit

6. Consider the LC circuit shown in Fig 11.36.

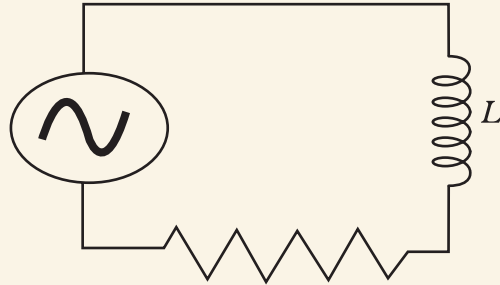


Fig. 11.36: An LC circuit

- (a) What is the impedance of the circuit if:  $f = 60 \text{ Hz}$ ,  $L = 20 \text{ mH}$ ,  $R = 4.0 \text{ }\Omega$ ?
- (b) If the r.m.s. voltage of the source is  $V_{\text{r.m.s.}} = 110 \text{ V}$ , what is the r.m.s. current?
- (c) What is the peak current?
- (d) What is the power dissipated in the resistor?
7. Consider the RLC circuit shown in Fig 11. 37.

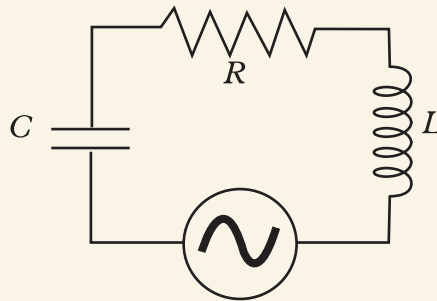


Fig. 11.37: An RLC circuit

- (a) What is the capacitance such that the current through the circuit is maximum?
- (b) What is the r.m.s. current through the circuit?
- (c) Find the capacitance that would make the impedance equal to  $8 \text{ }\Omega$ .

**Key Unit Competence**

By the end of this unit learner should be able to explain refraction of light phenomenon

**Learning objectives****Knowledge and understanding**

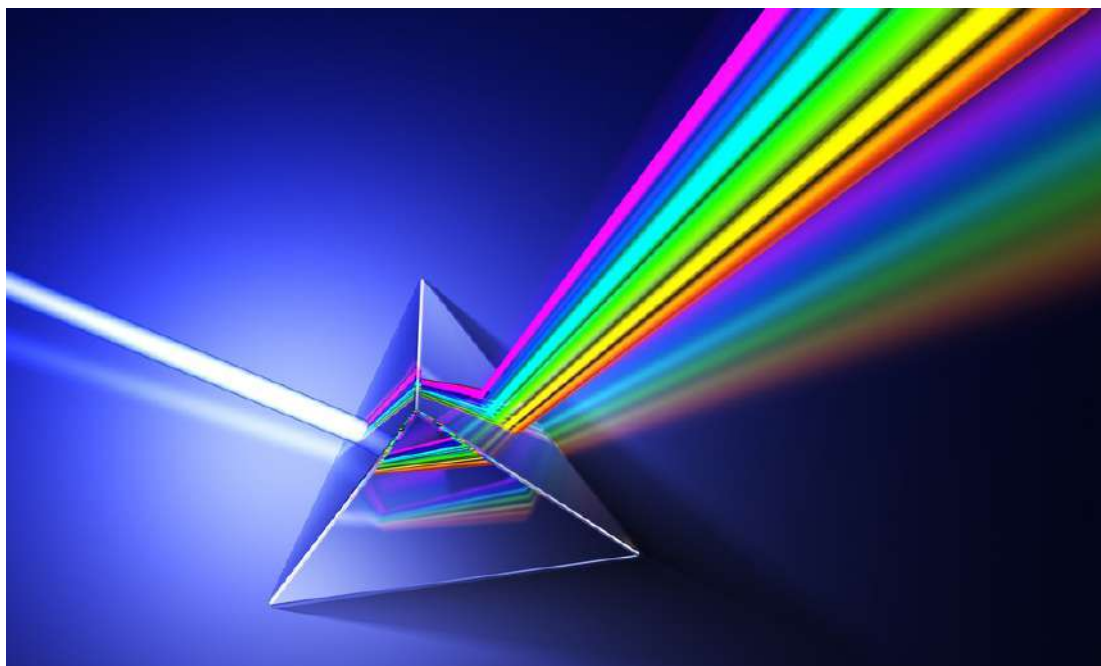
- Recall the propagation of light and reflection.
- Explain phenomenon of refraction of light.
- State the laws of refraction of light.
- Explain total internal reflection of light and its application.
- Explain how spherical thin lenses form images.
- Explain defects of lenses and how they occur.
- Describe the spectrum of light by glass prism.
- Outline different applications of refraction of light.

**Skills**

- Analyse graphical construction of images formed by converging or diverging thin lens.
- Evaluate the correction of defects in lenses.
- Describe types of light refraction.
- Analyse the dispersion of light by glass prism.
- Measure refractive index.

**Attitude and value**

- Appreciate the formation of real and virtual image by lenses.
- Appreciate the applications thin of lenses.
- Appreciate different colours in white light.
- Internalize the formation of a rainbow.
- Appreciate the bending of light when it moves from one medium to another.



## Introduction

### Unit focus activity

To explain the phenomenon of refraction of light

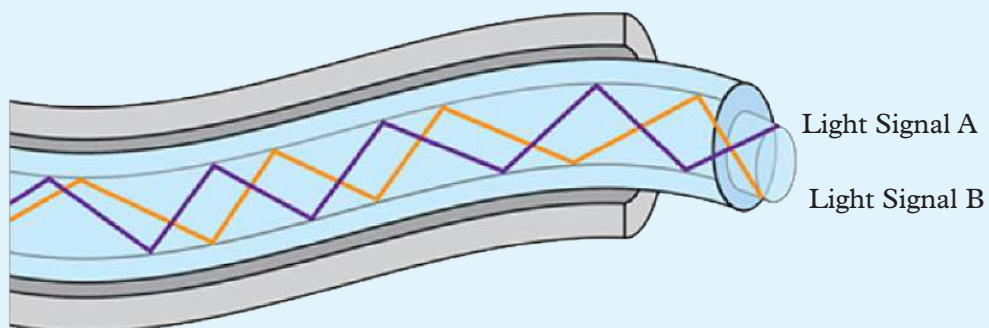
#### Materials

- Microscope
- Optical fibre cable

#### Steps

##### Part 1

1. The fig 12.1 shows light signals being transmitted through an optical fibre.



*Fig. 12.1 : Optical fibre transmitting light signals*



2. Name the phenomenon of light used in it.
3. Briefly describe the working principle of optical fibres.

### Part 2

Your teacher will provide you with a microscope as the one shown in fig. 12.2.



Fig. 12.2: Microscope

#### Precaution!

Handle the microscope with a lot of care! It is costly to replace once damaged.

4. Make a specimen from a plant and observe the tissues with unaided eyes then using a microscope. Do you notice any difference? Comment.
5. With the help of a simple light rays diagram, describe how the microscope magnifies the image of very tiny objects.

We have learnt that light travels in a straight line. We also looked at reflection of light at plane surfaces and characteristics of images formed under the plane mirror. In this unit, we will introduce another property of light. In general life, we have observed that:

1. A thin rod dipped obliquely into water appears to be bent at the water surface.

2. A pool of water appears to be shallower than it actually is.
3. A colourful rainbow is formed in the atmosphere usually after some rainfall.
4. A ‘shimmering’ pool of water seems to be ahead of a traveller on tarmac road or desert sand on a hot day.

Explain these phenomena to your classmates.

These and many other similar effects are caused by a property of light called *refraction* of light.

## 12.1 Phenomena of refraction of light

The following activities will help us illustrate the refraction of light.

### 12.1.1 Demonstrations of refraction of light

#### Activity 12.1

#### To describe the refraction of light

##### Materials

- Plastic ruler
- Water in a transparent container

##### Steps

1. Dip a plastic ruler into a transparent container of clean water
2. View the ruler from the top and the side of the container (Fig. 12.3). What do you observe on the shape of the ruler? Explain.

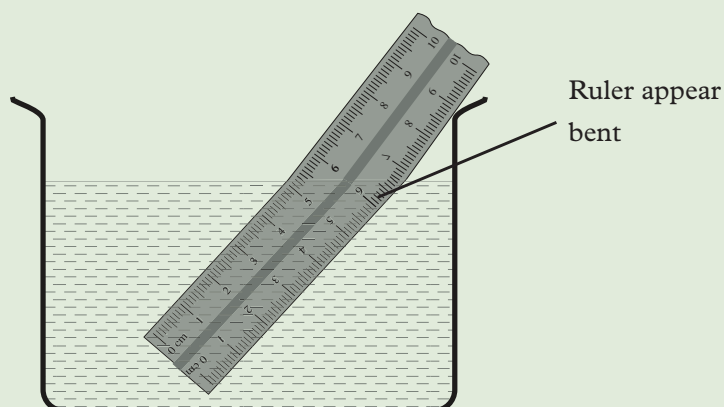


Fig. 12.3: Appearance of a ruler in water.

The ruler appears to be bent at the point where it enters into water. This is because light rays change direction (bend) when traveling from air to water. Therefore, a ruler appears bent due to refraction of light.

### Activity 12.2

### To demonstrate how light rays travels using a rectangular glass block

#### Materials

- A rectangular glass block.
- A ray box.

#### Steps

Pass a narrow beam of light through a rectangular glass block in a semi-dark room and observe the path of light (Fig. 12.4).

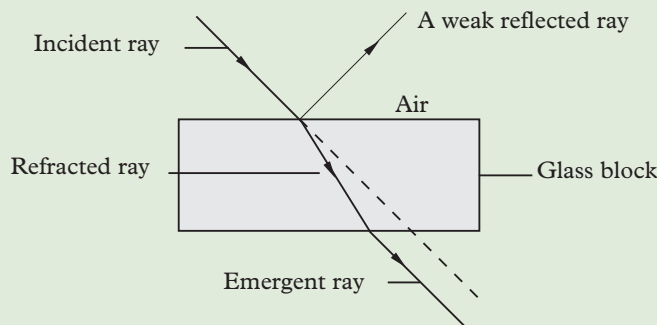


Fig. 12.4: A ray of light passing through a rectangular glass block.

The direction of the ray of light inside the glass changes. Some of the light is also reflected from the surface of glass. The emergent ray is parallel to the incident ray. In all the above experiments, when light travels from air to another medium like water or glass and vice versa, there is a change in the direction of the path of light at the boundary of the two media. This property of light is called *refraction*.

When light travels from one medium to another of different optical density, it bends. The bending of light is called *refraction*.

Refraction of light is the bending of light rays when they travel from one medium to another of different optical density. Also, refraction is the change of direction when light rays travel from one medium to another.

Refraction is caused by the change of velocity of light as it travels from one medium to another. Experiments show that the velocity of light in air (vacuum) is  $3 \times 10^8$  m/s. The velocity of light is less in all the other media. Hence air is considered as an optically *rarer medium*. All the other media, are considered as optically *denser media than air*.

### 12.1.2 Terms associated with refraction of light

Consider a rectangular glass block ABCD (Fig. 12.5). AB is a boundary that separates the two media i.e. air and glass. Ray PQ travelling in air is incident at the point Q at the boundary. On entering the glass, the ray travels along a path QR (Activity 12.1). NQM is the the normal drawn at Q to the line AB.

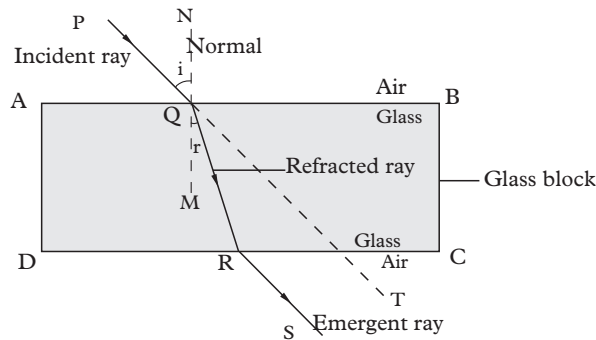


Fig. 12.5: Terminologies used in refraction of light.

The ray PQ is the *incident ray* and the ray QR is the *refracted ray*. The angle PQN, between the incident ray and the normal, is the *angle of incidence*,  $i$ . The angle RQM, between the refracted ray and the normal, is the *angle of refraction*,  $r$ . The ray RS is the *emergent ray*. As seen in Fig. 12.5 the emergent ray RS is parallel to the incident ray PQ, shown by the dotted line QT.

A ray passing from a rarer medium to a denser medium bends *towards the normal*. On the other hand, a ray passing from a denser medium to a rarer medium bends *away from the normal* (Fig. 12.5).

At the boundary or the surface that separates the two media, there is a change in velocity of light that causes the change of direction. However, if light travels at right angles to the boundary as shown in Fig. 12.6 (c) there is no change in direction. Light continues to travel in a straight line but the speed of light is reduced in the glass. This is, sometimes, referred to as the *normal refraction*.

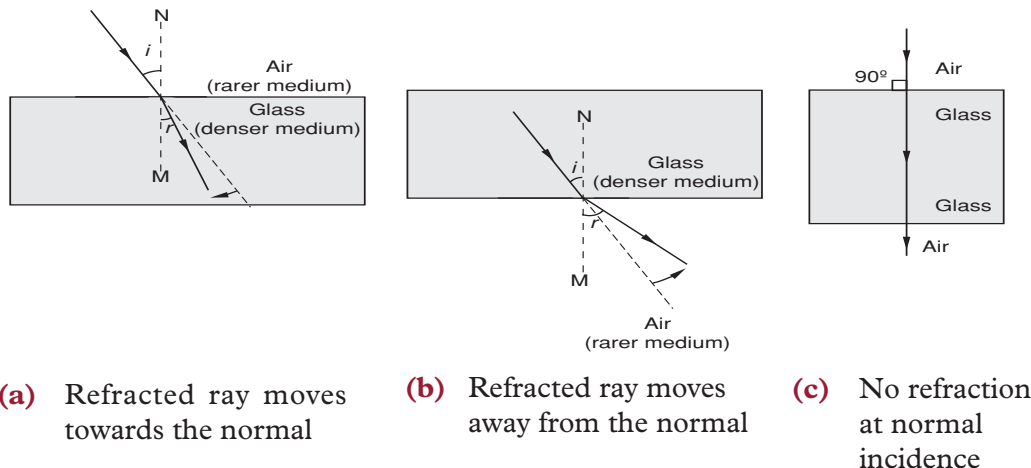


Fig. 12.6: Refraction of light in different media

### Exercise 12.1

- Define the term:
  - Refraction of light
  - Angle of incidence
- Explain why light bends when it travels from one medium to another.
- Draw diagrams to illustrate refraction for a ray of light on:
  - Glass – air boundary
  - Water – air-glass boundaries
  - Water – glass boundary
- Complete the ray in Fig. 12.7 to show refraction.

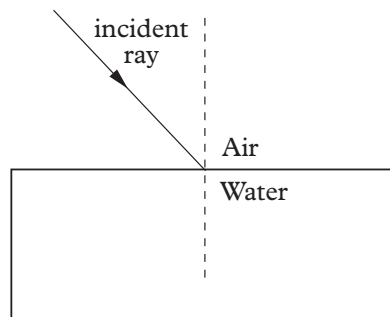


Fig. 12.7: Refraction of light

#### 12.1.3 Laws of refraction of light

Many scientists have contributed in the study of refraction of light. One such scientist who discovered the relationship between the angle of incidence and the angle of refraction was **Willebrord Snell**.

The following experiments will help in establishment of the relationship between angle of incidence and the angle of refraction.

#### Activity 12.3

To investigate the relationship between the angle of incidence and the angle of refraction

##### Materials

- A thick glass block
- A ray box
- A paper protractor

##### Steps

- Fix on the top of a table a thin circular “paper protractor” graduated in degrees as shown in Fig. 12.8.

- Place a rectangular glass block ABCD such that the edge AB coincides with the 90°–90° mark of the protractor. The line along 0°–0° mark represents the normal NQM at Q.

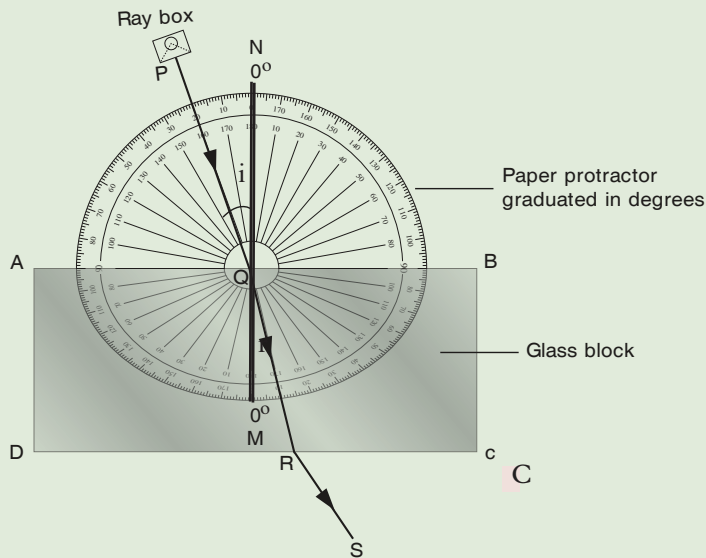


Fig. 12.8: Relationship between the angle of incidence and the angle of refraction

- Using a ray box, in a semi-dark room, pass a ray of light through the glass block at an angle of incidence,  $i$ , say  $20^\circ$ . Measure the angle of refraction,  $r$ .
- Repeat the experiment for different angles of incidence and measure the corresponding angles of refraction.
- Record the results in a table similar to Table 12.1. Complete the other columns in the table. What do you notice about the ratio of  $\sin i$  to  $\sin r$ , i.e.  $\frac{\sin i}{\sin r}$ ?

Table 12.1

$i^\circ$	$r^\circ$	$\sin i$	$\sin r$	$\frac{\sin i}{\sin r}$

**In summary**

- The ratio  $\frac{\sin i}{\sin r}$  is *practically* a constant.
- The incident ray, the refracted ray and the normal all, lie in the same plane at the point of incidence.

The two observations constitute the laws of refraction.

**Laws of refraction**

1. The incident ray, the refracted ray and the normal, at the point of incidence, all lie in the same plane.
2. The ratio of the sine of the angle of incidence to the sine of the angle of refraction is a constant for a given pair of media (Snell's law) i.e

$$\frac{\sin i}{\sin r} = \text{constant}$$

The expression  $\frac{\sin i}{\sin r} = \text{constant}$  is the mathematical expression of Snell's law.

**Activity 12.4****To verify Snell's law using pins and a glass block****Materials**

- White plain paper
- A ruler
- A glass block
- Four pins
- Softboard

**Steps**

1. Fix a white plain paper on a softboard. Draw a line XY and mark its midpoint Q. At Q draw a normal NQM perpendicular to XY and a line PQ such that the angle of incidence,  $i$ , ( $\angle PQN$ ) is  $20^\circ$ .
2. Place a rectangular glass block such that the midpoint of the edge AB coincides with the midpoint Q of the line XY (Fig. 12.9). Draw the outline of the glass block ABCD.
3. Stick two pins  $O_1$  and  $O_2$ , called the *object pins* on the straight line PQ vertically into the softboard about 5.0 cm apart. View from the side CD and look for the images of the first two pins.
4. Keeping the eye along the plane of the paper, move the head to and fro slowly until in one particular position the images of the two pins lie on a straight line.

5. Fix a third pin  $S_1$  called the *search pin*, such that this pin and the images of the first two pins as seen through the glass block lie along the same straight line.
6. Repeat the above procedure with the fourth pin  $S_2$ , so that the images of the pins  $O_1$  and  $O_2$  and the search pins  $S_1$  and  $S_2$  lie along the same straight line.
7. Using a pencil, mark the positions of the four pins with a small circle and remove the pins and the glass block.
8. Join the points  $S_2$  and  $S_1$  to meet the line DC at R. Join points  $O_2$  and  $O_1$  to meet at Q. Join Q to R to make line QR. QR is the refracted ray in the glass for the incident ray PQ in air. Measure the angle of refraction,  $r$ , ( $\angle MQR$ ).

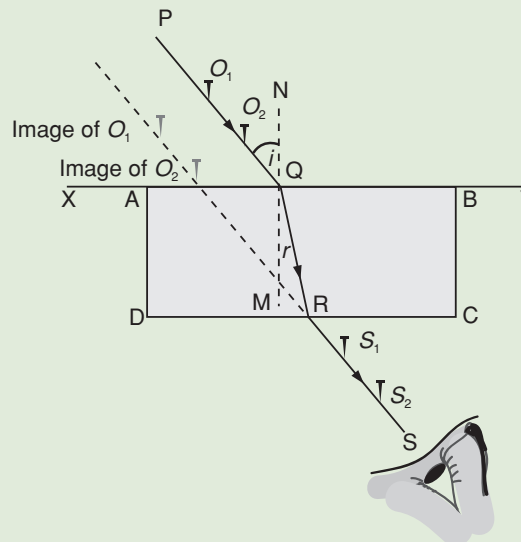


Fig. 12.9: Verifying Snell's law.

9. Repeat the experiment for different angles of incidence and record the readings in a table similar to Table 12.1.
10. What do you observe on the column  $\frac{\sin i}{\sin r}$ ? What does it represent?

Once again it is seen that the ratio  $\frac{\sin i}{\sin r}$  is a constant for the two given media.

Draw a graph of  $\sin i$  (y-axis) against  $\sin r$  (x-axis).

The graph drawn is a straight line passing through the origin as shown in Fig. 12.10. The gradient of the graph gives  $\frac{\sin i}{\sin r}$  which is a constant.

Snell's law states that for two refracting media, the ratio of the sine of the angle of incident to the sine of the angle of refraction is a constant.



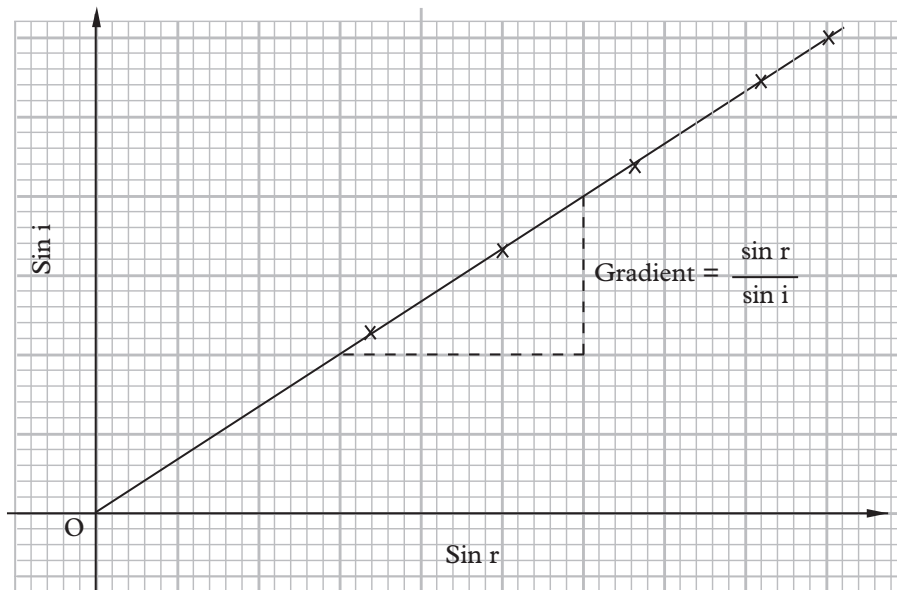


Fig. 12.10: Graph of  $\sin i$  against  $\sin r$

### 12.1.4 Refractive index

The refractive index ( $\eta$ ) is the measure of bending of light i.e. is the ratio of sine of angle of incident to the sine of angle of refraction (hence Snell's law).

Snell's law can also be stated as  $\frac{\sin i}{\sin r} = \text{a constant}$ .

This constant is known as *refractive index*,  $\eta$  or *index of refraction*. Therefore,

Refractive index ( $\eta$ ) =  $\frac{\sin i}{\sin r}$ . It has no units.

Since refractive index is the property of two media, it is necessary to indicate them. If, for example, light travels from air to glass the ratio  $\frac{\sin i}{\sin r}$  is found to be 1.50. This is the refractive index of glass with respect to air. We can rewrite this using the following symbols.

$${}_{\text{air}}\eta_{\text{glass}} = 1.50 \quad \text{i.e. } {}_a\eta_g = 1.50$$

The *absolute refractive index* of a medium is the value of  $\eta$  when the first medium is a vacuum.

The absolute refractive index of a medium  $\eta = \frac{\sin i}{\sin r}$

Where the angle of incidence is in vacuum and the angle of refraction is in the medium

The difference between the refractive indices of air and vacuum is very small and hence the refractive index of a medium with respect to air is taken as the absolute refractive index (unless extreme accuracy is required).

$$\text{Refractive index of a medium } (\eta) = \frac{\sin i}{\sin r}$$

Where the angle of incidence is in air and the angle of refraction is in the medium

The refractive index of a medium can also be expressed in terms of velocity of light in the media.

Refractive index is the ratio of velocity of light in a vacuum to velocity of light in a medium.

$$\text{Refractive index of a medium} = \frac{\text{velocity of light in vacuum}}{\text{velocity of light in the medium}}$$

$$\eta = \frac{c}{v}$$

Table 12.2 gives the refractive indices of some substances with respect to air (taking the refractive index of air as 1.00). Materials with higher refractive indices bend light more than those with lower refractive indices.

Table 12.2

Solid	refractive index ( $\eta$ )	Liquid	refractive index ( $\eta$ )
Ice	1.31	Water	1.33
Glass (crown)	1.50	Alcohol	1.36
Glass (flint)	1.65	Paraffin	1.44
Ruby	1.76	Glycerine	1.47
Diamond	2.40	Turpentine	1.47

### Example 12.1

A ray of light passing from air to glass is incident at an angle of  $30^\circ$ . Calculate the angle of refraction in the glass, if the refractive index of glass is 1.50.

### Solution

$$\text{Refractive index of glass } {}_a\eta_g = \frac{\sin i}{\sin r}$$

$$\therefore \sin r = \frac{\sin i}{\eta_g} = \frac{\sin 30^\circ}{1.50} = \frac{0.50}{1.50} = 0.33$$

$$\therefore r = 19.5^\circ$$

The angle of refraction in glass is  $19.5^\circ$

**Example 12.2**

In Fig. 12.11 calculate the refractive index of glass.

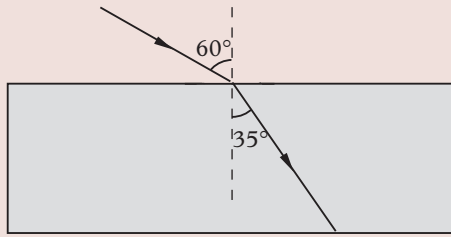


Fig. 12.11: Glass block

**Solution**

$$\text{Refractive index of glass } ({}_a\eta_g) = \frac{\sin i}{\sin r} = \frac{\sin 60^\circ}{\sin 35^\circ}$$

$${}_a\eta_g = \frac{0.866}{0.574} = 1.51$$

The refractive index of glass is 1.51.

**Example 12.3**

The angle of incidence for a ray of light passing from air to water is  $30^\circ$  and the angle of refraction is  $22^\circ$ . Calculate the refractive index of water.

**Solution**

$$\eta_{\text{water}} = \frac{\sin i}{\sin r} = \frac{\sin 30^\circ}{\sin 22^\circ} = \frac{0.500}{0.375} = 1.33$$

$\therefore$  The refractive index of water is 1.33 (hence  ${}_a\eta_w = 1.33$ )

**Example 12.4**

Calculate the refractive index of water, given that the velocity of light in air is  $3 \times 10^8$  m/s and velocity of light in water is  $2.25 \times 10^8$  m/s.

**Solution**

$$\eta_w = \frac{\text{velocity of light in air}}{\text{velocity of light in water}} = \frac{3 \times 10^8 \text{ m/s}}{2.25 \times 10^8 \text{ m/s}} = 1.33$$

**Example 12.5**

The velocity of light in glass is  $2.0 \times 10^8$  m/s. Calculate (a) the refractive index of glass and (b) the angle of refraction in the glass for a ray of light passing from air to glass at an angle of incidence of  $40^\circ$ .

**Solution**

$$(a) \quad {}_a n_g = \frac{C_{\text{air}}}{V_{\text{glass}}} = \frac{3 \times 10^8 \text{ m/s}}{2 \times 10^8 \text{ m/s}}$$

$${}_a n_g = 1.50$$

$$(b) \quad {}_a n_g = \frac{\sin i}{\sin r} = 1.50$$

$$\sin r = \frac{\sin i}{1.50} = \frac{\sin 40^\circ}{1.50} = 0.428$$

$$r = \sin^{-1} 0.428$$

$$= 25.4^\circ$$

**12.1.5 The principle of reversibility of light**

Just like light rays travel from medium 1 to a medium 2, it also travels in the reverse direction i.e travel from the medium 2 to medium 1. This is known as *the principle of reversibility of light*. It states that light will follow exactly the same path if its direction of travel is reversed. The following experiment will help us to establish that light rays can travel from a medium to air or vacuum and back through the same path.

**Activity 12.5****To verify the principle of reversibility of light****Materials**

- A glass-air boundary
- Plane mirror

**Steps**

1. Place a plane mirror M perpendicular to the refracted ray of light QR as shown in Fig. 12.12.

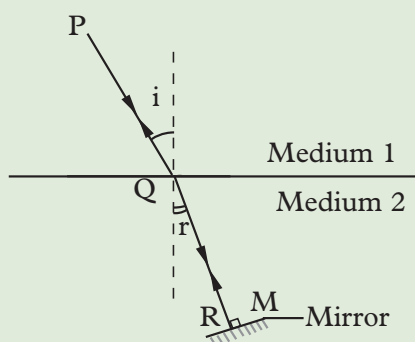


Fig. 12.12: The principle of reversibility of light

2. Observe what happens to the reflected ray. Explain your observation.

In this activity, the reflected ray is reversed along RQ and is refracted through QP in medium 1.

This means that the ray retraces its entire path. This is the principle of *reversibility of light*.

$$\text{From Snell's law, } {}_1\eta_2 = \frac{\sin i}{\sin r}$$

$$\text{For the reversed path, } {}_2\eta_1 = \frac{\sin r}{\sin i}$$

By multiplying the respective sides of the above two equations we get

$${}_1\eta_2 \times {}_2\eta_1 = \frac{\sin i}{\sin r} \times \frac{\sin r}{\sin i} = 1$$

$${}_1\eta_2 \times {}_2\eta_1 = 1.$$

$$\text{Therefore, } {}_1\eta_2 = \frac{1}{{}_2\eta_1}$$

The refractive index for a ray moving from air to water is 1.33 but when the ray moves from water to air the refractive index is  $\frac{1}{1.33} = 0.75$ .

### Exercise 12.2

- Define the term refractive index.
- (a) State the laws of refraction.  
(b) Describe an experiment to determine the refractive index of a rectangular glass block.
- A ray of light is passing from air into water along PQ. The ray strikes the bottom surface at T instead of R as shown in Fig. 12.13. Calculate:

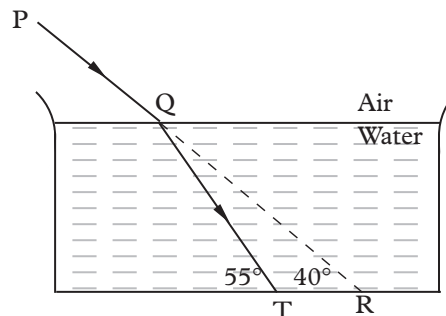


Fig. 12.13: A ray passing air-water interface

- The angle of incidence
- The angle of refraction
- The refractive index of water.

4. Copy and complete Fig. 12.14 to show the path of light through and out of the glass block of refractive index 1.50.

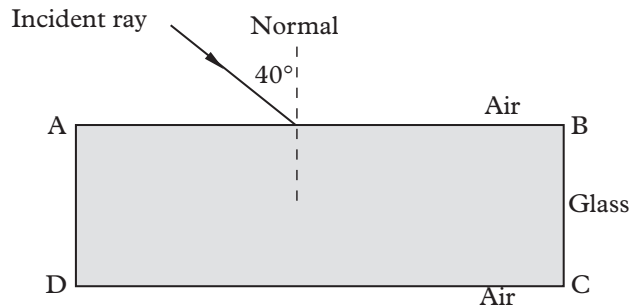


Fig. 12.14: Glass block

5. Light travels through glass of refractive index 1.60 with a speed of  $v$  m/s. Calculate the value of  $v$ , if the speed of light in air is  $3.0 \times 10^8$  m/s.
6. In a semicircular glass block for the incident ray PQ inside glass, QR is the refracted ray in air as shown in Fig. 12.15.

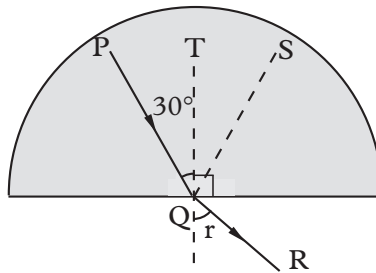


Fig. 12.15: Semi circular glass block

- (a) What do the dotted lines QS and QT represent?
- (b) Calculate the angle of refraction,  $r$ , in air, if the refractive index of glass is 1.50.
7. State Snell's law of refraction. Describe an experiment to verify it.
8. Table 12.3 shows the angles of incidence  $i$  and the angles of refraction,  $r$ , when light passes from air to glass. Complete the table and draw a graph of  $\sin r$  (y-axis) against  $\sin i$  (x-axis). From the graph determine the refractive index of glass.

Table 12.3

$i^\circ$	$r^\circ$	$\sin i$	$\sin r$
15	10		
30	19		
45	28		
60	35		

### 12.1.6 Real and apparent depth

#### Activity 12.6

To describe real and apparent depth

#### Materials

- Water in a transparent container
- A coin

#### Steps

1. Place the coin at the bottom of the container with water.
2. From the top position your eyes perpendicularly to the coin and look at it. Do you see the coin? Where is it?
3. Now shift eye to an angle and look again at the coin. Where do you see it?
4. Explain your observations in steps 2 and 3.
5. Discuss with your classmates what real and apparent depth are. Deduce the relationship between the two.

Fig. 12.16 shows how to locate the image of an object in a denser medium (glass) using a ray diagram.

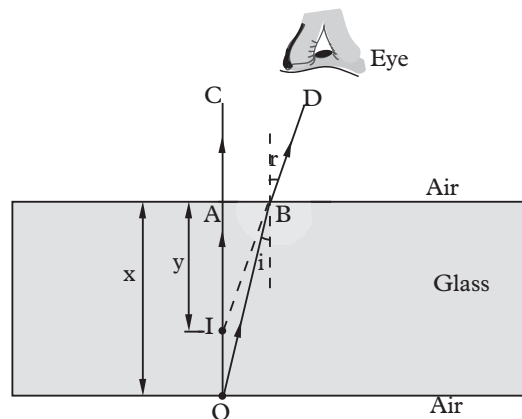


Fig. 12.16: Image formation in a glass block

A ray OA is incident along the normal. The ray goes undeviated as AC at the surface of the two media. Another ray OB, incident obliquely at B and close to A bends away from the normal and proceeds along BD. When DB is produced backwards, it meets OC at I. This is the position of the virtual image of the object O. OA ( $x$ ) is the *real depth* of the object below the surface of separation. IA ( $y$ ) is the *apparent depth* of the image below the surface of separation.

## The relationship between refractive index, real depth and apparent depth

Fig. 12.17 shows the image I of an object O inside water. Point B is very close to point A.

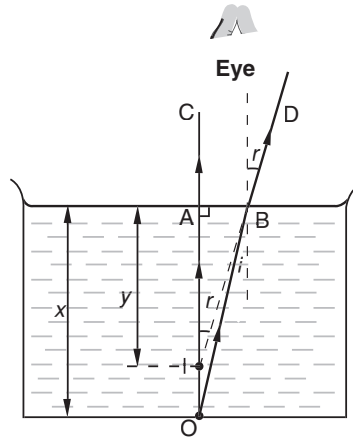


Fig. 12.17: Real and apparent depth

From the Snell's law  ${}_w n_a = \frac{\sin i}{\sin r}$

By the principle of reversibility of light,

$${}_a n_w = \frac{\sin r}{\sin i}$$

$\angle AOB = i$  (alternate angles);  $\angle AIB = r$  (corresponding angles)

$$\sin r = \frac{AB}{IB} \quad \text{and} \quad \sin i = \frac{AB}{OB}$$

$${}_a n_w = \frac{\sin r}{\sin i} = \frac{\frac{AB}{IB}}{\frac{AB}{OB}} = \frac{OB}{IB}$$

Since B is very close to A then  $\frac{OB}{IB} = \frac{OA}{IA}$

Therefore,  ${}_a n_w = \frac{OA}{IA} = \frac{x \text{ (real depth)}}{y \text{ (apparent depth)}}$

$$\text{hence } {}_a n_w = \frac{\text{real depth}}{\text{apparent depth}}$$

This relation can be used to determine the refractive index of a transparent solid or a liquid. Since the refractive index of a denser medium is greater than 1,  $i$  is always less than  $r$ . Thus the image of an object situated in a denser medium



appears to be raised towards the surface. For example, if a pool of water is 4 m deep, the apparent depth of the pool is given by

$$y = \frac{x}{\eta} = \frac{4.00}{1.33} = 3.0 \text{ m}$$

### Activity 12.7

### To determine refractive index of water using two pins

#### Materials

- A beaker with water
- 2 search pins
- A clamp and stand
- A ruler

#### Steps

1. Take a beaker containing clean water and measure the **real depth**  $x$  from the base of the beaker to the water surface. Place an object pin O inside the beaker and adjust its position so that the tip of the pin just touches the edge of the beaker.
2. Locate the image of the object pin by keeping the eye vertically above water. Adjust the position of the search pin S by moving it upwards or downwards slowly till its tip and the tip of the image pin as seen through water move together when the eye is moved across the beaker to and fro.
3. Fix the search pin S at this position (Fig. 12.18). Measure the **apparent depth**.

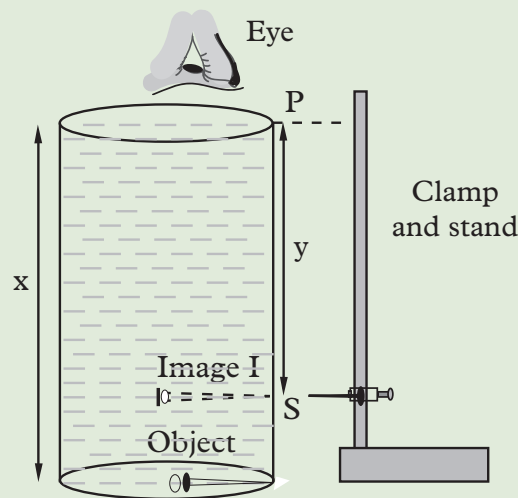


Fig. 12.18: Refractive index of water using two pins

4. Use the values of real and apparent depth to determine the refractive index of water.
5. Present your findings to the class.

**Example 12.6**

The real depth of a pool of water is 6 m and the refractive index of water is 1.33. Calculate the apparent depth of the pool of water.

**Solution**

$$n_{\text{water}} = \frac{\text{real depth}}{\text{apparent depth}}$$

$$\therefore \text{apparent depth} = \frac{\text{real depth}}{n_{\text{water}}} = \frac{6.0}{1.33} = 4.5 \text{ m.}$$

**Example 12.7**

The real thickness of a glass block is 12 cm and apparent thickness is 8 cm. Calculate the refractive index of glass.

**Solution**

$$n_{\text{glass}} = \frac{\text{real depth}}{\text{apparent depth}} = \frac{12}{8} = 1.5$$

**Example 12.8**

The graph in Fig. 12.19 shows the results obtained when a pin was viewed through different sizes of glass of same material.

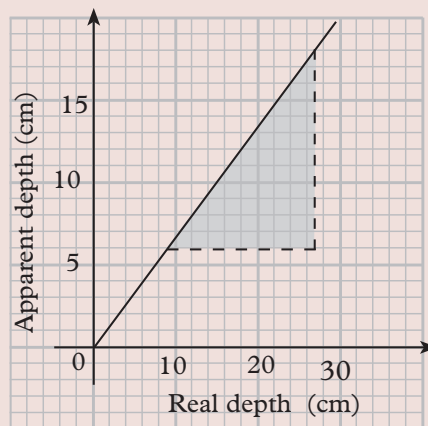


Fig. 12.19: A graph of apparent depth against real depth

Calculate the:

- gradient of the graph.
- refractive index of the glass.

**Solution**

(a) The gradient of the line =  $\frac{\text{apparent depth}}{\text{real depth}} = \frac{18 - 6}{27 - 9} = \frac{2}{3}$

(b) Refractive index,  $n = \frac{\text{real depth}}{\text{apparent depth}}$

$$n = \frac{1}{\text{gradient}} = \frac{1}{\frac{2}{3}} = \frac{3}{2} = 1.5$$

**Exercise 12.3**

1. In Fig. 12.20, the eye can see point P inside an empty cup, but not the coin inside. Suggest a simple method by which the observer can see the coin without moving the position of the eye, the coin or the cup.

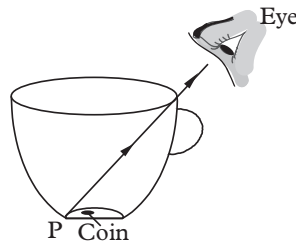


Fig. 12.20: Empty cup

2. The length of a glass block is 6 cm (Fig. 12.21). Using a ray diagram, show how the eye can see the virtual image of object O, if the refractive index of glass is 1.50.

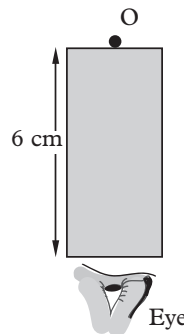


Fig. 12.21: Glass block

3. Describe an experiment to determine the refractive index of a glass block using two pins.
4. In a transparent liquid container, an air bubble appears to be 12 cm when viewed from one side and 18 cm when viewed from the other side (Fig. 12.22). Where exactly is the air bubble, if the length of the tank is 40 cm?

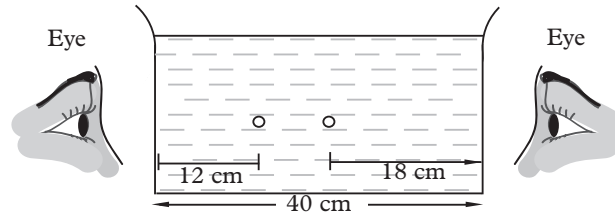


Fig. 12.22: Transparent liquid container

5. The graph in Fig. 12.23 shows the real depth against the apparent depth of a swimming pool as water is being filled.

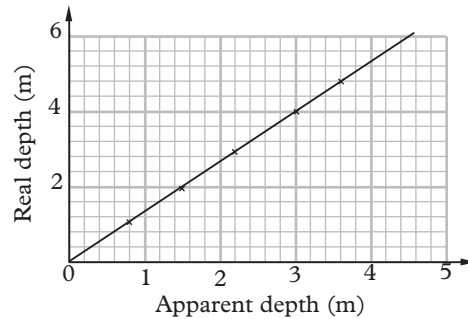


Fig. 12.23: A graph of real depth (m) against apparent depth (m)

- (a) Use the graph to calculate the refractive index of water.  
 (b) Which physical property of light changes as light leaves the pool of water?
6. Describe an experiment to determine the refractive index of water.  
 7. Copy and complete a ray diagram to show how the eye sees the image of the dipped part of the pencil (Fig. 12.24). (Refractive index of water is 1.33).

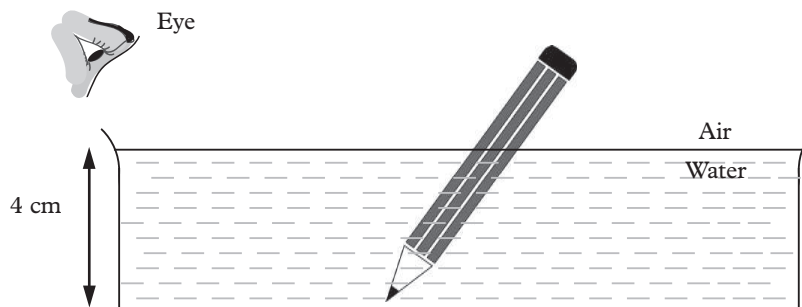


Fig. 12.24: Pencil dipped in water

8. A pool of water seems to be shallower than the real depth whereas the apparent height of a star in the sky is more than the real height. Explain this observation.

### 12.1.7 Critical angle and total internal reflection

For light to refract from a more optical dense to a less optical dense medium, the light ray must be incident at an angle less than a certain angle. The following activity will help us to determine this angle.

#### Activity 12.8

#### To investigate the critical angle and total internal reflection

##### Materials

- Table
- Ray box
- Protractor
- Paper protractor
- Semi circular glass block

##### Steps

1. Fix a thin circular 'paper protractor' calibrated in degrees on the table top.
2. Place a semicircular glass block such that the edge AB coincides with the  $90^\circ$ – $90^\circ$  mark of the protractor ensure the midpoint of the line AB is at Q (Fig. 12.25 (a)). The line along  $0^\circ$ – $0^\circ$  mark represents the normal NQM at Q.
3. In a dark room, use a ray box to pass a ray of light through the glass block at an angle of incidence ( $i$ ) say  $20^\circ$  (Fig. 12.25 (a)). Observe the path of the ray CQ in glass and ray QR in air, for the incident ray PC.

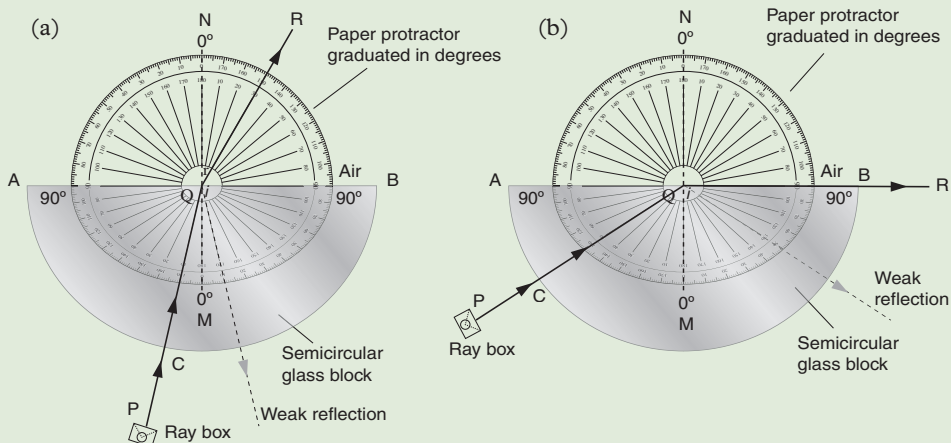


Fig. 12.25: Critical angle.

4. Increase the angle of incidence,  $i$ , gradually and observe the relative change in the path of the refracted ray in air. Explain your observation.

At C the ray strikes the glass block at an angle of  $90^\circ$  and is therefore not deviated inside the glass along QC. At Q, the refracted ray in air moves away from the normal and the angle of refraction,  $r$ , in air is greater than the angle of incidence,  $i$ , inside the glass.

As the angle of incidence increases, the ray is refracted further away from the normal until, at one angle, it falls along the edge AB of the semicircular glass block. At this angle, the refracted ray cannot be located on the air. This particular angle of incidence is called *critical angle*,  $c$ , (Fig. 12.25 (b)).

The critical angle *is the angle of incidence in a denser medium for which the angle of refraction is  $90^\circ$  in the rarer medium.*

When the angle of incidence is greater than the critical angle, there is no refraction and all the light is reflected back inside the denser medium. This phenomenon is known as *total internal reflection* (Fig. 12.26). The angle of reflection,  $r$ , is equal to the angle of incidence,  $i$ .

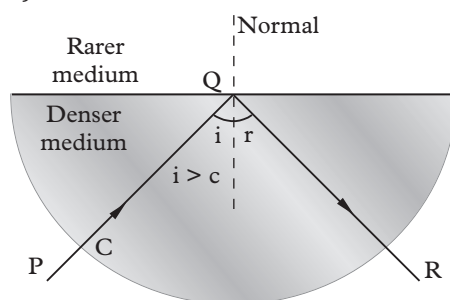


Fig. 12.26: Total internal reflection

The following conditions must be satisfied for total internal reflection to occur:

1. Light must travel from a denser medium to a rarer medium.
2. The angle of incidence in the denser medium must be greater than the critical angle.

### Refractive index using critical angle

Using Snell's law, the refractive index of glass-air boundary

$${}_g n_a = \frac{\sin i}{\sin r}$$

But if  $i = c$ ,  $r = 90^\circ$  and principle of reversibility (see Fig. 12.25(b)).

$$\therefore {}_a n_g = \frac{\sin 90^\circ}{\sin c} = \frac{1}{\sin c}$$

Hence, refractive index of a medium  ${}_a n_g = \frac{1}{\sin c}$  where  $c$  is the critical angle.

### Example 12.9

Calculate the critical angle for glass-air interface, if the refractive index of glass is 1.50.

**Solution**

$$\eta_{\text{glass}} = \frac{1}{\sin c}$$

$$\sin c = \frac{1}{\eta_g} = \frac{1}{1.50} = 0.667$$

$$c = \sin^{-1} 0.667 = 41.8^\circ$$

**Example 12.10**

Calculate the critical angle at the water-air interface if the refractive index of water is 1.33

**Solution**

$$\eta_w = \frac{1}{\sin c}$$

$$\sin c = \frac{1}{\eta_w} = \frac{1}{1.33} = 0.752$$

$$c = \sin^{-1} 0.667 = 48.8^\circ$$

**Example 12.11**

Calculate the refractive index of diamond, if the critical angle for the diamond is  $24^\circ$ .

**Solution**

$$\eta_d = \frac{1}{\sin c} = \frac{1}{\sin 24^\circ} = \frac{1}{0.407} = 2.46$$

$\therefore$  Refractive index of diamond is 2.46

**12.2 Refraction of light through a prism****12.2.1 Demonstration of refraction of light through a prism****Activity 12.9**

To show refraction of light through a prism

**Materials**

- A glass prism
- White plain paper

**Steps**

1. Place a glass prism on a white paper as shown.

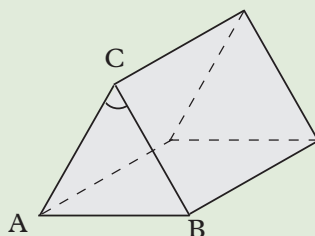


Fig. 12.27

2. Incident a ray of light on the edge CA.
3. What happens to the ray of light as it enters and leaves the glass prism?
4. Compare its behaviour between when it enters and leaves a rectangular glass block.

In real glass block the 1<sup>st</sup> refraction cancels the 2<sup>nd</sup> refraction. Hence, the incident ray and emergent ray are parallel. In the case of a glass prism, the 2<sup>nd</sup> refraction adds to the 1<sup>st</sup> refraction. This is the importance of a prism. It can be used to analyse the components of white light.

A prism has a refracting medium bound by two plane surfaces inclined to each other at an angle. The two planes are the *refracting faces* ( $ADEC$  and  $ADFB$  in Fig. 12.28 (a)) and the angle between the faces is called the *angle of the prism* ( $\angle CAB$  in Fig. 2.28 (a)). The line along which the two faces meet is the *refracting edge* of the prism. The face opposite to the angle of the prism is called the *base of the prism* (Fig. 12.28 (a)). The section of the prism cut by a plane perpendicular to the edge of the prism is the *principal section* of the prism Fig. 12.28 (b) )

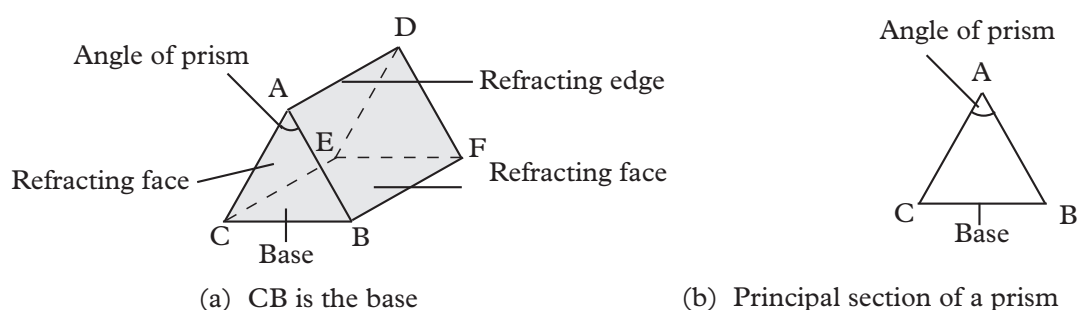


Fig. 12.28: Glass prism

When light passes from air into the triangular glass prism (ray PQ), it undergoes refraction. The refracted ray QR inside the glass bends towards the normal  $N_1N_2$ . The emergent ray RS bends away from the normal  $N_3N_4$  (Fig. 12.29). Ray PQ produced meets ray RS produced backwards at T. Notice that, the incident ray has *deviated* from its original direction. Angle VTR is called the *angle of deviation*. Hence the action of a prism is to *deviate light rays*.



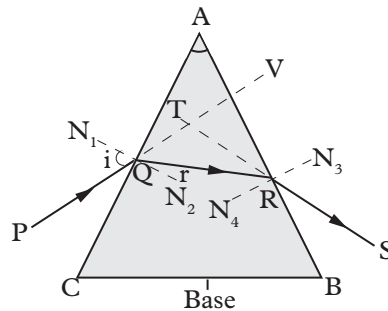


Fig. 12.29: Refraction of light through a prism

### 12.2.2 Dispersion of white light by a prism

#### Activity 12.10

#### To illustrate dispersion of white light

##### Materials

- Triangular prism
- White screen
- Ray of white light

##### Steps

1. A narrow beam of white light (such as sunlight, light from carbon arc lamp or a mercury vapour lamp) from a narrow slit, in a semi-dark room, to an equilateral glass prism.
2. Adjust the angle of incidence until a distinct band of colours is obtained on a white screen placed on the other side of the prism as shown in Fig. 12.30.

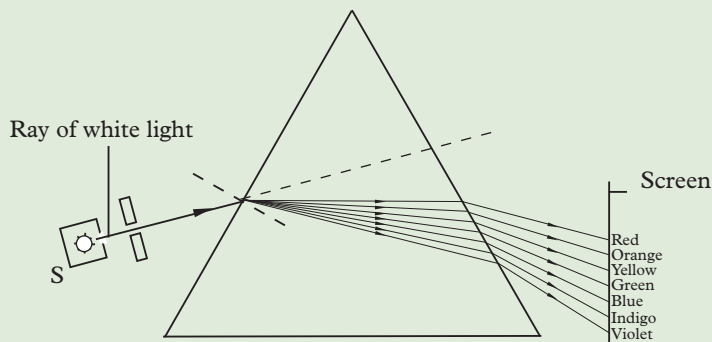


Fig. 12.30: Dispersion of white light forming a spectrum of colours

3. What colours are obtained on the white screen? How many of the colours can you identify? Is the angle of deviation the same for each colour?

A *monochromatic light* is one that has a *single colour* and a *single frequency* or *single wavelength*. White light is not monochromatic because it is made up of seven different colours. Non-monochromatic light is also called *composite light*.

When white light is passed through a triangular prism, it is split up into a series of colours as it enters the glass prism. Different colours are deviated to different angles. The colours are *red, orange, yellow, green, blue, indigo and violet*. These colours gradually blend into one another.

The above experiment was first carried out by Sir Isaac Newton. He noticed that *violet light is the most deviated colour* while *red light is the least deviated colour*. The splitting of white light into its constituent colours is called *dispersion*. The coloured band produced is called *visible spectrum* (Fig. 12.30).

For the same angle of incidence, each colour inside the glass prism has its own angle of refraction and angle of deviation. Since refractive index is given by  $n = \frac{\sin i}{\sin r}$ , it follows that each colour has its own refractive index for glass. But refractive index is also given by  $n = \frac{\text{speed of light in air}}{\text{speed of light in glass}}$ .

Therefore each colour travels with its own speed inside glass. For example, violet light having the least angle of refraction has the greatest refractive index for glass. This means that the speed of violet light is the least in glass.

If two identical prisms are placed as shown in the Fig. 12.31, the final spectrum produced is more spread out. This means that the angle of deviation of each colour is increased.

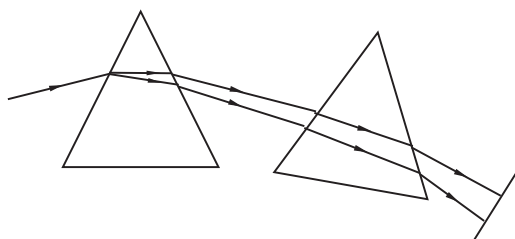


Fig. 12.31: More spread out spectrum.

### 12.2.3 Combination of spectrum colours

The dispersion created by one prism can be *reversed* by a second prism (Fig. 12.32). When reversed, a white light parallel to the incident white light emerges from the second prism.

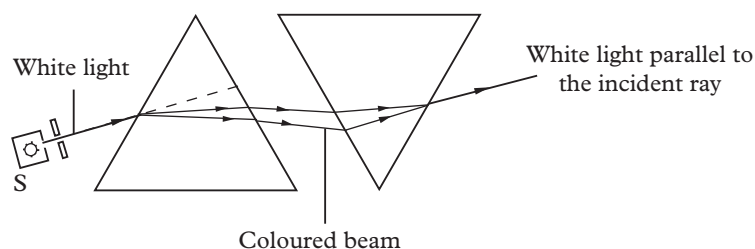


Fig. 12.32: Separation and combination of colours by prisms

## Exercise 12.4

- Define critical angle.
  - Write down the relationship between the critical angle and the refractive index of a medium.
- State the two conditions under which total internal reflection occurs.
- Calculate the value of critical angle for a liquid-air interface, if the refractive index of the liquid is 1.40.
- Copy and complete Fig. 12.33 to show the path of a ray of light through the glass prism. Mark the angle of incidence and the angle of deviation in your diagram
- Distinguish between monochromatic and composite light. Give an example of each.
- What do you understand by the terms deviation and dispersion.
- Write down the colours in a visible spectrum in the decreasing order of angle of deviation.
- Fig. 12.34 shows the path of a ray of white light incident on a glass prism.
  - What name is given to the spreading out of white light inside the prism?
  - What name is given to the band of colours seen on the screen?
  - Name two physical properties which change for all the colours when they enter the prism.
  - Mark the position of violet, blue and red light as seen on the screen.
- Describe an experiment to illustrate the dispersion of white light.
- A beam of light made of a mixture of red and green light is shone through a prism (Fig. 12.35).

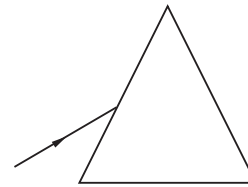


Fig. 12.33: Separation and combination of colours by prisms

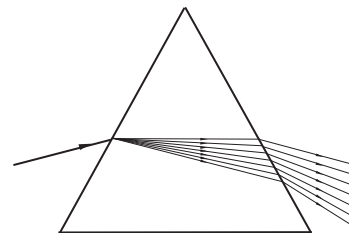


Fig. 12.34

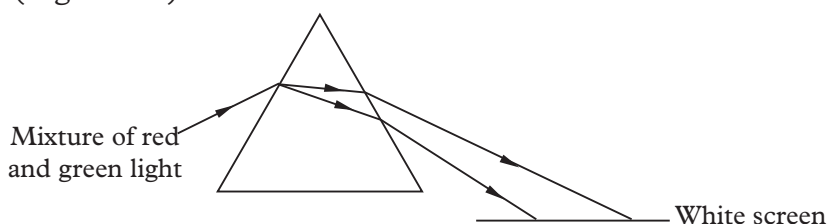


Fig. 12.35

- (a) What name is given to the ‘bending’ of light as it enters the glass prism?
- (b) Why does light ‘bend’ as it enters glass prism?
- (c) Why do the two colours of light bend by different amount inside the prism?
- (d) Which colour ‘bends’ the least?

### 12.2.4 Total internal reflection of light by a prism

Under certain circumstance total internal reflection can occur in a prism. The following activity will demonstrate this.

#### Activity 12.11

#### To show total internal reflection by a prism

##### Materials

- Right-angled prism, white plain paper
- Mathematical set

##### Steps

1. Place a right-angled prism on a white paper.
2. Direct a ray (ray 1) towards side AB at a large angle of incident say  $60^\circ$ . Trace the outline of the prism and record the angle of incidence on the side AB.
3. Repeat with (ray 2) less than  $60^\circ$  this time say  $40^\circ$ .
4. Continue decreasing the angle until the angle of incidence is zero (ray 3). What happens to the angle of incidence on AB?

The angle is seen to increase up to the critical angles of glass (i.e.  $42^\circ$ ). Refraction stops and reflection occurs. (See Fig. 12.36)

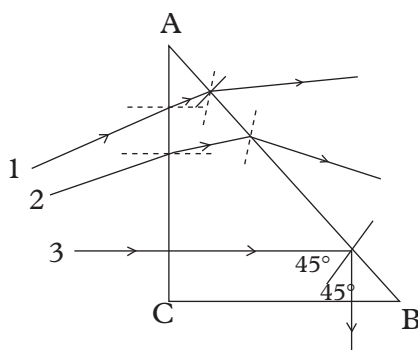


Fig. 12.36:

For ray 3, the angle of incidence ( $45^\circ$ ) on the side AB is greater than the critical angle hence total internal reflection occurs and the ray emerges perpendicular to the other smaller side CB.

### Example 12.12

Copy and complete Fig. 12.37 to show the path of light PQ as it enters the right angled isosceles prism of refractive index 1.50.

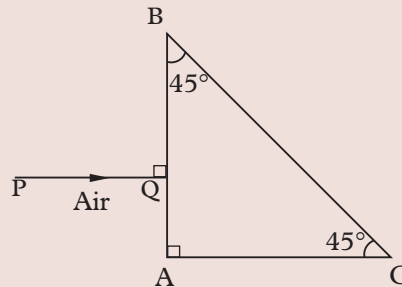


Fig. 12.37: Isosceles prism

### Solution

Critical angle  $c$  for glass-air interface is given by

Critical angle  $c$  for glass-air interface.

$$\sin c = \frac{1}{n_{\text{glass}}} = \frac{1}{1.5} = 0.667$$

$$c = 41.8^\circ$$

At the surface AB, the ray passes undeviated

along QR in glass. At the surface BC,

the angle of incidence,  $i = 45^\circ$ ,

since  $\angle BRQ = \angle BCA = 45^\circ$

(corresponding angles),  $r = 90^\circ - 45^\circ = 45^\circ$ .

Since  $i$  is greater than the critical angle  $c$ ,

total internal reflection occurs (ray RS).

Ray RS proceeds undeviated as ST in air

(Fig. 12.38).

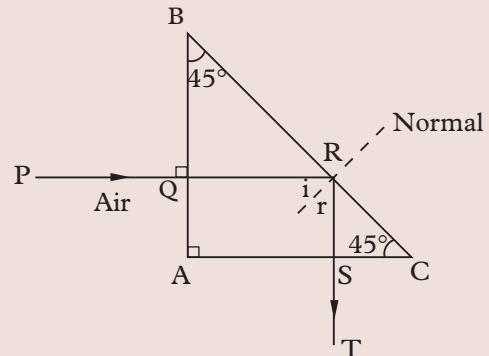


Fig. 12.38: Total internal reflection in isosceles prism

### Example 12.13

A ray of light passes from a liquid to air. Calculate the critical angle for the liquid-air interface, if the velocity of light in the liquid is  $2.4 \times 10^8$  m/s, while in air is  $3.0 \times 10^8$  m/s.

**Solution**

$$\text{Refractive index of a liquid} = \frac{\text{velocity of light in air}}{\text{velocity of light in liquid}}$$

$$= \frac{3 \times 10^8}{2.4 \times 10^8} = 1.25$$

$$\eta_{\text{medium}} = \frac{1}{\sin c} \quad \sin c = \frac{1}{\eta_{\text{medium}}} = \frac{1}{1.25} = 0.80$$

$$c = 53.1^\circ$$

The critical angle for the liquid is  $53.1^\circ$ .

**12.2.5 Application of total internal reflection of light****Activity 12.12**

To describe the application of total internal reflection of light by a prism

**Materials**

- Right-angled prism
- white plain paper
- Mathematical set
- Blue coloured plate (filter)

**Steps**

1. Incident two rays of red light as shown in Fig 12.39(a). The two rays emerge on side CD.

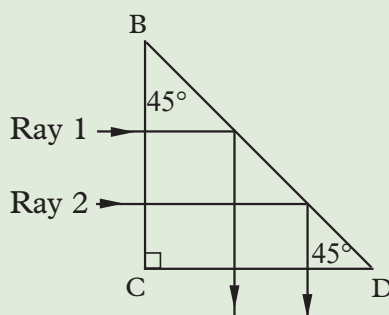


Fig. 12.39 (a)

2. Hold a blue glass plate (filter) in front of ray 2. The ray 1 is coloured blue (see Fig. 12.39(b)).
3. Turn the prism as shown in Fig 12.39(b) The blue ray enters as upper ray, but emerges on lower ray.

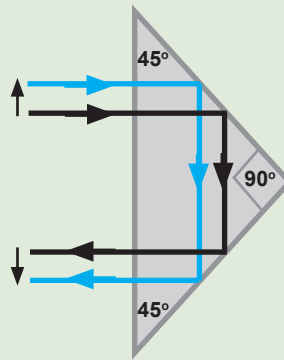


Fig. 12.39 (b)

This shows that a right-angled prism can therefore be used to reverse an image laterally. The following are some of the applications of total internal reflection of light in prism.

### 1. Totally reflecting prism

Right angled isosceles prisms deviate light rays through an angle of  $90^\circ$  (Fig. 12.40).

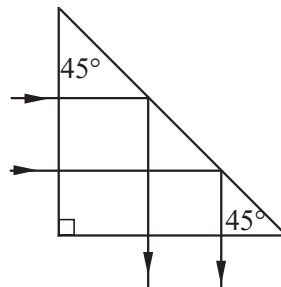


Fig. 12.40: Action of isosceles prisms

Reflecting prisms have more advantages than plane mirrors. Since plane mirrors are silvered at the back surface of a thick glass plate, they give rise to a number of *faint* images besides the *main* image. They also lose light intensity due to the refraction in glass. In the case of reflecting prisms, the light is totally reflected without much loss of intensity. They do not have invisible faint images found in mirrors. The silvering of the mirror may wear off with time whereas a prism has a tough structure. Due to these advantages, reflecting prisms are preferred in optical instrument such as periscopes, binoculars and camera.

### 2. Prism periscope

A periscope is a device which enables us to see over the top of an obstacle. Two right angled isosceles prism are used in *prism periscope* instead of the two plane mirrors used in a *simple periscope*. This periscope produces brighter images than

those formed by plane mirrors.

A parallel beam of light normally incident on the first prism is turned through  $90^\circ$  and proceeds to the second prism and is again turned through  $90^\circ$  to reach the eye of a person. The final image produced is virtual and upright (Fig. 12.41).

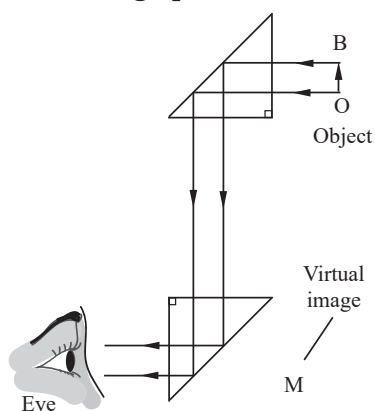


Fig. 12.41: Action of a prism periscope

The periscope of this type is normally used in submarines to sight enemy ships over the surface of the sea.

### 3. Optical fibres

An optical fibre is a long clear glass rod which can be of thickness of a fraction of a millimeter. When a ray of light enters the fibre, the angle of incidence,  $i$ , inside the glass is always greater than the critical angle  $c$  for glass-air interface and hence undergoes total internal reflection repeatedly on the boundary of glass fibre and air (Fig. 12.42). Light travels along the length of an optical fibre without much loss of light intensity.

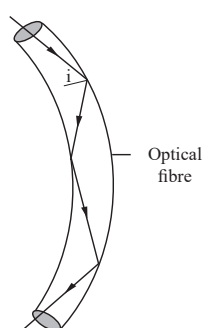


Fig. 12.42: Passage of light through an optical fibre

Optical fibres are used in transmitting signals in communication. In medicine, bundles of very fine flexible fibres are used to view the internal parts of a human body using an instrument called the *endoscope*.



#### 4. Rainbow

White light from the sun undergoes dispersion as it enters into the raindrops of water in the sky. Total internal reflection takes place at the opposite side of the raindrop and different colours emerge from the raindrop after refraction (Fig. 12.43).

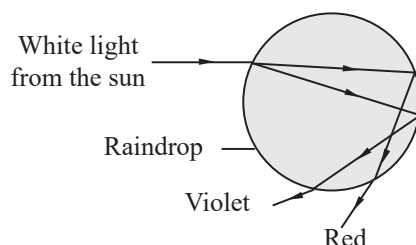


Fig. 12.43: A single raindrop produces a spectrum

#### 5. Mirage

The mirage is an *optical illusion* that takes place in a hot desert or a hot road due to total internal reflection. A traveller sees in the distance a *shimmering pool of water* in which the surrounding objects, like a tree, appear inverted (Fig. 12.44).

Light travelling from a denser medium (warm air) towards the earth, enters regions of rarer medium (very hot air of low density in contact with the earth) and undergoes total internal reflection at a certain point when the angle of incidence is greater than the critical angle. An observer on a distance sees the inverted image of the tree. Further, as hot air in contact with the earth rises up due to convection currents, the image appears shimmering.

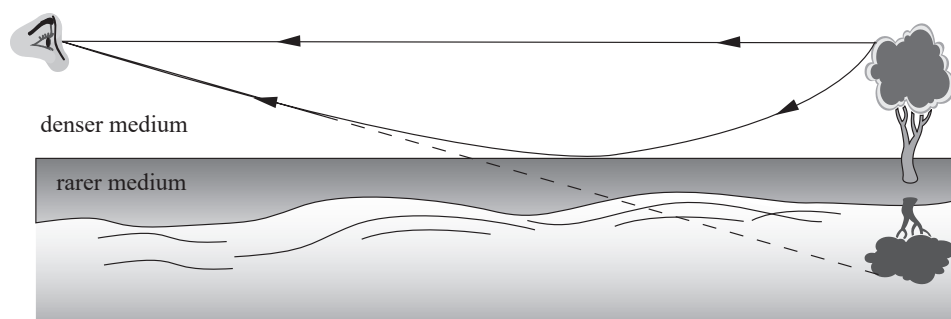


Fig. 12.44: Mirage

#### Exercise 12.5

1. Certain prism may be used in such a way that refraction takes place when light passes through it. Draw a diagram of a prism acting in this way and deviating a ray of light through  $90^\circ$ .

2. A ray of light strikes a prism as shown in Fig. 12.45. Copy and complete the diagram to show the path followed by the ray as it passes through and out of the prism.

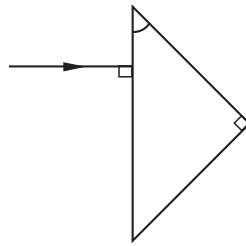


Fig. 12.45: Triangular prism

3. (a) Draw a diagram to show how two right angled isosceles prisms can be used in a periscope.  
 (b) State a reason why glass prisms are preferred to plane mirrors for use in periscopes.
4. The critical angle for a glass-air interface is  $42^\circ$ . Copy and complete Fig. 12.46 to show the path of PQ and RQ, when they leave the glass block.

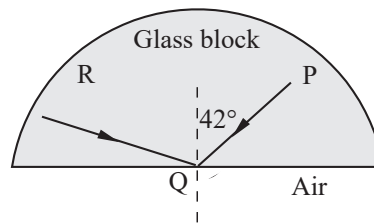


Fig. 12.46: Glass block

5. A narrow beam of light is incident on the face PQ of a glass prism of refractive index 1.50, as shown in Fig. 12.47.

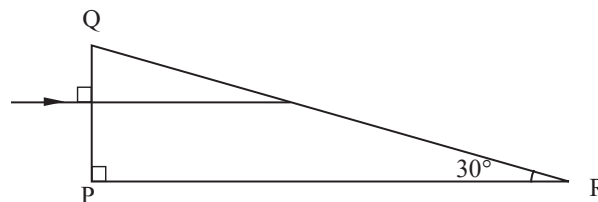


Fig. 12.47: Glass prism

- (a) What is the angle of incidence at the face QR of the prism?  
 (b) Copy and complete the diagram to show the path of light.  
 (c) Why does the beam not change direction as it passes through the face PQ?  
 (d) Give one change in property that occurs to the light when it passes through the face PQ.

6. Fig. 12.48 shows the path of a ray of light passing through a length of an optical fibre. Explain why the ray of light (a) does not change direction at B or at E (b) is totally reflected at C and D.

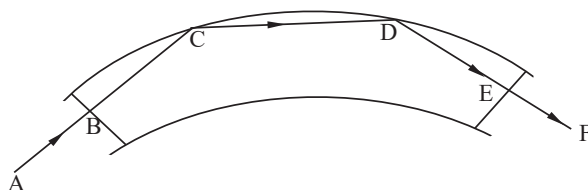


Fig. 12.48: Optical fibre

## 12.3 Refraction of light through a thin lens

### 12.3.1 Definition of a lens

#### Activity 12.13

#### To find out what a lens is

##### Materials:

- Water
- Round bottom flask
- Plain paper
- Retort stand
- Sun

##### Steps

1. Fill a volumetric flask with clear water.
2. Cork the flask.
3. Tilt the flask such that the neck of the cork is horizontal.
4. Place a source of light (sun, bulbs) above the flask.
5. Place a white paper under the flask preferably on the ground.
6. Move the flask to or away the white paper.
7. What happens on the plain paper?
8. Record and discuss the results.

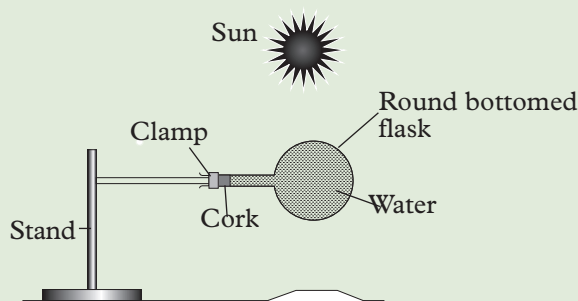


Fig. 12.49

A lens is a transparent medium bounded by two spherical surface or a planed curved surface.

### 12.3.2 Types of lenses

#### Activity 12.14

#### To describe types and shapes of lenses

##### Materials:

- Charts showing converging and diverging beam through lens.
- Plane lenses.
- Convex lenses
- Spherical lenses

##### Steps

1. Place some lenses available in your school on a labeled white plane paper. Trace their outlines. Describe the shapes of the lenses?
2. Identify the lenses in Fig.12.5 b by name.

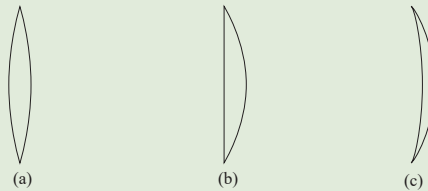


Fig. 12.50

3. Identify the lenses in Fig. 12.51

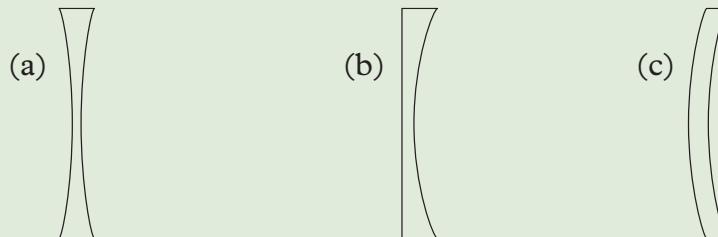


Fig. 12.51

There are two main groups of lenses. A type that is thick in the middle and thin at the edges, causing rays of light to converge. This is called **converging** or **convex lenses**. The other type is thin in middle and thick at the edges causing the rays of light to diverge. This lens is called **diverging** or **concave lens**.

Concave lenses are of different shapes as shown in Fig. 12.52

A *bi-convex* or *double convex* lens has both its surfaces ‘curving out’. (Fig. 12.52).

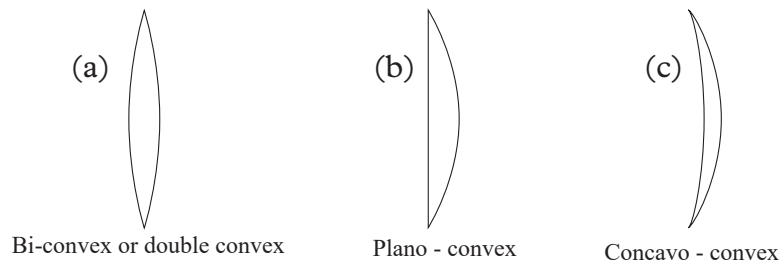


Fig. 12.52: Types of convex lenses

Concave lenses are also of different shapes (See Fig. 12.53)

A *bi-concave* or *double concave* lens has both its surfaces ‘curving in’. Other concave lenses are *plano-concave* and *convexo-concave* or diverging meniscus (Fig. 12.50).

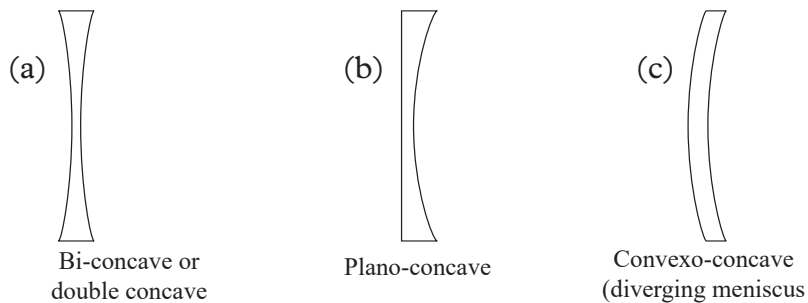


Fig. 12.53: Types of concave lenses

### 12.3.3 Terms used in thin lenses

#### Activity 12.15

#### To find out the terms used in thin lenses

#### Materials

- Double convex lenses
- Sunshine
- Piece of paper

#### Steps

1. Take a double convex lens outside on a very sunny day.
2. Place a dry tissue paper (or leaves) on a flat open ground.
3. Place the lens on the tissue paper.
4. Slowly lift lens vertically away from the paper until a spot of light is formed on the paper.
5. Hold the lens at this position for some time.
6. Observe what happens to the paper. Explain
7. Repeat the activity with a concave lens. What do you observe? What happens to the beam of light?

The paper starts to burn. This shows that a convex lens brings to a focus point light energy from the sun and since light is in form of energy, a lot of it is concentrated at a point. This point where the rays are brought together after passing through the convex lens is called **principal focus**. This point is **real**.

When the activity was repeated with a concave lens, nothing happens. The principle focus of a concave lens is virtual.

The following are other common terms used in thin lenses:

### (a) The centre of curvature (C)

The centre of curvature of the surface of a lens is the *centre of the sphere* of which the surface forms a part (Fig. 12.54 (a) and (b)). For each spherical lens there are two centres of curvature ( $C_1$ ,  $C_2$ ) due to the two curved surface.

### (b) The radius of curvature (r)

The radius of curvature of the surface of a lens is the *radius of the sphere* of which the surface forms a part (Fig. 12.54 (a) and (b)). Each surface has its own radius of curvature ( $r_1$  or  $r_2$ ).

### (c) Principal axis

The principle axis of a lens is a line passing through the two centres of curvature ( $c_1$  and  $c_2$ ) as shown in Fig. 12.54.

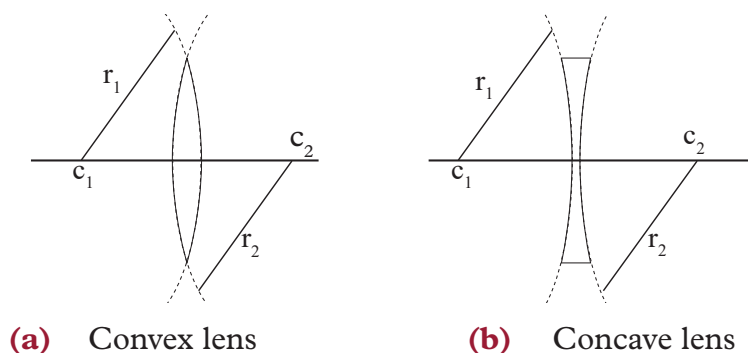


Fig. 12.54: Principal axis

### (d) The principal focus

A prism always deviates the light passing through it towards its base. A convex lens may be regarded as being made up of large portions of triangular prisms as shown below. The emergent beam, therefore, becomes convergent in a convex lens (Fig. 12.55 (a)). The reverse is the effect in a concave lens (Fig. 12.55(b)).

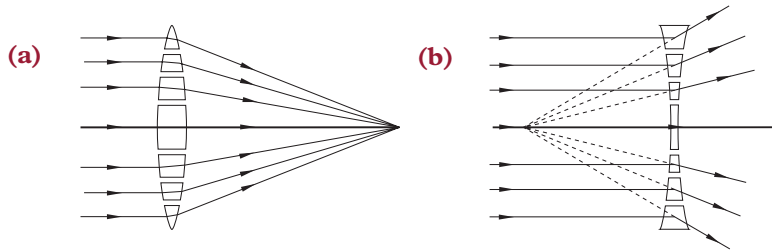


Fig. 12.55: Action of lenses on incident rays of light.

### (i) Principal focus of a convex lens

Consider a set of incident rays parallel and close to the principal axis of a convex lens (Fig. 12.56). These rays, after refraction through the lens, pass through point  $F$  on the principal axis. Since all the rays converge at this point, it is called *principal focus*. Since this point can be projected on a screen, it is said to be a *real principal focus*.

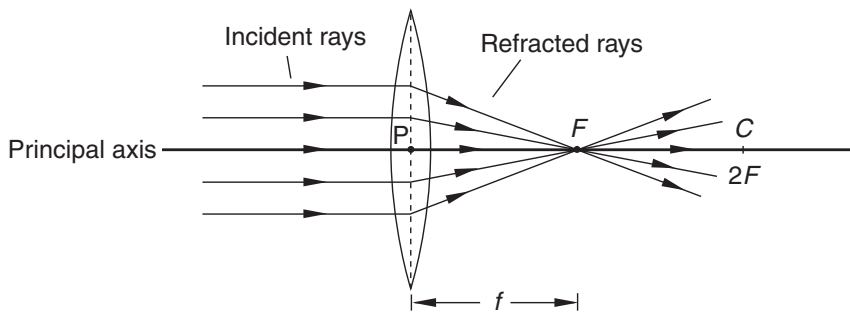


Fig. 12.56: Principal focus on a convex lens

### (ii) Principal focus of a concave lens

For a set of incident rays parallel and close to the principal axis of a concave lens, the refracted rays appear to diverge from a fixed point on the principal axis. This point is called the *principal focus*  $F$ , of a concave lens (Fig. 12.57). This principal focus is virtual since it cannot be projected on a screen.

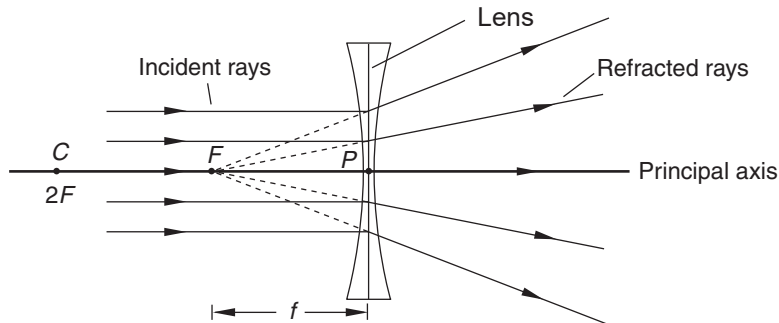


Fig. 12.57: Principal focus on a concave lens

**(e) The focal plane**

When a set of parallel rays are incident on a convex lens at an angle to the principal axis, as shown in Fig. 12.58, the refracted rays converge to a point, on a line passing through  $F$  and perpendicular to the principal axis. The plane passing through  $F$  is the *focal plane*.

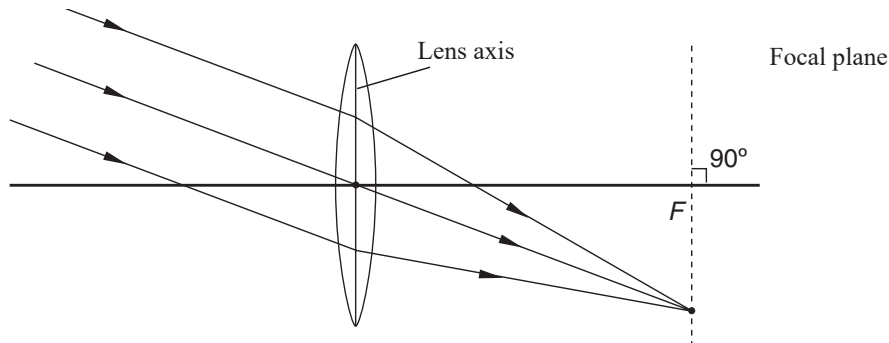


Fig. 12.58: Focal plane of a convex lens

**(f) The optical centre (P)**

The *optical centre* of a lens is a point which lies exactly in the middle of the lens ( $PA = PB$ ) as shown in Fig. 12.59(a) and 12.59(b). Light rays going through this point go straight through without any deviation or displacement.

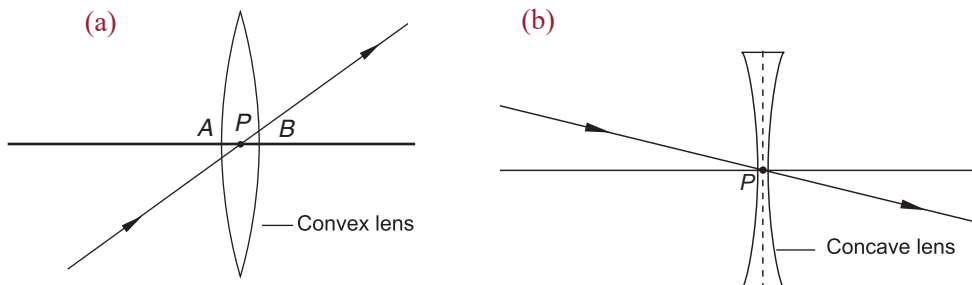


Fig. 12.59: Optical centre of a convex and concave lenses

**(g) The focal length of a lens (f)**

This is the distance from the optical centre to the principal focus of the lens (see Fig. 12.51(a) and 12.51(b)). Biconvex and biconcave lenses have a focal length on each side of the lens.

The concept of centres of curvature of the surfaces is required only in drawing the principal axis. Otherwise these points are referred to as  $2F$ , as they are situated at a distance twice the focal length from the centre of the lens ( $PC = 2PF$ ).



### Exercise 12.6

1. Distinguish between converging and diverging lenses.
2. Define the following:
  - (a) Principal axis
  - (b) Optical centre
3. Differentiate between the principal focus of the concave and convex lens.
4. How many principal foci does a biconcave lens have?

#### 12.3.4 Image formation by converging lenses

#### Activity 12.16

To analyse the image formed by converging lenses

#### Materials

- Convex lenses
- Tree, Screen (white wall can act as screen)

#### Steps

1. Place a convex lens between a wall of a lab and a far away object e.g. a tree outside the lab. (See fig 12.60)

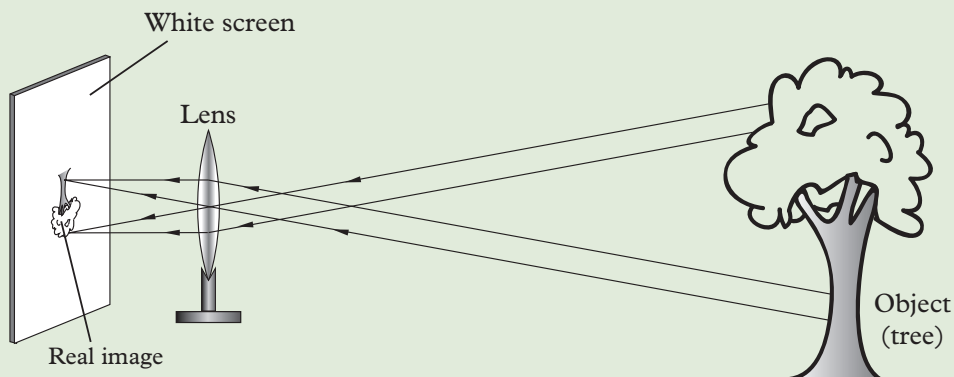


Fig. 12.60: Object at infinity

2. Adjust the distance between the lens and the wall until the image of the tree is observed on the wall.
3. What are the characteristics of the image formed?
4. In groups, discuss how you can explain the formation of such an image using ray diagrams.

Ray diagrams are used to illustrate how and where the image is formed. The following are the important incident rays and their corresponding refracted rays used in the construction of ray diagrams.

**Ray 1:** A ray of light parallel and close to the principal axis, passes through the principal focus  $F$  (Fig. 12.61).

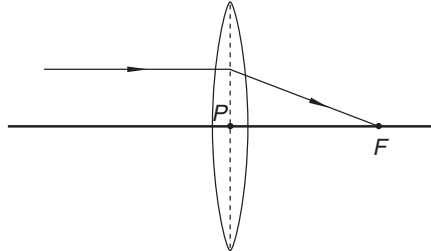


Fig. 12.61: Ray 1

**Ray 2:** A ray of light through the principal focus  $F$  emerges parallel to the principal axis after refraction (Fig. 12.62).

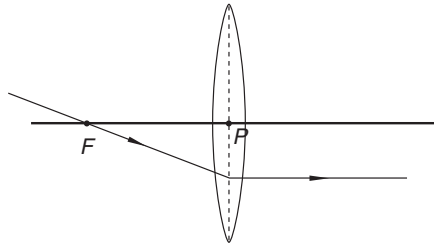


Fig. 12.62: Ray 2

**Ray 3:** A ray through the optical centre,  $P$  is undeviated after refraction through the lens (Fig. 12.63).

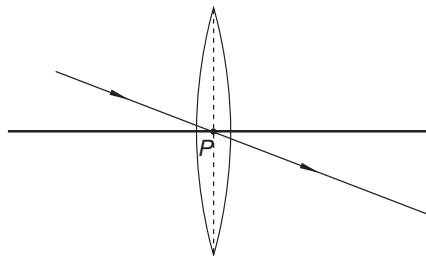


Fig. 12.63: Ray 3

### 12.3.5 Locating images by simple ray diagrams and describing their character

To locate the image of an object, we need a minimum of two incident rays from the object. From the three standard rays discussed above, any two incident rays and their corresponding refracted rays can be drawn to locate the image. If the refracted rays converge, a *real image* is obtained. If the refracted rays diverge, then a virtual image is obtained.

### 12.3.5.1 Convex lens

#### Activity 12.17

To describe the characteristics of images formed by convex lenses when the object is at infinity

#### Materials

- White screen
- Tree
- Lens
- Metre rule

#### Steps

1. Position a convex lens vertically in front of a tree far away from the lens (through a window).
2. Place a white screen on the other side of the lens as shown in Fig. 12.64. Adjust the screen until you see a sharp image of the tree.
3. Compare the size of the image with that of the object (tree). Is the image bigger or smaller? Is it upright or inverted?
4. Measure the distance from the lens to the screen. What does this distance represent in this set up?

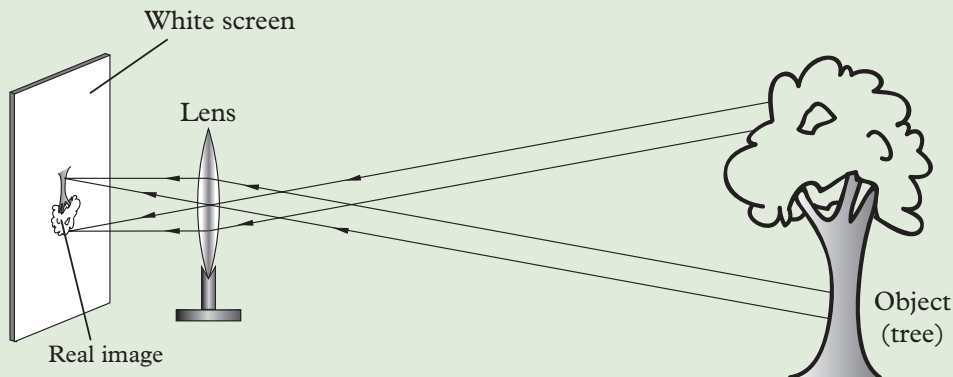


Fig. 12.64: Object at infinity



**Note:** The distance from the centre of the lens to the screen is nearly equal to the focal length,  $f$ , of the lens.

#### (a) Object far away from the lens (at infinity)

Since the object is at infinity, all the rays from the object, incident on the lens are almost parallel. The refracted rays converge at a point on the focal plane, as shown in Fig. 12.65.

**Image characteristics**

A *diminished, real, inverted* image is formed at  $F$ .

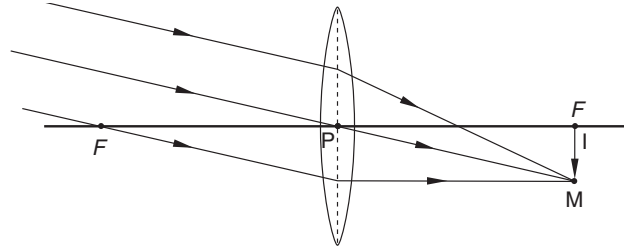


Fig. 12.65: Object  $OB$  at infinity

**(b) Object  $OB$  just beyond  $C$  ( $2F$ )****Activity 12.18**

To describe images formed by convex lens when the object is beyond  $2F$  and at  $2F$

**Materials**

- Screen
- Lens
- Candle

**Steps**

1. Mark the positions of the principal focus  $F$  and  $2F$  on both the sides of the lens with a piece of chalk.
2. Place a lit candle on the table along the principal axis of the lens, slightly away from  $2F$ .
3. Place a white screen, on the other side of the lens, perpendicular to the principal axis of the lens and adjust its position to and fro to the screen and observe what happens. What are the characteristics of the image formed?

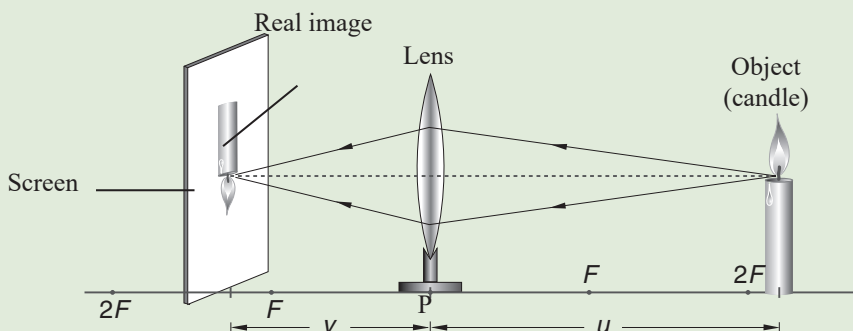


Fig. 12.66: Object beyond  $2F$

4. Repeat step 3 by placing the candle at  $2F$  and observe what happens. What are the characteristics of the images formed?

Fig 12.67 shows the ray diagram to locate the images when the object is beyond C.

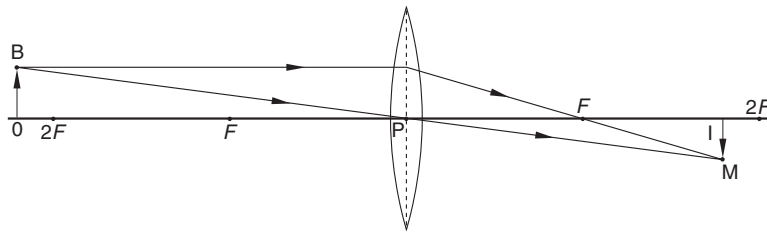


Fig. 12.67: Object  $OB$  just beyond  $2F$

### Image characteristics

A *diminished, real, inverted* image is formed between  $F$  and  $2F$ .

### (c) Object $OB$ at $2F$

The ray diagram when the object (candle) was placed at  $2F$  is as shown in Fig. 12.68

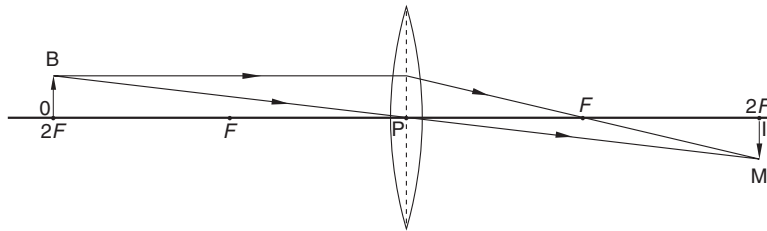


Fig. 12.68: Object  $OB$  at  $2F$

### Image characteristics

A *real, inverted* image of the *same size* as the object is formed at  $2F$

### (d) Object $OB$ between $2F$ and $F$

## Activity 12.19

To describe the images formed by convex lens when the object is between  $F$  and  $2F$  and at  $F$

### Materials

- Candle
- Lens
- Screen

### Steps

1. Repeat activity 12.16 by placing the candle between  $2F$  and  $F$ .
2. What can you say about the characteristics of the image formed on the screen (Fig. 12.69)?

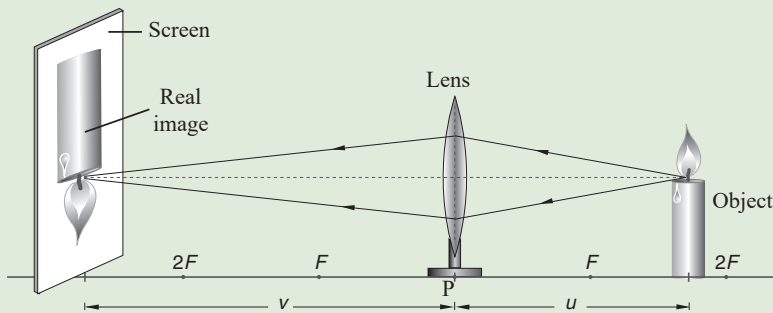


Fig. 12.69: Object between  $2F$  and  $F$

3. Now move the candle to point  $F$ . What do you observe? describe the characteristics of the image formed.

The simple ray diagram when the object is between  $F$  and  $2F$  is as shown in Fig. 12.70.

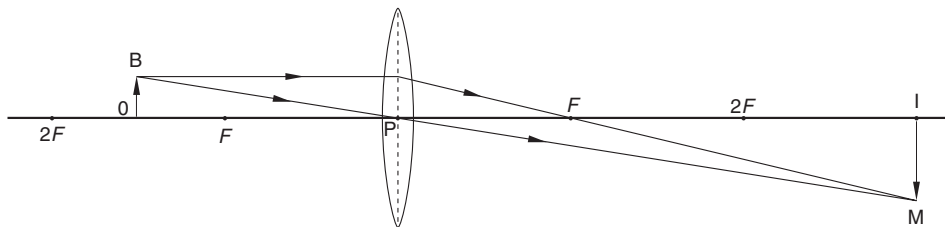


Fig. 12.70: Object  $OB$  between  $2F$  and  $F$

### Image characteristics

A *real, inverted* and *magnified* image is formed beyond  $2F$

### (e) Object $OB$ at $F$

When the object was at  $F$ , the refracted rays are nearly parallel and converge at infinity as shown in Fig. 12.71.

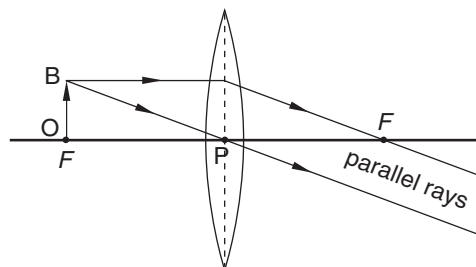


Fig. 12.71: Object  $OB$  at  $F$

### Image characteristics

A *real, inverted, magnified* image is formed far away from the lens i.e. at infinity. (cannot be described)

**(f) Object OB between F and P****Activity 12.20**

**To describe the image formed by convex lens when the object is between F and P**

**Materials**

- Candle
- Lens
- Screen

**Steps**

Repeat activity 12.66 keeping the candle close to the lens, between  $F$  and  $P$ . Can you get an image on the screen? Describe its characteristics.

The image formed is virtual and cannot be projected on the screen. An enlarged, upright image can be seen through the lens on the same side with the object (Fig. 12.72).

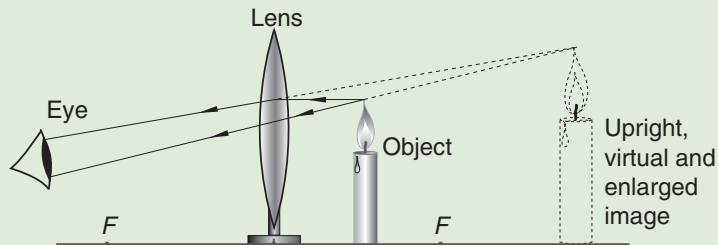


Fig. 12.72: Object between  $F$  and  $P$

A simple ray diagram to locate image when the object is placed between  $F$  and  $P$  is as shown in Fig. 12.73.

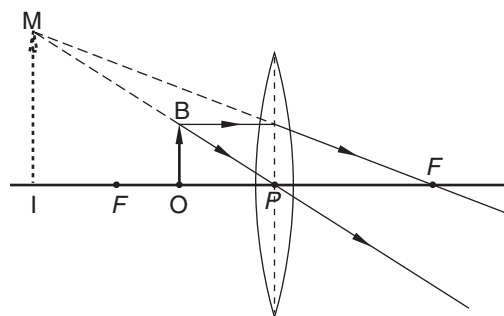


Fig. 12.73: Object  $OB$  between  $F$  and the lens.

**Image characteristics**

A magnified, upright and virtual image is formed on the same side as object.

### 12.3.5.2 Concave lens

When the object is at infinity, an upright, diminished and virtual image is formed at principal focus  $F$ . For all other positions of the object  $OB$ , an upright, diminished, virtual image is always formed between  $F$  and  $P$  (Fig. 12.74).

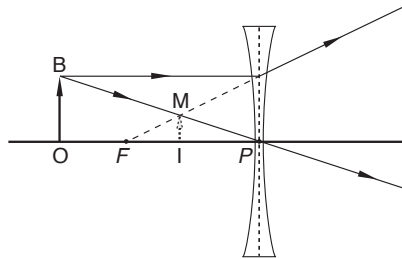


Fig. 12.74: Image formation by a concave lens.

#### Example 12.14

A convex lens has a focal length of 12 cm and a real object 6 cm tall is placed 18 cm from the centre of the lens. By means of an accurate scale diagram, find the position, size and nature of the image formed.

#### Solution

Using rays 1 and 3 of the image construction (Fig. 12.61 and 12.63), two incident rays are drawn from  $B$  and the corresponding refracted rays through the lens. The refracted rays converge at  $M$  where the image of  $B$  is formed.

Scale chosen: 1 cm = 6 cm.

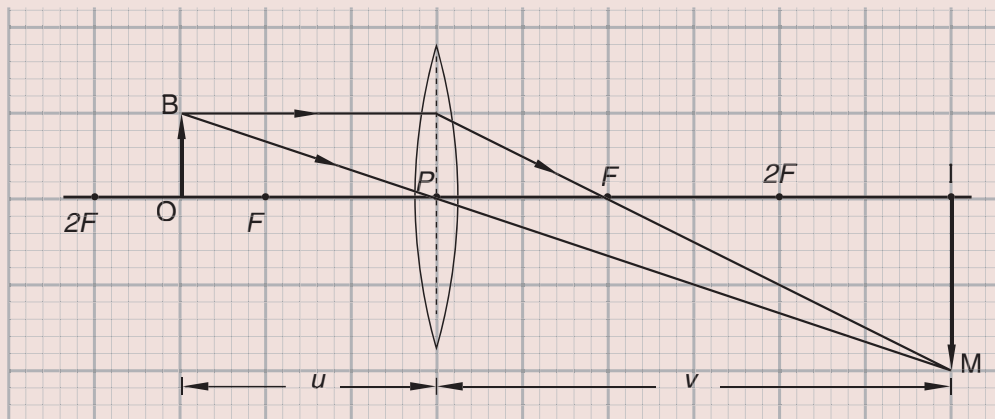


Fig. 12.75: Graphical construction of images formed by convex lens

The image of  $O$  is formed at  $I$ .  $IM$  is the real image formed at 6 cm from the lens. The height of the image is 2 cm. Since the scale is 1 cm represents 6 cm, the image is 36 cm from the lens and the height of the image is 12 cm (Fig. 12.75).



**Example 12.15**

A concave lens has a focal length of 2 cm and real object 1.0 cm tall is placed at 3 cm from the centre of the lens. By means of an accurate scale diagram, find the position, size and the nature of the image formed.

**Solution**

Scale chosen: 1 cm to represent 1 cm

Similar to Example 12.14, draw minimum two incident rays from B and the corresponding refracted rays. Since the refracted rays diverge, a virtual image is formed. The image is 1.2 cm from the lens and the height of the image is 0.4 cm (Fig. 12.76).

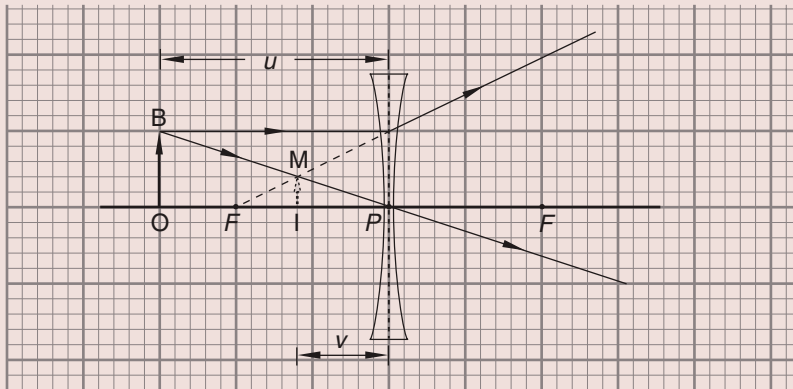


Fig. 12.76:

**Exercise 12.7**

- Name two features of the image formed by a convex lens when:
  - The object is between F and optical centre
  - The object is at F.
  - The object is at infinity.
- Sketch a ray diagram to show image formation for an object placed between 2 F and F of a converging lens. State four characteristics of the image.
- If a convex lens picks up rays from a very distant object, where is the image formed?
  - If the object is moved towards the lens, what happens to the position and size of the image?
- An object 2 cm high is placed 12 cm away from a convex lens of focal length 6 cm. By using an accurate drawing on graph paper, find the position, height and type of image.

**12.3.6 The lens formula****Activity 12.21**    **Lens formula**

Work in groups, review the relationship between similar triangles and make a report.

The lens formula is a formula relating the focal length, image and object distance. Consider a convex lens of focal length,  $f$ , which forms a real image  $IM$  of an object  $OB$  as shown in Fig. 12.77.

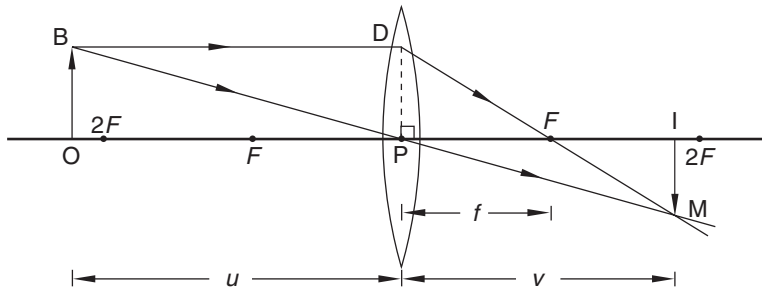


Fig. 12.77: Lens formula

Triangles  $OBP$  and  $IMP$  are similar (3 angles are equal)

$$\therefore \frac{OB}{IM} = \frac{OP}{IP} \dots\dots\dots (1)$$

Draw a line  $DP$  perpendicular to the principal axis where  $DP = BO$ . Triangles  $PDF$  and  $IMF$  are similar (3 angles are equal)

$$\therefore \frac{DP}{IM} = \frac{PF}{IF} \dots\dots\dots (2)$$

Since  $DP = OB$ , from equations (1) and (2),

$$\frac{OB}{IM} = \frac{PF}{IF}$$

$$\frac{u}{v} = \frac{f}{v-f}$$

Cross multiplying,  $uv - uf = vf$

Dividing both sides by  $uvf$

$$\frac{uv}{uvf} - \frac{uf}{uvf} = \frac{vf}{uvf} \Rightarrow \frac{1}{f} - \frac{1}{v} = \frac{1}{u}$$

Hence  $\frac{1}{f} = \frac{1}{u} + \frac{1}{v}$ . This is the **Lens formula**, where

**$u$**  stands for the distance of the object from the optical centre.

**$v$**  stands for the distance of the image from the optical centre.

**$f$**  stands for the focal length of the lens.

### 12.3.7 Sign Convention (Real is positive)

#### Activity 12.22

To show how sign conventions are used in converging lenses

#### Material

- Football

#### Steps

1. Kick a football vertically upward.
2. Observe what happens to the ball's motion.
3. How would you differentiate the two motions of the ball?

We can adopt a method or a convention to describe the upward motion and downward motion. For example let the distances up be negative and down positive or vice versa.

$$\therefore 3 \text{ m up} = -3 \text{ m}$$

$$3 \text{ m down} = +3 \text{ m}$$

There are several sign conventions used when the distances of the object and the image are measured from the lens. In this book, we shall adopt the *real is positive* in which:

1. All the distances are measured from the optical centre.
2. The distances of the real objects and the real images measured from the optical centre are taken as *positive*, while those of virtual objects and virtual images are taken as *negative*. From this convention, *the focal length of a convex lens is positive and that of a concave lens is negative*. See Fig. 12.78 (a) and (b).

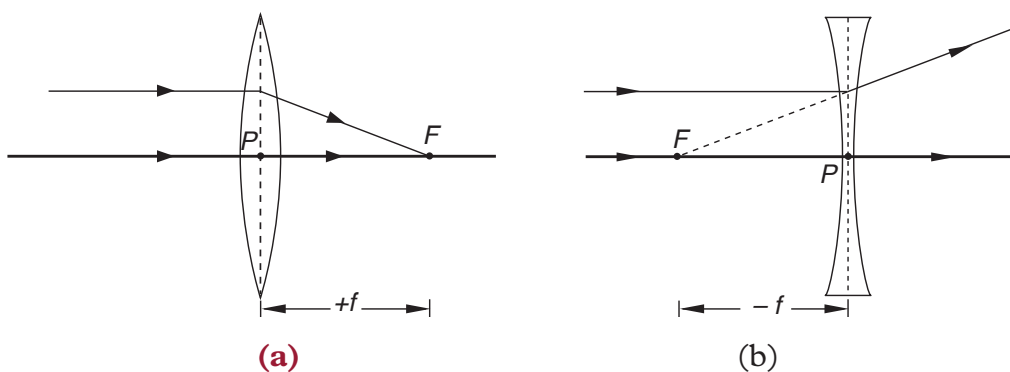


Fig. 12.78: Real and virtual focal lengths of lenses

**Example 12.16**

An object is placed 24 cm from the centre of a convex lens of focal length 20 cm. Calculate the distance of the image from the lens.

**Solution**

$$\begin{aligned}\text{From } \frac{1}{f} &= \frac{1}{v} + \frac{1}{u} \Rightarrow \frac{1}{v} = \frac{1}{f} - \frac{1}{u} \\ &= \frac{1}{20} - \frac{1}{24} \\ &= \frac{6-5}{120} = \frac{1}{120}\end{aligned}$$

The image distance ( $v$ ) = 120 cm

**Example 12.17**

An object is placed 12 cm from the centre of a concave lens of focal length 20 cm. Calculate the distance of the image from the lens.

**Solution**

$$\begin{aligned}\text{From lens formula; } \frac{1}{f} &= \frac{1}{v} + \frac{1}{u} \Rightarrow \frac{1}{v} = \frac{1}{f} - \frac{1}{u} \\ &= \frac{1}{-20} - \frac{1}{12} \\ &= \frac{-3-5}{60} = \frac{-8}{60} \\ v &= \frac{-60}{8} = -7.5 \text{ cm}\end{aligned}$$

$v$  is negative because the image is virtual.

**12.3.8 Magnification formula of the lens**

The term magnification refers to how many times an image is bigger than the object. Linear magnification ( $m$ ) is defined as the ratio of the height of the image to the height of the object.

**Activity 12.23****To derive magnification formula****Material**

- Graph papers

**Steps**

1. Draw three vertical lines on a graph paper.

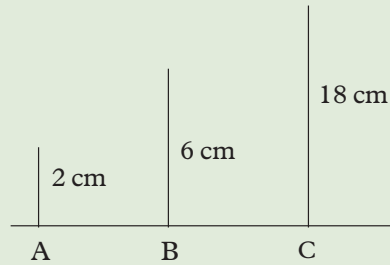


Fig. 12.79

2. How many times in line B bigger than A.
3. How many times in line B bigger than C.
4. What are the units of these comparisons?

Earlier in this unit we have done activities where we saw that the size of images formed by lenses are either bigger or smaller than the object. The increase or decrease in size of an object is called magnification. That is

$$\begin{aligned} \text{Linear magnification } (m) &= \frac{\text{height of the image}}{\text{height of the object}} = \frac{h_1}{h_0} \\ &= \frac{\text{image distance } (v)}{\text{object distance } (u)} = \frac{v}{u} \end{aligned}$$



**Note:** Since magnification is a ratio, it does not have units

Sometimes it becomes difficult to measure the height of the image or the object accurately. In such cases, magnification can be calculated in terms of distances  $u$  and  $v$ . For example, consider a convex lens where a magnified image is formed (Fig. 12.80).

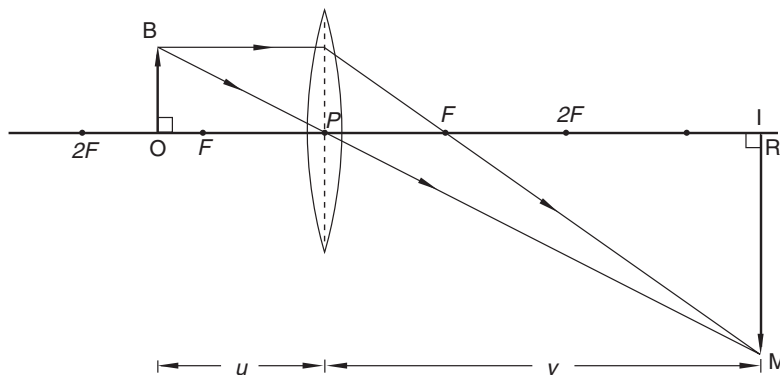


Fig. 12.80: Magnification

Since triangles OBP and IMP are similar (3 angles are equal), the ratios of corresponding sides are equal i.e,

$$\frac{IM}{IP} = \frac{OB}{OP}$$

$$\therefore \frac{IM}{OB} = \frac{IP}{OP} = \frac{v}{u}$$

Hence magnification,  $m = \frac{IM}{OB} = \frac{v}{u}$

$$\text{Magnification } (m) = \frac{\text{image distance } (v)}{\text{object distance } (u)} \text{ or } m = \frac{v}{u}$$

Therefore  $m = \frac{h_i}{h_o} = \frac{v}{u}$ , therefore, the ratio of image to object sizes  $\left(\frac{h_i}{h_o}\right)$  is also equal to the ratio of image to object distances  $\left(\frac{v}{u}\right)$  measured from the optical centre.

### Example 12.18

An object of height 2 cm is placed 20 cm in front of a convex lens. A real image is formed 80 cm from the lens. Calculate the height of the image.

#### Solution

$$m = \frac{h_i}{h_o} = \frac{v}{u} \Rightarrow \frac{h_i}{2} = \frac{80}{20}$$

$$\therefore h_i = \frac{80 \times 2}{20} = 8 \text{ cm}$$

### Example 12.19

An object placed 30 cm from a convex lens produces an image of magnification 1. What is the focal length of the lens?

#### Solution

$$\text{Magnification, } m = \frac{OB}{IM} = \frac{OP}{IP} = 1. \text{ (Fig. 12.81)}$$

Since  $m = 1$ ; then  $v = u$

This occurs when object is at  $2f$ .

Hence  $2f = 30$

$\therefore f = 15 \text{ cm}$

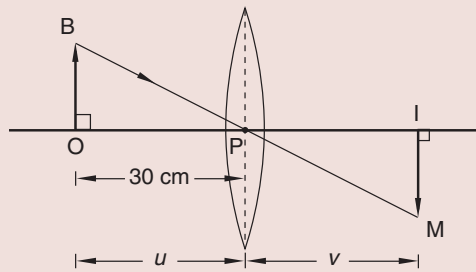


Fig. 12.81: Image formed by convex lens

### Example 12.20

An object of height 1.2 cm is placed 12 cm from a convex lens and real image is formed at 36 cm from the lens. Calculate

- the focal length of the lens
- magnification produced by the lens
- the size of the image.

#### Solution

(a) From lens formula,  $\frac{1}{u} + \frac{1}{v} = \frac{1}{f}$

$$\frac{1}{12} + \frac{1}{36} = \frac{1}{f}$$

$$\frac{3+1}{36} = \frac{4}{36} = \frac{1}{f}$$

$$\frac{1}{9} = \frac{1}{f} \Rightarrow f = 9 \text{ cm}$$

Focal length of the lens = 9 cm

(b)  $m = \frac{v}{u} = \frac{36}{12} = 3$

(c)  $m = \frac{h_i}{h_o}$

$$\therefore h_i = 3 \times 1.2 = 3.6$$

Size of the image = 3.6 cm

**Example 12.21**

An object of height 2 cm is placed 8 cm from a convex lens and a virtual image is formed on the same side as the object at 24 cm from the lens. Calculate (a) the focal length of the lens (b) the height of the image formed.

**Solution**

(a) From lens formula,  $\frac{1}{u} + \frac{1}{v} = \frac{1}{f}$

$$\frac{1}{8} + \frac{1}{-24} = \frac{1}{f} \quad (v = -24 \text{ cm because the image is virtual})$$

$$\frac{3-1}{24} = \frac{1}{f} \Rightarrow \frac{1}{12} = \frac{1}{f}$$

$\therefore$  focal length,  $f = 12 \text{ cm}$

(b) Magnification  $m = \frac{v}{u} = \frac{h_1}{h_0} \Rightarrow \frac{-24}{8} = \frac{h_1}{2}$

$$\therefore h_1 = \frac{-24 \times 2}{8} = -6 \text{ cm (negative sign indicate image is virtual)}$$

**Example 12.22**

A convex lens produces a real image of an object and the image is 3 times the size of the object. The distance between the object and the image is 80 cm. Calculate the focal length of the lens.

**Solution**

$$\text{Magnification } m = \frac{v}{u} = 3$$

$$\therefore v = 3u \dots\dots\dots (1)$$

$$u + v = 80 \dots\dots\dots (2)$$

Solving equations (1) and (2)

$$u + 3u = 80 \Rightarrow 4u = 80$$

$$\therefore u = 20 \text{ cm}$$

$$\text{Hence } v = 3u = 60 \text{ cm}$$

$$\begin{aligned} \text{From lens formula } \frac{1}{f} &= \frac{1}{u} + \frac{1}{v} = \frac{1}{20} + \frac{1}{60} \\ &= \frac{3+1}{60} = \frac{4}{60} = \frac{1}{15} \end{aligned}$$

$\therefore$  focal length,  $f = 15 \text{ cm}$



### 12.3.9 Power of a lens

#### Activity 12.24

To explain what is the power of a lens

#### Material

- A lens

#### Steps

1. Discuss with your classmates what the power of the lens is.
2. It is possible to increase the power of a lens? Discuss.
3. Share your findings with other classmates.

The ability to collect rays of light and focus them at a point in the case of a converging, or to diverge them so that they appear to come from a point in the case of diverging lens is called the **power of a lens**. It is calculated from its focal length using the formula

$$\text{Power} = \frac{1}{f}$$

The unit for power is the **dioptric** represented by the symbol **D**. The **f** must be in S.I units of length.

#### Example 12.23

A lens has a focal length of 25 cm. Find the power of the lens.

$f = 25 \text{ cm} = 0.25 \text{ m}$ . The focal length of convex lens = +ve (It forms real image)

$$\therefore \text{Power} = \frac{1}{+0.25} = +4 \text{ m}^{-1}$$

NB: For a concave lens  $f = -\text{ve}$  (because a concave lens forms a virtual image)

$$\therefore \text{Power} = \frac{1}{-0.25} = -4 \text{ m}^{-1}$$

#### Exercise 12.8

1. Define the terms: principal axis, optical centre and focal length of a convex lens.
2. With the help of a diagram, show the action of a convex lens as a converging lens.
3. The focal length of a diverging lens is 15 cm. With the help of a diagram explain the meaning of this statement.

4. Fig. 12.82 shows a convex lens of focal length 15 cm and two rays of light parallel to the principal axis.

Copy and complete the diagram to show the path of these rays as they pass through the lens. Label the position of the principal focus as  $F$ .

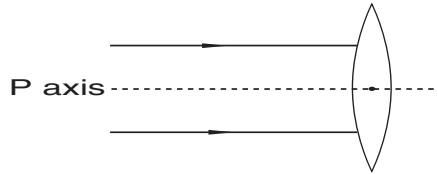


Fig. 12.82

5. Draw ray diagrams showing how a convex lens could be used to produce
- a real and diminished image
  - a virtual and magnified image of a real object.
6. Fig. 12.83 is drawn to scale. One incident ray from the object is parallel to the principal axis and other ray passes through the principal focus of a convex lens. Copy and complete the diagram to show the path of the ray through the lens. Hence determine (i) position of the image (ii) the magnification produced by the lens.

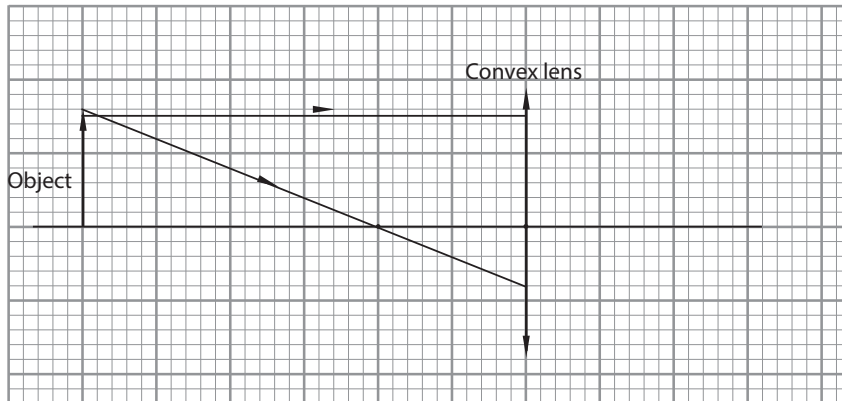


Fig. 12.83

7. Copy the table and put a tick (✓) in three of the boxes to describe the image formed by a diverging lens.

Table 12.4

Magnified	
Diminished	
Upright	
Inverted	
Virtual	
Real	

8. Draw a diagram to show how a convex lens produce a virtual image.

9. Fig. 12.84 shows two rays of light approaching a thin diverging lens. Copy and complete the diagram and show the path of the rays as they pass through and emerge out of the lens. Label the position of the principal focus  $F$ .

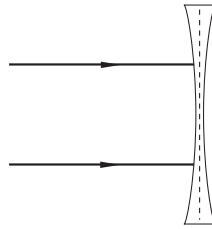


Fig. 12.84

10. Fig. 12.85 is drawn to scale. An object  $OB$  placed in front of a convex lens of focal length  $5.0\text{ cm}$ . Copy and complete the diagram and (a) show the position of the image (b) find the size of the image

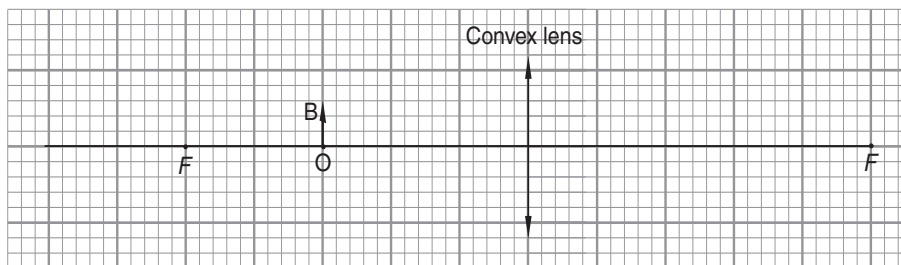


Fig. 12.85

11. A convex lens is used to form an upright, magnified image of an object placed  $6\text{ cm}$  from the lens. Calculate the focal length of the lens, if the magnification produced is  $4$ .
12. An object  $3\text{ cm}$  high is placed  $20\text{ cm}$  from a lens of focal length  $-25\text{ cm}$ . Find the position, size and the nature of the image formed.
13. At what distance must an object be placed from a convex lens of focal length  $20\text{ cm}$  so as to get real image  $4$  times the size of the object?
14. An object  $3\text{ cm}$  high is placed  $30\text{ cm}$  from a convex lens of focal length  $20\text{ cm}$   
 (a) Find the position, size and the nature of the image formed (b) If the same object is now moved by  $20\text{ cm}$  towards the lens, calculate the magnification produced by the lens.
15. A convex lens forms a focused image on a screen when the distance between an illuminated object and the screen is  $1\text{ m}$ . The image is  $0.25$  times the size of the object. Calculate (a) the object distance from the lens (b) the focal length of the lens used.
16. An object  $3\text{ cm}$  high is placed  $150\text{ cm}$  from a screen. Calculate the focal length of the lens that has to be placed between the object and the screen, so as to produce a real image  $6\text{ cm}$  high on the screen.

17. An object 6 cm high is placed 30 cm from a diverging lens of focal length 15 cm. With the help of a scale diagram determine
- the position of the image.
  - the magnification produced by the lens.
18. A real object placed 8 cm in front of a converging lens produces an image at a distance of 12 cm from the lens and on the same side as the object. Calculate the focal length of the lens.
19. A diverging lens of focal length 24 cm forms an image at 18 cm from the lens. Calculate the distance of the object from the lens.
20. In an experiment to determine the focal length of a converging lens, a student obtains the results shown in Table 12.5.

Table 12.5

$u$ (cm)	21.0	24.0	33.0	36.0	45.0	60.0
$v$ (cm)	50.0	40.0	22.5	25.0	22.0	20.0

- Plot a graph of  $u$  (x-axis) against  $v$  (y-axis)
- Using the graph, determine the focal length of the lens.

### 12.3.10 Defects of lens

#### Activity 12.25

#### To analyse the defects of a lens

##### Materials

- Converging lens
- Internet reference books

##### Steps

- Take a keen look at the lens given to you. What do you understand by the terms 'lens defect'? Do you think the lens has any defect?
- With the help of the internet and reference books conduct a research on defects of lens.
- Discuss your findings with your classmate.
- With the assistance of your teacher, make short note on defects of lenses from your findings.

In the derivations of lens formulae, we consider rays that are close to and parallel to the principal axis of the lens (**paraxial rays**). The assumption made is that the lens has a small aperture and that object points are on or close to the principal axis.

However, when we consider extended objects, the rays are **non-paraxial**. In this case the image and its object appears different from its object in colour, shape or sharpness of definition. This phenomenon is called **image defects** or **aberrations**. There are two important aberrations in lens namely; spherical aberration and chromatic aberration.

### (a) Spherical aberration

Spherical aberration is associated with lenses with a large aperture. As a result the image of an object point is not a point. The focal length of non-paraxial rays is less than for paraxial rays which is a characteristic of spherical surfaces.

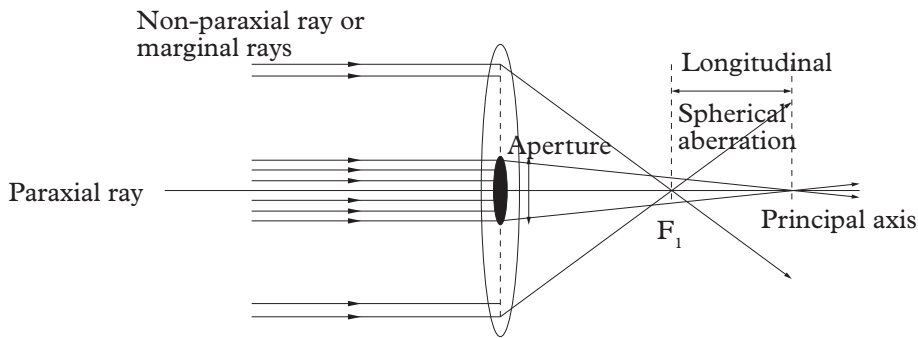


Fig. 12.86



Paraxial rays – rays parallel to and close to the principal axis

Non-paraxial rays – rays parallel to but far from the principle axis.

The image formed is a circular blurred and not a point. The distance  $F_1$  is the longitudinal spherical aberration for a particular object distance.

### Correction

1. The effect can be corrected for a given object distance by grinding the lens surface to make them spherical.
2. The effect can be reduced by cutting off the marginal rays and placing a stopper in front of a lens. This is called stopping down the lens aperture. This has the disadvantage of making the image lens bright.
3. The effect can be minimized by keeping the angles of incidence at each refracting surface small. This ensures that the deviation of light is shared or divided equally between surfaces. In the plano-convex this is achieved when curved surface receives or emits those rays which are most clearly parallel to the axis.

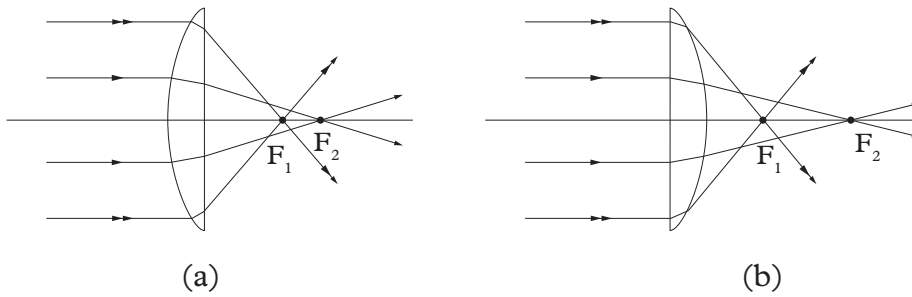


Fig. 12.87:  $F_1F_2$  in (a) is less than  $F_1F_2$  in (b)

## (b) Chromatic aberration

### Activity 12.26

### To demonstrate chromatic aberration

#### Materials

- Converging lens
- Red light
- White screen
- White light

#### Steps

1. Place a converging lens near a white screen.
2. Shine red light on the lens.
3. Locate the principal focus using red light (Fig. 12.88).

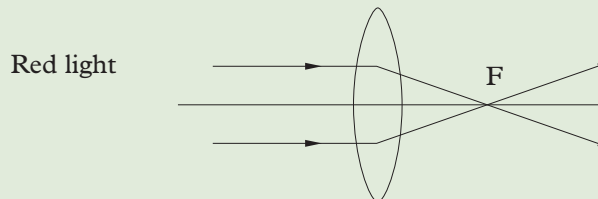


Fig. 12.88

4. Repeat steps 2 and 3 with white light. What do you observe?
5. Compare the positions of the principle focus located using the two different types of lights. Do the principal focus coincide if not, explain why.

If a white object is viewed through a converging lens, its image is blurred with coloured edges. This is because as seen above, a lens has a greater focal length for violet light than for red light. This is the case since  $\eta_{\text{violet}} > \eta_{\text{red}}$ . The effects resulting

from dispersion in which there is failure of lens to focus all colours to the same convergence point is called **chromatic aberration** (Fig.12.89).

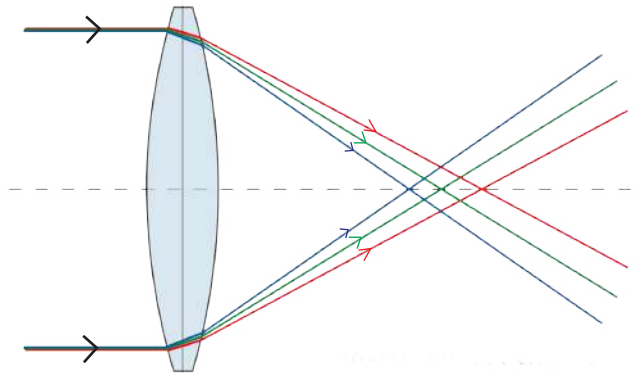


Fig. 12.89: Chromatic aberration

### Correction

This defect of a lens can be eliminated by a combination of two lens cemented together. This combination is called a **chromatic doublet**. A chromatic doublet consists of a converging lens of crown glass combined with a diverging lens of flint glass.

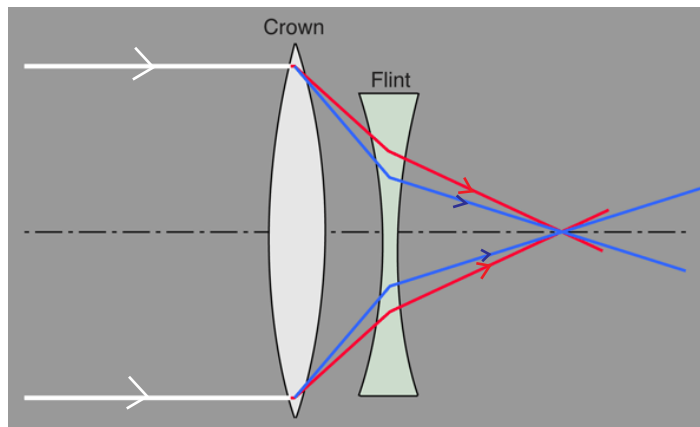


Fig. 12.90: Correction of chromatic aberration

One surface of each lens has the same radius of curvature to allow them to be cemented together using Canada balsam which reduces the loss of light by reflection.

The flint glass of diverging lens produces the same refraction as the crown glass of the converging lens but in opposite direction. The end result is a converging effect.

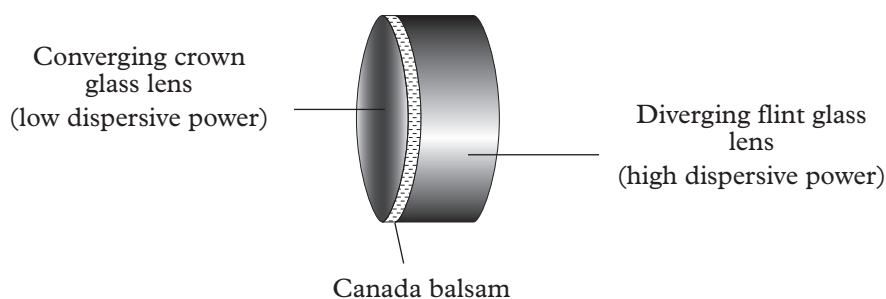


Fig. 12.91: A chromatic doublet

If the power of the lenses of the doublet give a focus point in front of the doublet, it is said to be a positive achromatic.

The idea of combining lenses to bring the image of an object into focus is used in compound lenses. How can one determine the effective focal length the compound lens? The following discussion will help us to answer this question.

### Activity 12.27

#### To demonstrate and explain lens combination

#### Materials

- Two converging lenses
- Screen
- Candle

#### Steps

1. Revisit activity 12.66. Follow the steps in the activity to locate the image of an object placed between  $F$  and  $2F$  using a converging lens.
2. Now once you locate the image move the screen and place the second converging lens on that point.
3. Move the screen to and from till you locate the image again. Where is the image located? Describe the characteristic of the image.
4. Using a simple ray diagram, draw a diagram to illustrate this lens combinations.

Consider a case of a real object placed between  $F$  and  $2F$

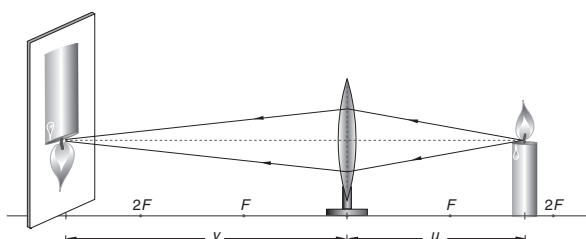


Fig. 12.92: Object between  $F$  and  $2F$



If a second converging lens intercepts the rays converging to a point, that point is the virtual object for any subsequent image.

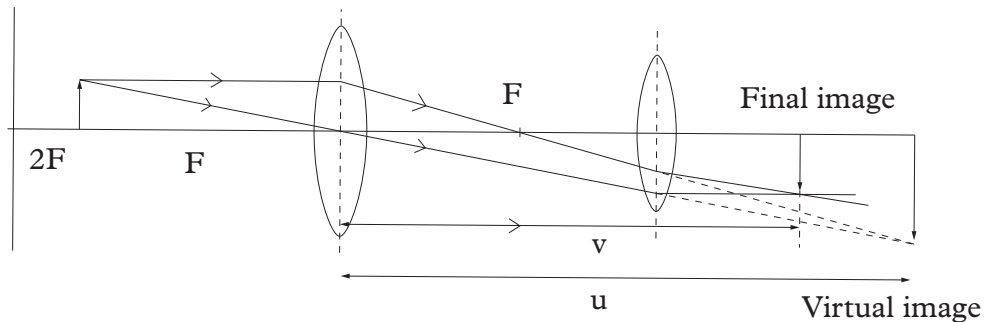


Fig. 12.93: Intercepting rays with a converging lens.

$$\frac{1}{v^1} + \frac{1}{u^1} = \frac{1}{f^1}$$

$f^1$  is the effective focal length.

### Unit summary and new words

- Refraction of light is the bending of light as it passes from one medium to another.
- Refraction of light takes place as the velocity of light is different in different media.
- Laws of refraction of light states that:
  1. The incident ray, the refracted ray and the normal to the surface at the point of the incidence are all in the same plane.
  2. The ratio of the sine of the angle of incidence to the sine of the angle of refraction is a constant for a given pair of media (this law is also known as Snell's law).
- According to Snell's law,  $\frac{\sin i}{\sin r} =$  a constant known as the refractive index of the medium with respect to air, when the incident ray is in air.
- Refractive index of a medium ( $\eta$ ) is defined as

$$\eta = \frac{\text{velocity of light in air}}{\text{velocity of light in a medium}}$$

- A pool of water appears to be shallower than the real depth, due to refraction of light.

$$\text{Refractive index of a medium} = \frac{\text{real depth}}{\text{apparent depth}}$$

- As the angle of incidence increases in a denser medium, the angle of refraction also increases in the rarer medium. Critical angle is the angle of incidence in the denser medium for which the angle of refraction is  $90^\circ$  in the rarer medium.

$$\eta_{\text{medium}} = \frac{1}{\sin c}$$

- Total internal reflection occurs when the angle of incidence in the denser medium is greater than the critical angle.
- Prism periscopes, prism binoculars, optic fibres etc., apply the properties of total internal reflection in their construction. Formation of a rainbow is due to dispersion and total internal reflection.
- A glass prism deviates a monochromatic light from its original path and the light bends towards the base of the prism.
- There is deviation as well as dispersion when white light is incident on a glass prism.
- Dispersion is the separation of white light into its component colours.  
A lens is a transparent medium bound between two surfaces of definite geometrical shape.
- Thin lenses may either be converging or diverging.
- A convex lens is thicker at its centre than its edges and converges the light incident on it.
- A concave lens is thicker at its edges than at the centre and diverges the light incident on it.
- The following are some of the important terms used in spherical lenses: principal axis, optical centre, principal focus, focal length.
- The focal length of a convex lens is positive, while that of a concave lens is negative.
- The characteristics of the image formed by a converging lens depends on the position of the object (see Table 12.6).

Table 12.6

Position of object	Position of image	Nature of image formed	Size of image formed compared to object
At infinity (far away)	$F$	real and inverted	diminished
Beyond $2F$	Between $F$ and $2F$	real and inverted	diminished
At $2F$	At $2F$	real and inverted	Same size
Between $2F$ and $F$	Beyond $2F$	real and inverted	Magnified
At $F$	At infinity (far away)	real and inverted	Magnified
Between $F$ and $P$	Same side as object	Virtual and upright	Magnified

- A diverging lens always forms a virtual, upright, diminished image between  $F$  and  $P$  (except when the object is at infinity).
- Magnification ( $m$ ) is defined as the ratio of the height of the image to the height of the object

$$\text{magnification} = \frac{\text{height of image}}{\text{height of object}} = \frac{\text{image distance}}{\text{object distance}}$$

- Lens formula is given by  $\frac{1}{u} + \frac{1}{v} = \frac{1}{f}$  where  $u$  is the object distance,  $v$  the image distance and  $f$  the focal length of the lens.
- Short-sightedness and long-sightedness are two most common defects of a human eye
- A lens camera, simple microscope, compound microscope are some examples of optical instruments.

## Unit Test 12

For questions 1 - 6, select the correct response from the choices given.

1. Bending of light is called
 

<b>A</b> Reflection	<b>B</b> Dispersion
<b>C</b> Refraction	<b>D</b> Incidence ray
2. Give the reason why the speed of light is slower in diamond than in air.

- A** Diamond is optical dense than air.  
**B** Diamond is optical less dense than air.  
**C** Diamond have a hard structure.  
**D** Diamond have soft structure.
3. The relationships between, velocity of light in air and velocity of light in a medium is given by

**A**  $\frac{\text{velocity of light in air}}{\text{velocity of light in the medium}} = \frac{1}{\eta}$

**B**  $\frac{\text{velocity of light in air}}{\text{velocity of light in the medium}} = \eta$

**C**  $\frac{\text{velocity of light in medium}}{\text{velocity of light in air}} = \eta$

**D**  $\frac{\text{velocity of light in air} \times \eta}{\text{velocity of light in the medium}}$

4. A ray of light from air to glass is incident at an angle  $35^\circ$ . Calculate the angle of refraction in the glass if the refractive index of glass is 1.50

**A**  $22.5^\circ$

**B**  $59.4^\circ$

**C**  $20^\circ$

**D**  $21.9^\circ$

5. The critical angle of a certain refracting material is  $30^\circ$ . Calculate the refractive index of the material.

**A** 1.5

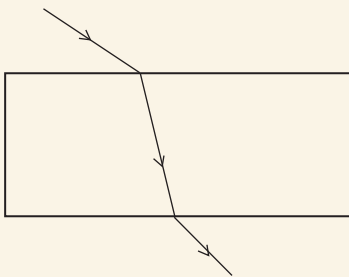
**B** 2

**C** 0.5

**D** 1

6. Which diagram in Fig. 12.94 correctly shows a ray of light passing through a rectangular glass block?

**A**



**B**

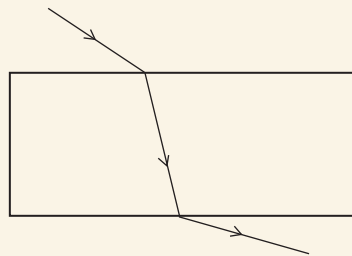


Fig. 12.94 (a) and (b): Rectangular glass block

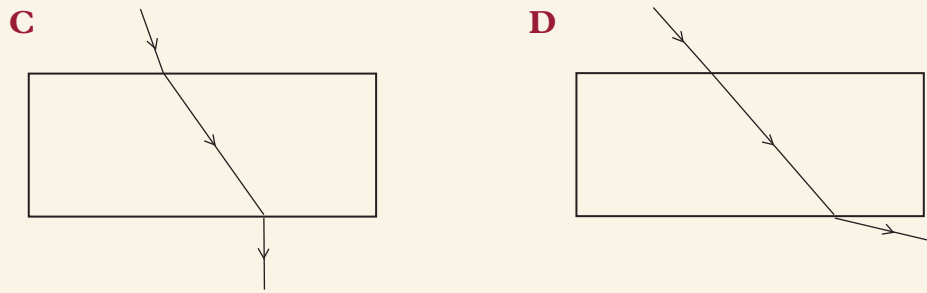


Fig. 12.94 (c) and (d): Rectangular glass block

7. Use the words provided to fill in the blank spaces.

*spectrum, deviation, refraction, dispersion, velocity, composite, monochromatic, seven*

\_\_\_\_\_ is the bending of light when it travels from one medium to another. It takes place because the \_\_\_\_\_ of light is different in different media.

9. A beam of light is incident on a glass block as shown in Fig. 12.95. Copy and complete the diagram to show the path of the beam of light in glass after refraction.

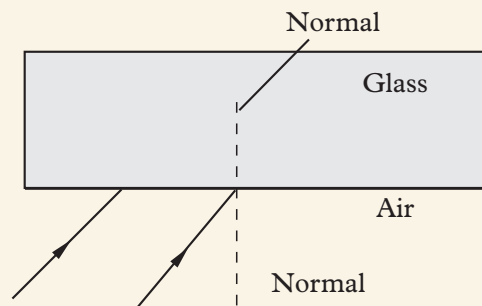


Fig. 12.95: Rectangular glass block

10. (a) Table 12.7 below gives the values of angle of incidence and angle of refraction when light passes from air into a plane glass surface. Calculate the mean refractive index of glass.

Table 12.7

$i^\circ$	$r^\circ$
25	17
40	26
70	40

- (b) The incomplete Table 12.8 shows the values of angle of incidence,  $i$ , and of angle of refraction,  $r$ , when light passes from *glass to air*.

Table 12.8

$i^\circ$	$r^\circ$
10	
30	46.5
40	

Calculate  $r$ , when  $i = 10^\circ$  and  $40^\circ$  and complete the table.

- Calculate the refractive index of diamond if the velocity of light in air is  $3.0 \times 10^8$  m/s and that in diamond is  $1.25 \times 10^8$  m/s.
- Fig. 12.96 shows a ray of light passing from air into oil. Calculate the angle of refraction in oil if the velocity of light in air is  $3.0 \times 10^8$  m/s and that in a transparent oil is  $2.2 \times 10^8$  m/s.

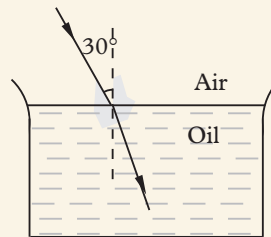


Fig. 12.96: Air-oil interface

- In an attempt to determine the refractive index of a glass block, a learner finds the displacement produced due to refraction by glass as  $d$  and apparent thickness of the block as  $y$  (Fig. 12.97). Show that the refractive index of glass may be expressed as  $\eta = \left(1 + \frac{d}{y}\right)$

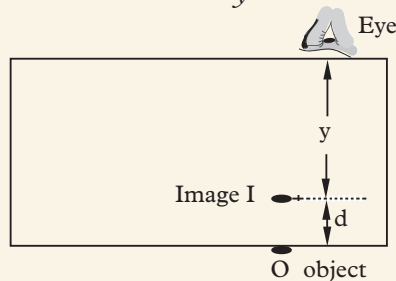


Fig. 12.97: Rectangular glass block

- A learner attempted to find the refractive index of a liquid using a concave mirror and a pin. The radius of curvature of the mirror is 20 cm. When a small quantity of a liquid was placed in the mirror, the pin had to be moved down by 4 cm. Calculate the refractive index of the liquid.
- The light ray passing from glass to air is monochromatic and has a frequency of  $4 \times 10^{14}$  Hz and a wavelength of  $5 \times 10^{-7}$  m in glass (Fig. 12.106).

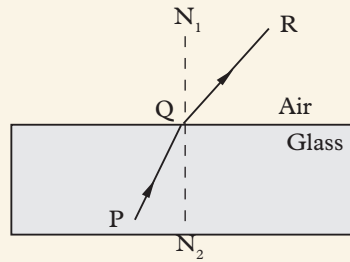


Fig. 12.98: Glass block

- (a) What is meant by monochromatic?
- (b) Calculate the velocity of light in glass.
- (c) Calculate the velocity of light in air. (Refractive index of glass is 1.50).
16. A single ray of light is incident on an equilateral glass prism as shown in the Fig. 12.99. Copy and complete the diagram to show the path of light through and out of the prism (refractive index of glass is 1.2107).

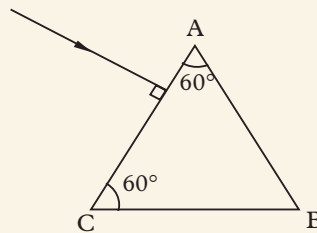


Fig. 12.99: Equilateral glass prism

17. Table 12.9 shows the reading of the angle of incidence and angle of refraction for a rectangular glass block.

Table 12.9

$i^\circ$	10	25	40	55	70	80
$r^\circ$	8	17	25	32	38	41

- (a) Draw a graph of  $\sin r$  (y-axis) against  $\sin i$  (x-axis).
- (b) What can you conclude from the graph about the relationship between  $\sin i$  and  $\sin r$ ?
- (c) Sketch another graph on the same axes in part (a), if a transparent substance of higher refractive index had been used instead of the glass block. Explain how you arrive at your answer.
18. Copy and complete the diagram in Fig. 12.100 to show the path of the ray through the prisms arranged as shown below.

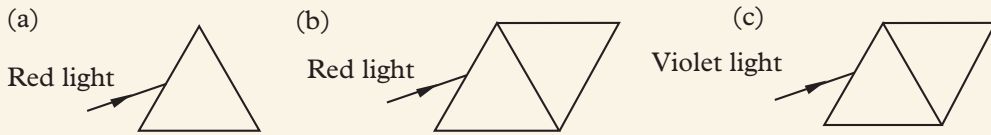


Fig. 12.100

- (a) a ray of red light is incident on the prism.  
 (b) a ray of red light is incident on 2 identical prisms placed as shown.  
 (c) the red light in (b) is replaced by violet light.
19. Describe an experiment to illustrate that white light is composite in nature.
20. Fig. 12.101, drawn to scale, shows two rays starting from the top of an object OB incident on a converging lens of focal length 2 cm.

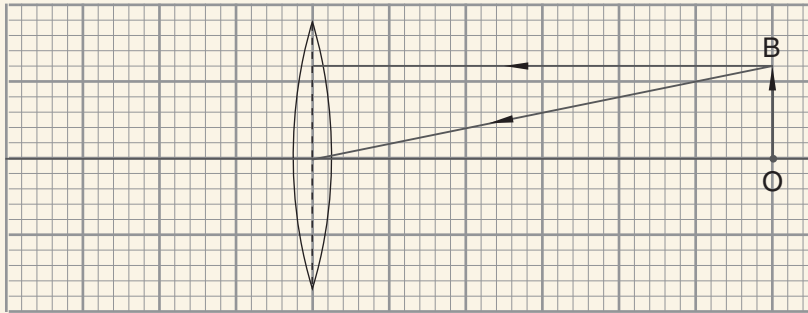


Fig. 12.101 Equilateral glass prism

- (a) Copy and complete the diagram to determine where the image is formed.  
 (b) Add one more incident ray from B through the principal focus and draw the corresponding refracted ray through the lens.  
 (c) Calculate the magnification produced by the lens.
21. Fig. 12.102 shows an object placed at right angles to the principal axis of a thin converging lens.

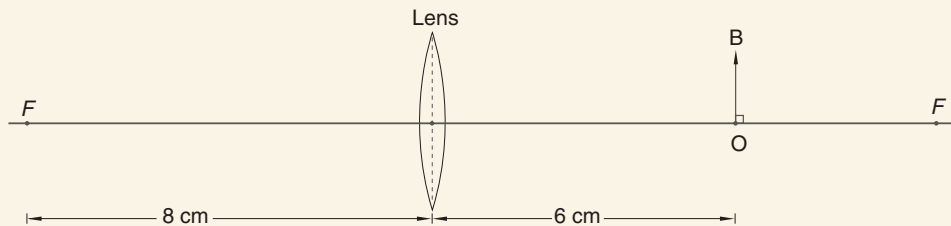


Fig. 12.102: Equilateral glass prism

- (a) Calculate the position of the image formed.  
 (b) Give an application of this arrangement of a lens.



- (c) Describe the nature of the image formed.
22. Describe with the aid of a ray diagram, how an image is formed in a (i) simple microscope (ii) lens camera.
23. A converging lens is used to form an upright image, magnified 5 times of an object placed 6 cm from the lens. Determine the focal length of the lens
24. Fig. 12.103 shows two converging lenses  $L_1$  and  $L_2$  placed 8 cm from each other. The focal length of the lens  $L_1$  is 2 cm and that of  $L_2$  is 2.8 cm. An object 1.0 cm high is placed 3 cm from lens  $L_1$ .

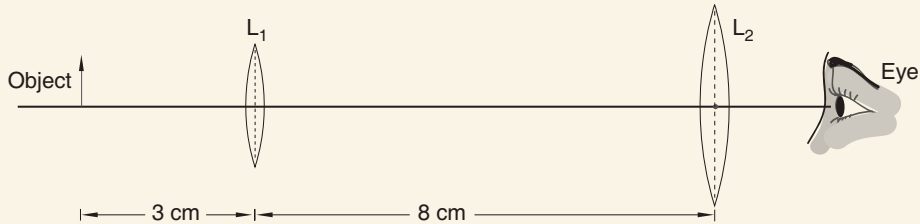


Fig. 12.103: Equilateral glass prism

- (a) Construct a ray diagram to scale, on a graph paper to show the position of the final image as seen by the eye of a person.
- (b) Determine the magnification obtained by this arrangement.

## UNIT

## 13

## Telecommunication Channels

**Key Unit Competence**

By the end of this unit the learner should be able to differentiate telecommunication channels.

**Learning objectives****Knowledge and understanding**

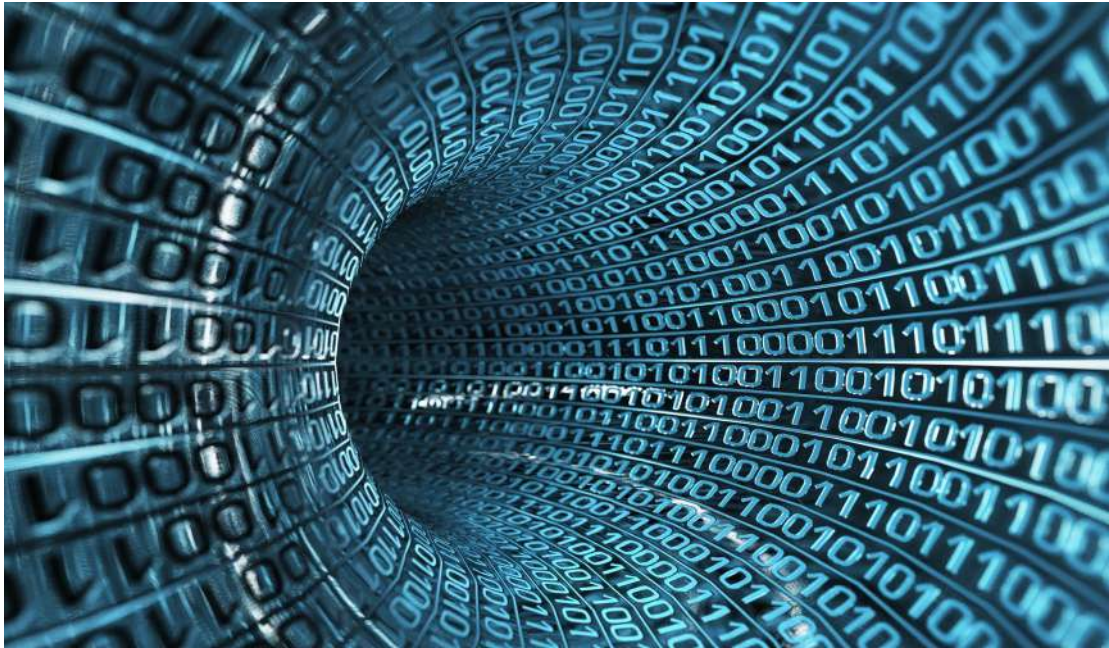
- Define and explain the term communication.
- Outline different channels of communication.
- Distinguish between digital and analogue signals.
- Explain difficulties related to signal transmission.
- Outline difficulties experienced in communication system.
- Describe simple block diagram of communication system.

**Skills**

- Apply knowledge acquired to characterize quality of a communication system.
- Use computer simulations to demonstrate channels of communication.
- Suggest different channels of communication applied in telecommunication.
- Evaluate difficulties experienced in communication system.

**Attitude and value**

- Appreciate applications of communication
- Adapt scientific techniques in analysing and modelling simple block diagram of communication systems.
- Acquire ability to deal with difficulties related to signal transmission.



## Introduction

### Unit Focus Activity

1. Identify some of the means of communication that were being used by our fore fathers in historic times and their disadvantages in terms of efficiency, timeliness, effectiveness over long distances and security/confidentiality of the message.
2. The following are some of the modern communication channels being used to transmit messages in form of data signals:

Twisted pair cables, coaxial cables, fiber optical cables, radio waves and satellite communication. Describe the types of communication where each of them is most suited.

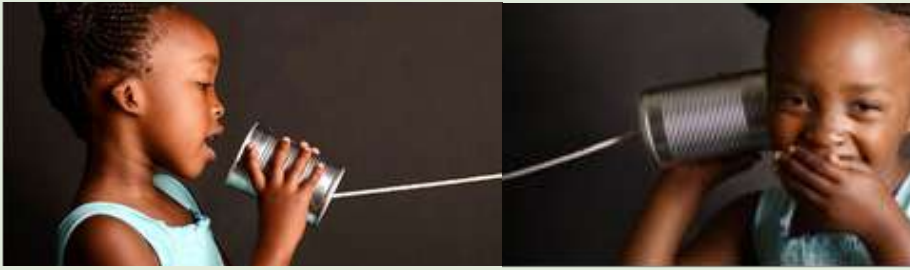
Humans are social beings and hence they have an inherent need to communicate with one another in one way or another. The need to keep on communicating is so strong that humans have from time immemorial invented better ways of passing messages to each other. In this unit, we will start by defining communication and then discuss modern communication channels.

### 13.1 Definition of terms used in communication

#### Activity 13.1

To identify and discuss the term used in communication

Figure 13.1 shows two children talking via a simple string telephone.



*Fig. 13.1: Children talking via a string telephone*

1. What do you understand by the term communication?
2. With the help of Fig. 13.1, identify five elements of a communication system.
3. Compare your elements with those identified by your classmates.

Communication is the process of using sounds, words, symbols, signs, pictures or signals to pass a message or information from one person to another. The message origin is called the source or sender while the target recipient is the receiver. The message is usually targeted for sending to the receiver.

A communication system has five basic elements

1. Message source
2. Transmitter
3. Communication channel
4. Receivers
5. Message user

### 13.1.1 Message source

This is the person who wants to send the message across the communication system. The message source may want to make a telephone call, send an email, chat etc.

### 13.1.2 Transmitter

Transmitter refers to a terminal equipment that receives a message from the source and converts it to a format that can be transmitted on the channel. A transmitter could be a computer, radio or TV transmitter station in broadcasting houses.

### 13.1.3 Communication channel

A communication channel is a transmission media through which data and information flows. A channel carries the coded message from the transmitter to the receiver using signals that can flow through it. The channel could be made of

one or more transmission media especially if the message is travelling over long distances. As mentioned in the introduction, the main focus in this unit is to explore in details the various communication channels in use in the world today.

### 13.1.4 Receivers

A receiver is a terminal equipment that gets the transmitted message from the channel and decodes it before presenting it to the user. It could be a computer, mobile phone, radio receiver etc.

### 13.1.5 Message user

This is the person who is the target recipient of the message. The message is important to the user. Figure 13.2 is a block diagram depicting the elements of a communication system.

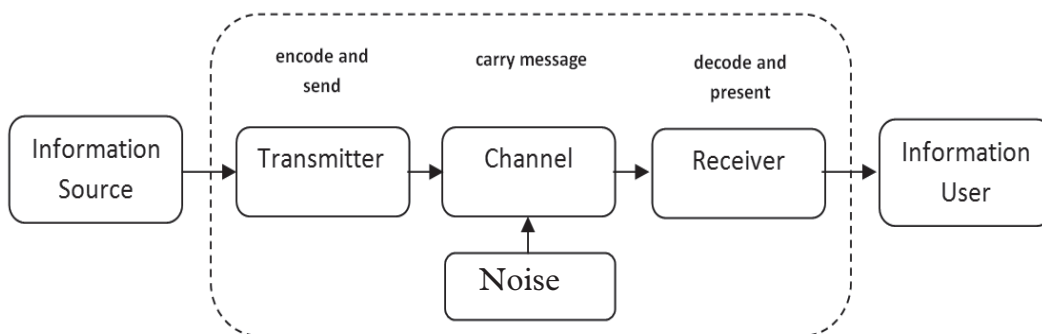


Fig. 13.2: Simple block diagram of a communication system

## 13.2 Types of data Signals

### Activity 13.2

#### To analyse types of data signals

In the year 2015, Rwanda completed what is referred to as migration from analogue to digital broadcasting.

From this understanding,

1. Point out the differences between digital and analogue signals
2. Highlight the advantages of digital data transmission over analogue transmission.
3. Present your findings to the rest of your class.

In modern telecommunication channels, the message is sent in the form of electrical signals known as **data signals**.

A data signal refers to a voltage level in the circuit which represents the flow of data. In data communication, data signals can either be **analog or digital** in nature. Analog data is made up of a continuous waveform while digital data is made up of a non-continuous discrete signal.

Figure 13.3(a) shows a digital signal represented graphically as a square wave, while Figure 13.3(b) shows an analog signal represented as a continuous sine wave.

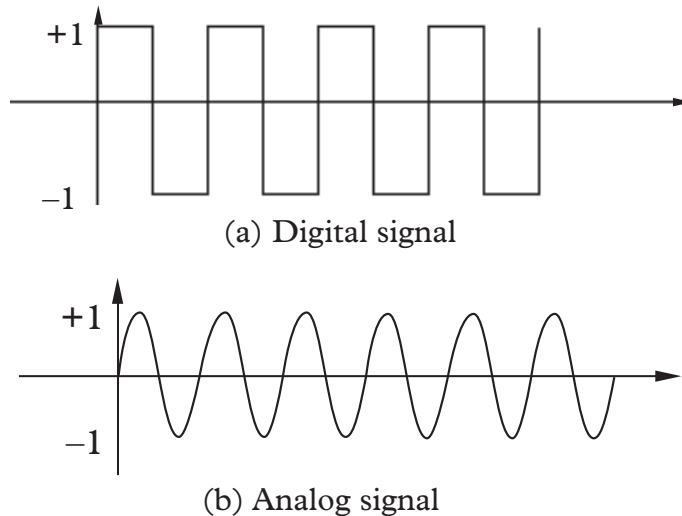


Fig. 13.3: Digital and analog data representation

Looking at Figure 13.3(a), you will observe that a digital signal rises suddenly to a peak amplitude of +1, holds for sometime then suddenly drops to  $-1$  level. On the other hand an analog signal rises to +1 and falls to  $-1$  in a continuous version (Figure 13.3(b)).

Although the two graphs look different in their appearance, notice that they repeat themselves at equal time intervals. Electrical signals or waveforms of this nature are said to be periodic. Generally, a periodic wave representing a signal can be described using the following parameters.

1. Amplitude (A)
2. Frequency (f)
3. Periodic time (T)

**Amplitude (A):** Amplitude is the maximum displacement that the waveform of an electrical signal can attain. For example, the amplitude of the electrical signals in Figure 13.3 is 1. Amplitude is the height of crest from the rest of position

-It is the depth of the trough from rest position.

-It is the distance from the crest position to the trough.

**NB:** A crest and a trough together make one cycle.

**Frequency (f):** Frequency of an electrical signal is the number of cycles made by the signal in one second. It is measured in units called Hertz (Hz). 1 Hz is equivalent to 1 cycle/second.

**Periodic time (T):** The time taken by a signal to complete one cycle is called periodic time. It is the time a vibrating object takes to make one complete oscillation.

Periodic time, T, is given by the formula  $T = \frac{1}{f}$ , where f is the frequency of the wave.

### Exercise 13.1

**For questions 1– 7, select the most appropriate answer**

- Three of the following are basic elements in a communication system. Which one is not?
 

<b>A.</b> transmitter	<b>B.</b> channel
<b>C.</b> amplifier	<b>D.</b> receiver
- If the maximum amplitude of a sine wave is 1.5 V, the minimum amplitude is \_\_\_\_\_ V.
 

<b>A.</b> 1.5 V	<b>B.</b> 1.0 V
<b>C.</b> -1.5 V	<b>D.</b> 0 V
- A \_\_\_\_\_ signal is continuous and takes continuous values.
 

<b>A.</b> digital	<b>B.</b> analog
<b>C.</b> (a) or (b)	<b>D.</b> none of these
- A \_\_\_\_\_ signal has discrete states and takes discrete values.
 

<b>A.</b> analog	<b>B.</b> digital
<b>C.</b> (a) or (b)	<b>D.</b> none of these
- What is the bandwidth of a signal that ranges from 2 MHz to 5 MHz?
 

<b>A.</b> 2 KHz	<b>B.</b> 3 MHz
<b>C.</b> 5 MHz	<b>D.</b> none of these
- A periodic signal completes 4 cycles in 0.002 s. What is the frequency?
 

<b>A.</b> 2 Hz	<b>B.</b> 200 Hz
<b>C.</b> 2 KHz	<b>D.</b> 4 KHz
- The period of a signal is 0.005 s. What is its frequency?
 

<b>A.</b> 5 Hz	<b>B.</b> 20 Hz
<b>C.</b> 0.2 KHz	<b>D.</b> 2.5 KHz



## 13.3 Data transmission media

Data signal cannot be sent from one place to another without a medium of communication. A communication medium is a physical or wireless channel used for transmitting data and information from one point to another. The communication medium will more often than not determine the type of signal used to transmit a message. In networking, data communication media can be divided into two broad categories:

1. Communication using cable (physical media)
2. Wireless communication (wireless media)

### 13.3.1 Communication using cables (physical media)

#### Activity 13.3

To analyse the use of cables in communication

1. Identify 4 types of data transmission cables in use today.
2. Evaluate the strengths (advantages) and weakness (disadvantages) of each.
3. Identity areas or conditions under which each type is most suitable.
4. Present your findings to the rest of the class.

The main distinguishing characteristic of physical media is that data is transmitted from the source to destination through a physical channel such as copper cables. For example, if the cable is a copper conductor, the data signal which may be in form of an electrical signals is propagated through the cable from the source to the destination. Degradation of the signal as it travels through the medium is referred to as signal loss. There are several types of bound transmission media but the most common ones are:

1. Two-wire open line cables.
2. Twisted pair cables.
3. Coaxial cables.
4. Fibre optic cables.

#### (a) Two-wire open line cable

Two-wire open line cable is made up of two parallel copper wires separated by a plastic insulator as shown in Figure 13.4. They are mostly used in telecommunication network to transmit voice signal.



Fig. 13.4: Two wire open lines cables



Although the plastic insulator is meant to reduce interference called **crosstalks** their linear nature allows an electromagnetic field to build around them during heavy data transmission which may cause interference to the signal. The wires also capture environmental frequencies e.g. radiowaves hence causing noise in the transmission channel. In data communications, the word noise refers to unwanted signals picked up by the channel.

### (b) Twisted pair cables

#### Activity 13.4

To describe the use of twisted pairs cables in communication

Your teacher will provide you with pieces of two different kinds of twisted power cables.

1. Observe them and discuss their structural differences.
2. Highlight the main advantage of STP cable over UTP cable.
3. Present your findings to the rest of the class.

A twisted pair cable is made up of two solid copper wires twisted around each other in a double helix manner as shown in Fig. 13.5 (a) and (b). The winding of the wires is meant to reduce the build-up of an electromagnetic field around the two wires as they transmit data. Twisted pair cables are mostly used to transmit both voice and data signals. The two common types of twisted pair cables are the unshielded twisted pair (UTP) and shielded twisted pair (STP) shown in Figures 13.5 (a) and (b).

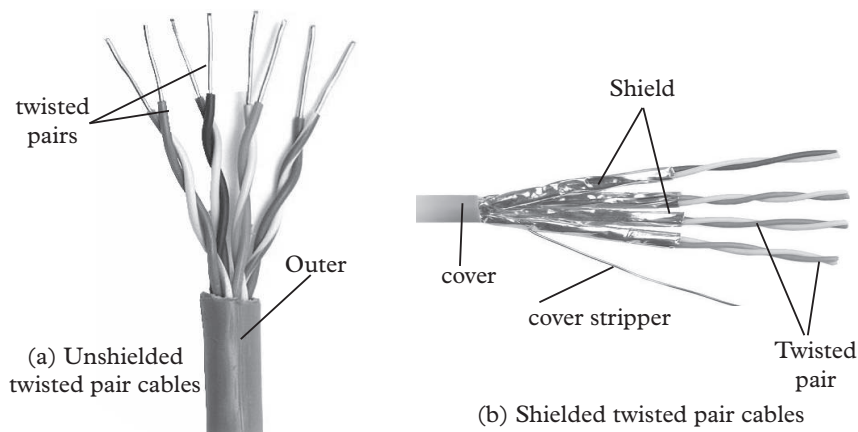


Fig. 13.5: Twisted pair cables

Notice that unlike STP, UTP cable pairs cables do not have a shield that prevents electromagnetic interference (EMI) from the environment. The cable is therefore susceptible to noise and signal interference. Noise may come from lightning

sparks, radio frequency or radiations from spark plugs in motor vehicles. Unshielded twisted pair is therefore not suitable for environments that are electrically “noisy”. The alternative is to use STP that has cable pairs. Shielded twisted pair (STP) is similar to unshielded twisted pair except that a shield is wrapped around the wires to protect them from noise.

Although twisted pair cables support high data rates of upto 100 Mbps, they suffer from attenuation. For every cable length of 90 metres, a device for amplifying the signal called a “repeater” must be installed.

### Example 13.1

A student typed an e-mail to send over the internet at a speed of 100 Mbps. Calculate the maximum number of characters that can be sent per second if each character consists of 8 bits.

#### Solution

$$\begin{aligned} \text{Characters per second} &= \frac{100 \times 1 \times 10^6}{8} = \frac{100 \times 1\,000\,000}{8} \\ &= 12\,500\,000 \text{ characters per second} \end{aligned}$$

#### *The advantages of twisted pair cabling include:*

1. It is easier to set up network media because UTP cables are widely available.
2. Devices used to setup UTP connection are cheap and readily available.
3. UTPs are cheaper because of mass production for telephone use.

#### *The disadvantages of twisted pair cabling include:*

1. UTP connection suffers high attenuation rate.
2. It is sensitive to electromagnetic interference and eavesdropping.
3. It has low data transmission rate as compared to fibre optic cables.

### (c) Coaxial cables

#### Activity 13.5

#### To analyse the use of coaxial cables in communication

Your teacher will provide you with a piece of TV cable that you use at home to connect the antennae to your television set.

With the help of research from books or the internet:

1. Draw its structure and label all its parts
2. Discuss the function of each part.

A coaxial cable resembles the cable that is used to connect television antenna to a television set. It is called coaxial cable because it has a copper core (coax) which may be of solid copper wire surrounded by a dielectric material as shown in Fig 13.6 (a). The **dielectric** material is then surrounded by mesh conductor which is covered by a shield making the cable more resistant to electromagnetic interference than the twisted pair cable.

The mesh conductor is made of copper or aluminium and serves as the earthing for the carrier copper core. Together with the insulation and any foil shield, the shield protects the core from radio frequency interference (RFI) and electromagnetic interference (EMI). Although the cable has better protection against electrical interference than the twisted pair cables, it has a moderate protection against magnetic interference. The diameter of the centre core determines the attenuation rate. The thinner the core, the higher the attenuation rate. Data is carried on coax in the form of direct current (d.c).

Coaxial cables have bandwidths of upto 1 Gbps (Gigabits per second) hence, they are used as network backbone. A good example where these cables are used is connecting different networks between buildings and routing trunk calls in telecommunication. There are two types of coaxial cables:

1. Thin coaxial cable also known as thinnet that has one dielectric insulator as shown in (Figure 13.6 (a)).
2. Thick coaxial cable also known as thicknet that has two dielectric insulators around the core and is thicker than the thinnet (Figure 13.6 (b)).

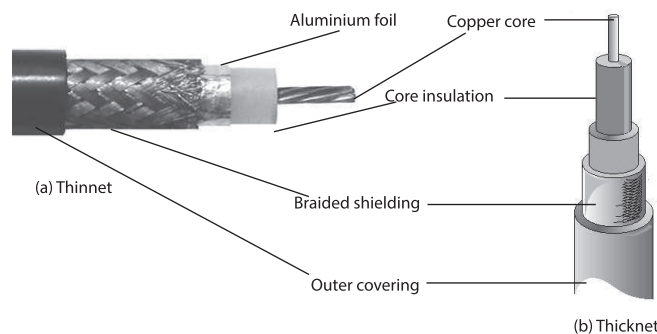


Fig. 13.6: Thinnet and Thicknet coaxial cables

***Advantages of coaxial cables include:***

1. They are stable even under high transmission loads.
2. They have high bandwidth compared to twisted pair cables.
3. They are capable of carrying voice, data and video signal simultaneously.

4. They are more resistant to radio, and electromagnetic interference than twisted pair cables.

***Disadvantages of coaxial cables include:***

1. Thick coaxial cable is hard to work with.
2. Coaxial cables are relatively expensive to buy and to install as compared to twisted pair.
3. Local area network established using coaxial cable is difficult to troubleshoot and maintain. This has made coaxial cabling unpopular in LANS hence the wide usage of twisted pair cables.

**(d) Fibre optic cables**

**Activity 13.6**

**To analyse the use of fibre optic cables in communication**

“Optical cables have become the most reliable and efficient channels of data transmission”.

1. Discuss three justifications for this proposition.
2. Draw and label the structure of an optical cable on a manila paper.
3. Discuss the function of each part.
4. Illustrate with a diagram the process of data transmission in the cable.

Fibre optic is one of the latest physical transmission media to be used in local and wide area networks. Instead of transmitting data signals using electronic signals, fibre optic cable uses light to transmit data from one point to another on the network. The electrical signals from the source are converted to light signals, then propagated along the cable. To convert electrical signal to light, the source has a transmitter system made of light emitting diode (LED). At the receiving end, a photosensitive device is used to convert the light back to electric signals. The fibre optic cable is made up of the **core, cladding, buffer, strength members and the jacket**.

- **Core:** The core is the central part of the cable and is made of a hollow transparent plastic or glass.
- **Cladding:** This is a single protective layer surrounding the core. It has some light bending characteristics in that, when the light tries to travel from the core to the cladding, it is redirected back to the core. This is why even if a fibre optic cable is bent into coils and a light signal is inserted at one end it will still be seen coming out from the other end.

- **Buffer:** The buffer surrounds the cladding and its main function is to strengthen the cable.
- **Jacket:** It is the outer covering of the cable.

Fibre optic cables can be classified into two categories namely: Single mode and multimode fibre optic cables.

The single mode fibre cable has a very narrow centre core (Figure 13.7 (a)). The light in the cable can therefore take only one path through it. Because of this, it has a very low attenuation rate and is preferred for long distance transmission. It has a bandwidth of 50 Gbps which is higher than that of the twisted pair's 100 Mbps. Single mode fibre is very expensive and requires very careful handling during installation.

Multimode fibre cable has a thicker core than the single mode (Figure 13.7 (b)). It allows several light rays to be fed in the cable at an angle. Because of multiple light signals navigating the cable at the same time, distortion of the signal is possible. Multimode cables have a high attenuation rate and are usually used for shorter distances than single mode.

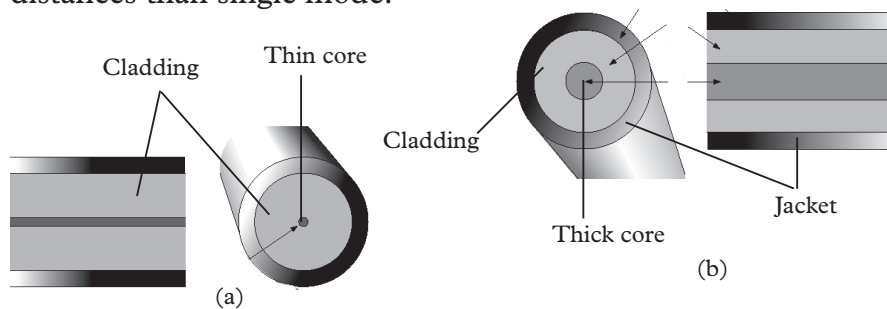


Fig. 13.7 (a) Single mode fibre cable (b) Multimode fibre cable

In fibre optic cables, the data signal travels as light through the core due to total **internal reflection**. Total internal reflection occurs when light travels from optically dense medium such as glass to less optically dense medium such as air. The phenomenon that causes total internal reflection is called **refraction**. When light travels from optically dense medium, it is refracted away from the normal to a point that the ray deviates so far away from normal making it reflected rather than being refracted. When light signal is fed into fibre optic cable, it rises to cross from the core to the cladding. The light is bent back into the core and hence propagated along the length of the cable as shown in Figure 13.8.



Fig. 13.8: Multimode fibre

Figure 13.9 below shows how a fibre based network transmits data from source to destination.

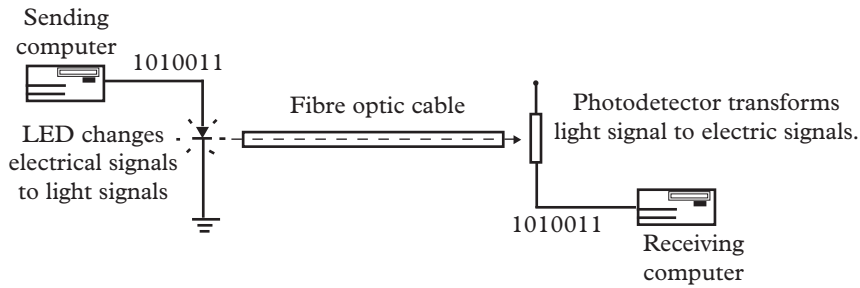


Fig. 13.9: Fibre network

***The advantages of fibre optic cabling include:***

1. Fibre optic cable is immune to electromagnetic interference and eavesdropping.
2. Fibre optic cables supports high bandwidth.
3. It can be used as backbone in wide area networks because it has low attenuation.
4. Can be used in highly flammable places because they do not generate electrical signal.
5. Fibre optic cable is smaller and lighter than copper cables hence good for space between ceiling and rooftop.

***The disadvantages of fibre optic cabling include:***

1. Installation and configuration of fibre optic network devices and the media are expensive.
2. Installation is difficult because the cable is dedicated.
3. Fibre optic network is difficult to troubleshoot and complex to configure.

### Exercise 13.2

**Part 1: Select the most appropriate answer.**

1. \_\_\_\_\_ cable consists of an inner copper core and a second conducting outer sheath.
 

<b>A.</b> Twisted-pair	<b>B.</b> Shielded twisted-pair
<b>C.</b> Coaxial	<b>D.</b> Fiber-optic
2. In an optical fibre, the inner core is \_\_\_\_\_ the cladding.
 

<b>A.</b> less dense than	<b>B.</b> denser than
---------------------------	-----------------------

- C.** the same density as                      **D.** another name for
3. \_\_\_\_\_ cable is used for voice and data communications.  
**A.** Twisted-pair                                      **B.** Coaxial  
**C.** Fiber-optic                                      **C.** All of these
4. \_\_\_\_\_ cables carry data signals in the form of light.  
**A.** Twisted-pair                                      **B.** Coaxial  
**C.** Fiber-optic                                      **D.** one of these
5. In a fiber-optic cable, the signal is propagated along the inner core by \_\_\_\_\_.  
**A.** refraction                                      **B.** total internal reflection  
**C.** modulation                                      **D.** none of these
6. \_\_\_\_\_ cables are very cheap and easy to install, but they are badly affected by the noise interference.  
**A.** STP    **B.** UTP  
**C.** Co-axial    **D.** Optical Fiber
7. Twisting of wires in twisted pair cable helps to  
**A.** increase the data speed  
**B.** reduce the effect of noise or external interface  
**C.** make the cable stronger  
**D.** make the cable attractive
8. Signals with a frequency above 30 MHz use \_\_\_\_\_ propagation.  
**A.** line-of-sight                                      **B.** sky  
**C.** ground    **D.** none of these
9. Twisted pair cables offers data rates up to \_\_\_\_\_  
**A.** 100 Mbps    **B.** 15 Mbps  
**C.** 20 Mbps    **D.** 25 Mbps
10. State whether the following statements are True for twisted pair cable.  
**(i)** Signal attenuation is lower in STP than in UTP  
**(ii)** The cost of UTP is higher than STP  
**(iii)** The installation of UTP is fairly easy than STP  
**A.** (i) and (iii) only                                      **B.** (i) and (ii) only  
**C.** (ii) and (iii) only                                      **D.** All (i), (ii) and (iii)

11. \_\_\_\_\_ is the overlapping of frequency bands, which can distort/wipe-out a signal.
- A.** Noise    **B.** Attenuation  
**C.** Interference                                      **D.** Distortion
12. What is the major factor that makes coaxial cable less susceptible to noise than twisted-pair cable?
- A.** insulating material                              **B.** inner conductor  
**C.** diameter of cable                              **D.** outer conductor
13. Which of the following are the advantages of fiber optic communication over other conventional means of communication.
- (i)** Small size and light weight  
**(ii)** Easy availability and low cost  
**(iii)** No electrical or electromagnetic interference  
**(iv)** Large bandwidth
- A.** (i), (ii) and (iii) only                          **B.** (ii), (iii) and (iv) only  
**C.** (i), (iii) and (iv) only                          **D.** All (i), (ii), (iii) and (iv)

**Part 2**

- A \_\_\_\_\_ fibre has a thick core while a \_\_\_\_\_ fibre has a narrow one.
- Multimode fibre has high attenuation because of \_\_\_\_\_.
- \_\_\_\_\_ is caused by refraction of light at the critical angle of incidence.
- State one factor that affect the attenuation rate of a fibre cable.
- Highlight two advantages and disadvantages of the following cables:  
**(a)** Coax                      **(b)** UTP                      **(c)** Fibre                      **(d)** Two wire open lines
- Describe the fibre optic data transmission system. Draw a diagram to illustrate its elements.

**13.3.2 Wireless communication****Activity 13.7****To identify wireless communication channels**

Match the cited communication to the wireless communication channels used.

TV remote device to TV set	Blue tooth
Continent to continent	Infrared
Between two distant mobile phones	Satellite
From a phone to a computer	Radio waves



Wireless transmission medium is used to transmit data from one point to another through non-physical channel. Examples of wireless transmission media include microwaves, satellite, radiowaves, and infrared all of which use different frequencies of the electromagnetic spectrum shown in Figure 13.10.

In this section, we discuss three types of wireless transmission media namely; microwaves, radiowaves and infrared waves.

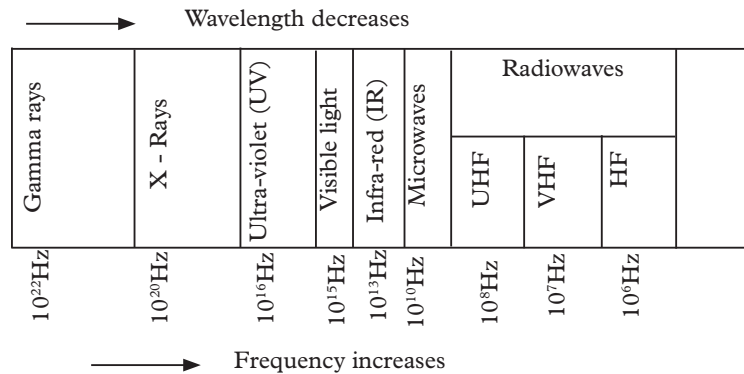


Fig. 13.10: The electromagnetic spectrum

**(a) Microwave transmission**

Microwave frequencies range from about 3GHz to 40GHz on the electromagnetic spectrum. Due to small wavelength, microwaves easily release energy in water as heat hence they are also used in making microwave ovens used as domestic appliances. In networking, microwaves are suitable for point to point transmissions. This means that, a signal is directed through a sharp beam from transmitter to receiver station. Figure 13.11 shows an illustration of point-to-point transmission in microwaves connecting two local area networks in different buildings.

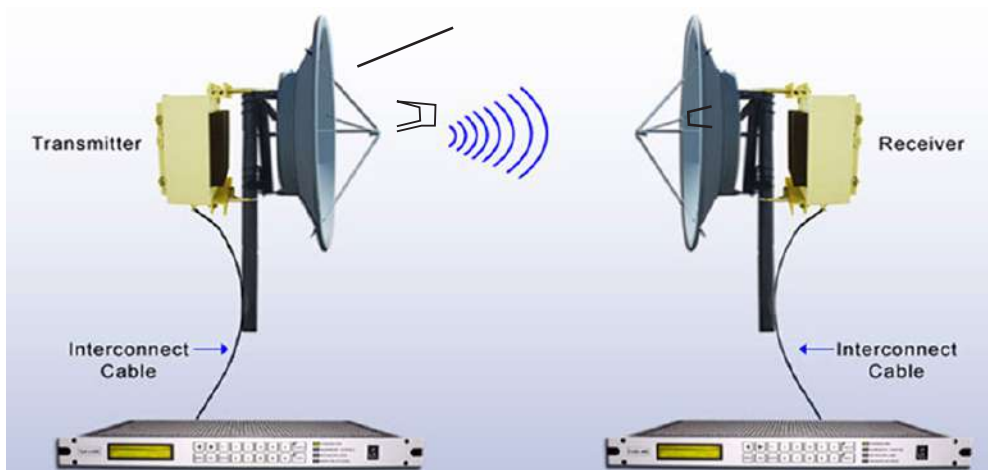


Fig. 13.11: Point to point microwave transmission

**(b) Satellite communication****Activity 13.8****To analyse satellite communication**

1. Draw and label a conceptual diagram depicting a satellite communication system.
2. Highlight the advantages of satellite communication system.

A satellite is a special type of microwave relay station in space. The satellite earth stations are microwave dishes with antenna used for relaying a narrow beam to the satellite in space. A satellite transmission system has three main components:

1. **Transmitter earthstation** that has uplink frequency for transmitting data to the satellite.
2. **Satellite** that is relay station in orbit that receives, amplifies and retransmits the signal to a receiver earth station via a downlink frequency that is different from the uplink frequency.
3. **Receiver earthstation** that receive data signals from the satellite. Figure 13.12 shows an illustration of a satellite system.

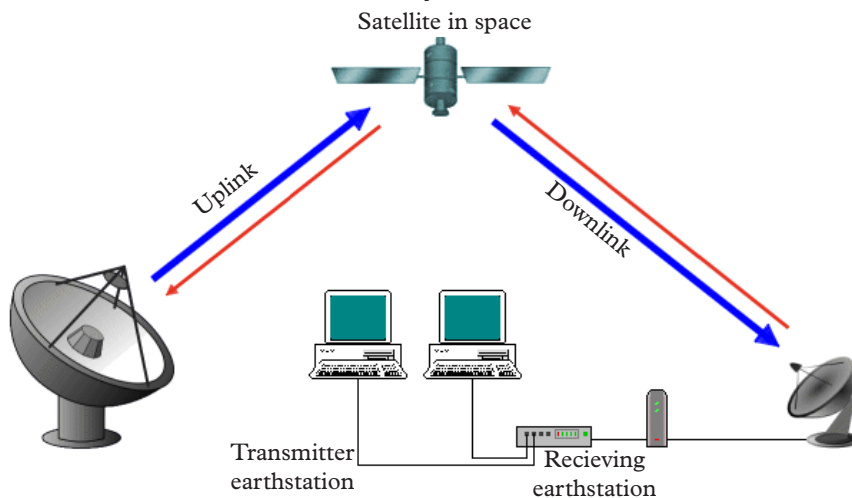


Fig. 13.12: Satellite transmission system

Communication satellites used for data transmission are usually launched into space about 36 000 km above the earth in such a manner that their rotational speed is relatively equal to that of the earth. An observer on earth will therefore see as if the satellite is stationary in space. These type of satellites are called **geostationary** satellites. They are convenient because they eliminate the task of moving parabolic dishes in a bid to track the line of sight. A geostationary satellite offers a large constant line of sight to earthstations. The area where the line of

sight can easily be located is called the satellite's footprint. The satellite transmits the signal to many earthstations to form a point to multipoint transmission. In multipoint transmission the transmitted signal scatters in all directions forming a cell of access radius.

New trends in microwave transmission systems has seen the use of very small **aperture terminal** (VSAT) technology. Very small aperture terminal refers to a small satellite dish used in data, radio and TV communication. In recent times, most organizations have mounted VSAT in order to access satellite communication directly instead of having to go through state owned gateways. Figure 13.13 shows how VSAT is used to connect two locations to a communication network set up to enable two laptops in geographically disperate locations to communicate.

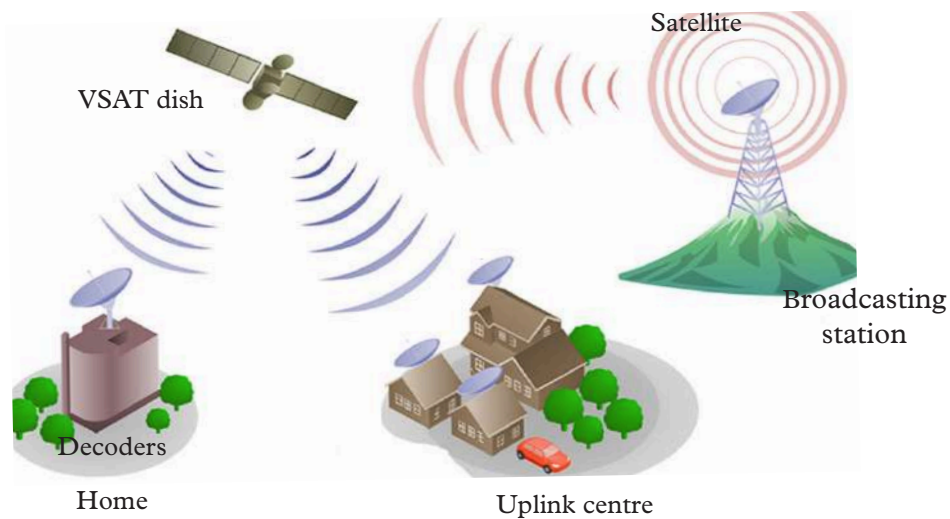


Fig. 13.13: VSAT technology

In VSAT, a satellite produces strong signals that can be received by a dish of only 2 metres in diameter. The signals are decoded using a decoder which is plugged directly to a television set or a computer.

### (c) Radio communication

#### Activity 13.9

#### To analyse radio communication

1. Describe the acronym names HF, VHF and UHF in regard to radio waves.
2. Sketch a conceptual diagram showing the transmission of HF radio waves from a broadcasting station the radio receiver.
3. Identify three uses of radio waves in our daily lives.

Radio waves travel just like surface water waves, i.e. they are omnidirectional. This means that radiowaves start from a central point and spread outwards in all directions. As they travel outwards, the energy emitted by the waves spreads outwards over the covered area. The waves are radiated into the atmosphere by a radio frequency antenna at constant velocity. Radio waves are not visible by human eye. Figure 13.14 shows how radio waves are propagated between the transmitting station and the receiving station.

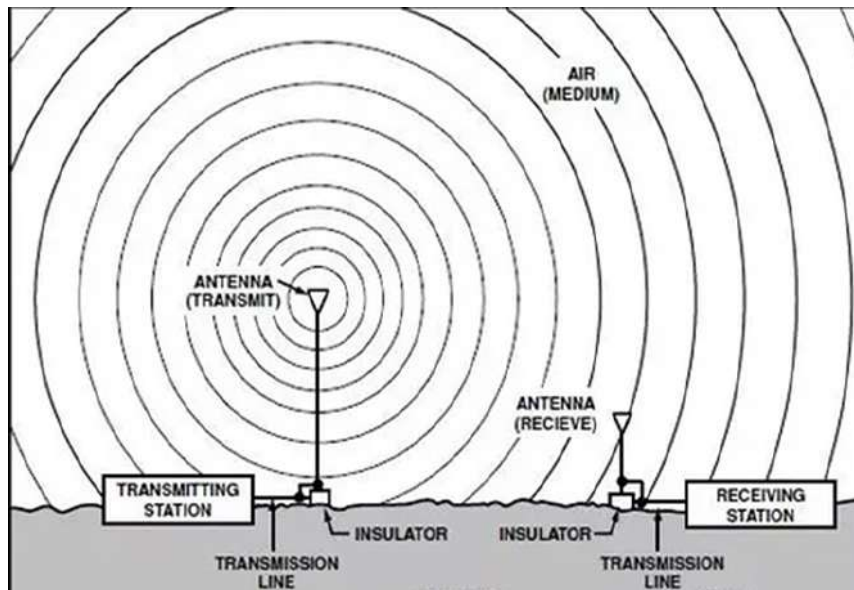


Fig. 13.14: Radio waves transmission

Radio waves are used in radio and television broadcasts. Data can also be transmitted over radiowaves communication channels. For example, instead of installing telephone cables between two distant towns, radiowaves can be used to connect the two towns. Radiowaves can be of high frequency, very high frequency or ultra-high frequency.

The high frequency (HF) radio waves signal is propagated by directing it to the ionosphere of the earth as shown in Fig 13.15. The ionosphere reflects it back to the earth's surface and the receiver picks the signal. Before invention of satellite communication, high frequency radio transmission was a preferred mode of communication in marine transport to direct ships and other maritime objects. However, the main drawback in use of high frequency communication is the danger of signal interception by unauthorised parties.

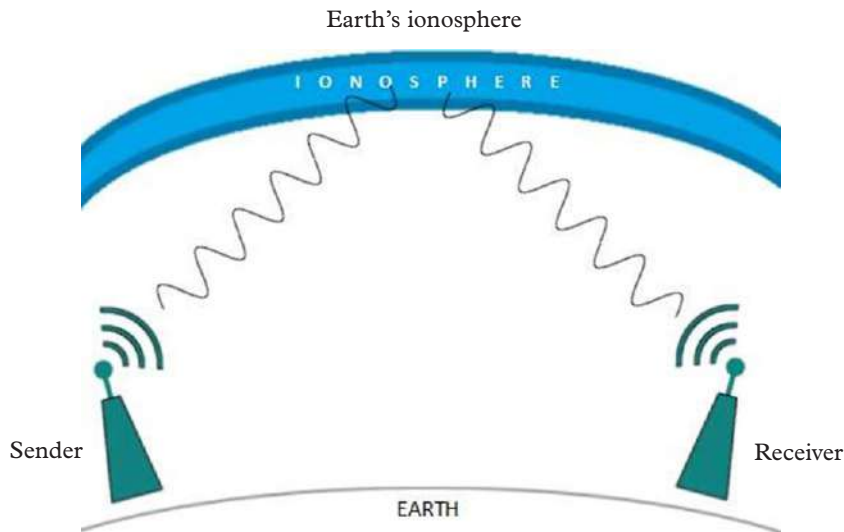


Fig. 13.15: HF radio transmission

Very high frequency (VHF) radio waves are transmitted along the earth's surface. Due to shape of the earth, the signal attenuates mostly at the horizon. This means that repeater stations have to be placed strategically to maintain a line of sight in order to receive, amplify and propagate the signal. Very high frequency is mostly used on hand held radio devices like "walkie-talkie" radios. The range of VHF is limited but it is preferred to high frequency where no major obstructions are encountered. This is because with very high frequency, it is possible to make the radiowave follow narrow and more precise or focussed path to the receiver. To overcome the obstructions by the earth surface like mountains and buildings, repeater stations are built on high grounds like hills and mountains.

Ultra high frequency (UHF) radiowaves are very high frequency when it comes to the line of sight principle. This means that there should be no barrier between the sending and the receiving stations. Notice that the television aerial for very high frequency is bigger than the one for ultra high frequency radiowaves. This is because UHF radiowaves can be made to follow very narrow and precise path to the receiver than VHF radiowaves. Therefore, ultra high frequency is popular for horizon limited broadcasts.

#### **(d) Bluetooth transmission**

One of the latest short range radio transmission technologies is called bluetooth technology. Bluetooth is short range radio transmission that enables devices located within a limited geographical location to communicate and share resources such as files. The main objective of bluetooth communication is to define a common standard that allows most devices regardless of their architectural or software differences to share data and other resources. The main component in bluetooth is a small low power two-way radio transceiver, small enough to be inserted in

small devices. A network of bluetooth-enabled devices is called a wireless personal area network (WPAN) or piconet because bluetooth networks are best suited for hand held devices. This has made radio transmission become popular in mobile communication and Internet connectivity. Figure 13.16 shows a piconet between a mobile phone and a portable computer.



Fig. 13.16: A piconet of two devices

### (e) Infrared transmission

Infrared waves fall below visible light on the electromagnetic spectrum. Like the radiowaves, infrared waves are not visible to the human eye. Communication through infrared is achieved by having transmitters and receivers (transceivers). Transceivers of infrared signals must be within a line of sight because unlike radio signals, they cannot penetrate obstacles like walls. However, the signal can be reflected by surfaces like walls and ceiling before they are received.

An example of an infrared device is the transceiver installed on some mobile phones. Once activated, two people in the same room can send messages to each other using infrared without going through the mobile service provider hence saving on network charges.

In networking, infrared can be used to connect devices without need for cables e.g. connecting a computer to a printer.

### *Advantages and disadvantages of wireless communications*

Wireless communication offers numerous advantages which justify the cost of installation. Some of the advantages are:

1. Wireless transmission is flexible compared to physical media i.e. devices can be moved around without disconnecting them.

2. Wireless networks can span large geographical areas.
3. Wireless communication can take place via satellite even in remote areas that do not have physical infrastructure like telephone lines.

***Some of the disadvantages of wireless communications include:***

1. It is relatively difficult to establish or configure.
2. The initial set up cost may be high.

### Exercise 13.3

**Part 1: Select the most appropriate answer from the choices given.**

1. \_\_\_\_\_ are used for mobile phone, satellite, and wireless network communications.
 

<b>A.</b> Radio waves	<b>B.</b> Infrared waves
<b>C.</b> Microwaves	<b>D.</b> none of these
2. \_\_\_\_\_ are used for short-range communications such as those between a PC and a peripheral device.
 

<b>A.</b> Radio waves	<b>B.</b> Infrared waves
<b>C.</b> Microwaves	<b>D.</b> none of these
3. Which of the following primarily uses guided media?
 

<b>A.</b> radio broadcasting	<b>B.</b> satellite communications
<b>C.</b> local telephone system	<b>D.</b> cellular telephone system
4. \_\_\_\_\_ use line of sight propagation
 

<b>A.</b> Radio waves	<b>B.</b> Microwaves waves
<b>C.</b> Infrared	<b>D.</b> none of these

**Part 2: Fill in the gaps.**

1. The \_\_\_\_\_ depicts the various frequencies and wavelengths of electromagnetic waves.
2. The \_\_\_\_\_ waves have smaller wavelengths, require smaller aerials for reception and are suited for metropolitan broadcasts.
3. In a satellite transmission system, the \_\_\_\_\_ frequency must be different from the \_\_\_\_\_ frequency to avoid interference.
4. A \_\_\_\_\_ satellite is usually launched approximately \_\_\_\_\_ km above the earth's surface and set to circle the earth at a speed that makes it to appear stationary to a passive observer on earth.



5. A device can receive a satellites signal only if it is within the satellites.
6. \_\_\_\_\_ is a contemporary satellite technology for transmitting satellite content to offices and homes without installing the large satellite dishes.

### 13.4 A simple block diagram of communication system

The elements of basic communication system are as follows

- Information or input signal
- Input Transducer
- Transmitter
- Communication channel or medium
- Noise
- Receiver
- Output Transducer

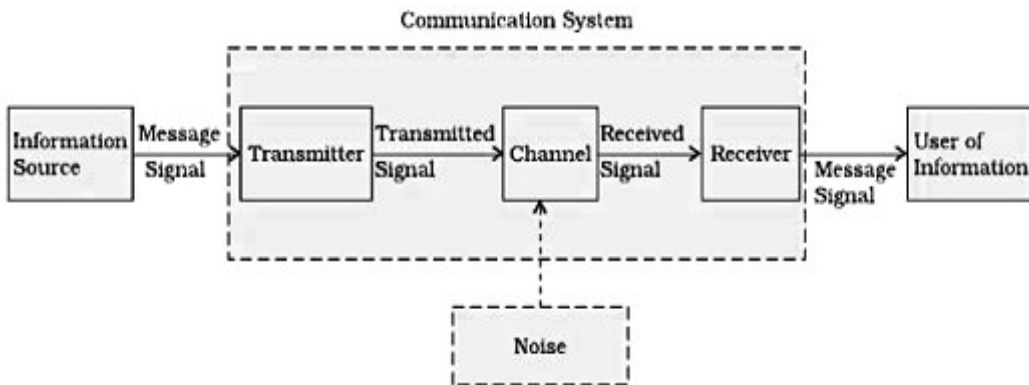


Fig.13.17 Block diagram of Communication system

#### 1. Information or input signal

- The communication systems have been developed for communicating useful information from one place to other
- The information can be in the form of sound signal like speech or music or it can be in the form of pictures.

#### 2. Input Transducer

- The information in the form of sound, picture or data signals cannot be transmitted as it is.
- First it has to be converted into a suitable electrical signal.



- The input transducers commonly used in the communication systems are microphones, TV etc.

### **3. Transmitter**

- The function of the transmitter block is to convert the electrical equivalent of the information to a suitable form
- It increases the power level of the signal. The power level should be increased in order to cover a large range. The transmitter consists of the electronics circuits such as amplifier, mixer, oscillator, and power amplifier.

### **4. Communication channel or medium**

- The communication channel is the medium used for the transmission of electronic signals from one place to another.
- The communication medium can be conducting wires, cables, optical fibres or free space. Depending upon the type of the communication medium, two types of the communication system will exist
  - a. Wire communication or line communication
  - b. Wireless communication or radio communication

### **5. Noise**

- Noise is an unwanted electrical signal which gets added to the transmitted signal when it is travelling towards receiver.
- Due to noise, the quality of the transmitted information will degrade. One added the noise cannot be separated out from the information
- Hence noise is a big problem in the communication systems.

### **6. Receiver**

- The reception is exactly the opposite process of transmission. The received signal is amplified and demodulated and converted in a suitable form
- The receiver consists of the electronic circuits like mixer, oscillator, detector and amplifier.

### **7. Output Transducer**

- It consists of the electrical signal at the output of the receiver back to the original form i.e. sound or TV pictures.

The typical example of the output transducers are loud speakers, picture tubes etc

## Unit summary and new words

- Communication is the process of using sounds, words, symbols, signs, pictures or signals to pass a message or information from one person to another.
- The five elements of communication system are: message source, transmitter, communication channel, and receiver and message user.
- There four commonly used bounded transmission media are: two wire open lines cables, twisted pair cables, coaxial cables and fibre optic cables.
- The two-wire open line cable is made up of two parallel copper wires separated by a plastic insulator. The insulator reduces crosstalks. The wires are highly susceptible to noise and electromagnetic field.
- A twisted pair cable is made up of two solid copper wires twisted around each other in a double helix manner. The twisting reduces the build up of electromagnetic field. There are two categories of coaxial cables: the unshielded twisted pair (UTP) and shielded twisted pair (STP). The UTP cable pairs has a shield that further prevents electromagnetic interference (EMI) from the environment.
- Coaxial cable has a copper core (coax) which may be of solid copper wire surrounded by a dielectric material. The dielectric material is then surrounded by mesh conductor which is covered by a shield making the cable more resistant to electromagnetic interference. There are two categories of coaxial cables: thinnet and thicknet
- The fibre optic cable is made up of the core, cladding, buffer, strength members and the jacket. The data signal travels as light through the core, due to total internal reflection.
- Examples of wireless communication are microwave, radio waves, infrared, satellite and bluetooth communications

## Unit Test 13

### Part A: Select the most appropriate answer from the choices given.

1. One of the following is relatively cheap and suffers from crosstalk. Which one?
  - A. Two wire open lines
  - B. Coaxial cable
  - C. Fiber Optic cable
2. To avoid crosstalk, UTP cables are:
  - A. Insulated with a thick casing
  - B. Shielded with a braided wire
  - C. Pairs are twisted at a certain pitch
3. The following statements best describes a coaxial cable:
  - A. A pair of copper wires twisted together; cheap; readily available.
  - B. Have low attenuation; uses light signals to transmit messages.
  - C. Has single central core surrounded by dielectric material, aluminium foil and braided shield.
4. One of the following cables has a dielectric insulators around the core
  - A. Coaxial
  - B. Multimode fibre
5. Fibre optic cables transmit light using the following concept:
  - A. Total internal reflection caused by refraction at the critical angle.
  - B. Total internal refraction caused by reflection at the critical angle.
  - C. Total internal reflection caused by logical mirrors at the critical angle.
6. Which one of the following show the correct sequence of sending a message via a satellite transmission system:
  - A. Source, base station, downlink, satellite, uplink, base station, destination
  - B. Source, base station, uplink, satellite, downlink, base station, destination
7. What name is given to the surface area on earth where a satellites signal can be received.
  - A. Satellites shadow
  - B. Satellites footprint
  - C. Satellites beam.
8. Radio waves travel in a \_\_\_\_\_ manner from source to destination while microwaves do the same in a \_\_\_\_\_ manner respectively.
  - A. Unidirectional, omnidirectional
  - B. Singledirectional, multidirectional
  - C. Omnidirectional, unidirectional

9. The following types of radio waves are suitable for over the horizon transmission:
  - A. High frequency (HF)
  - B. Ultra-High frequency (UHF)
  - C. Very High frequency (VHF)
10. A student realised that a phone could be linked to a computer wirelessly to transfer photo's from the phones memory to the computer and vice versa within a limited distance of a few meters. What technologies could be used to achieve this phenomena?
  - A. Bluetooth and infrared transmission.
  - B. VHF and UHF transmission.
  - C. Microwave transmission.
11. Which cable would you recommend for use in the following networking environments:
  - A. In a petrol handling terminal.
  - B. In a busy office LAN.
  - C. A campus backbone.
  - D. Setting up an undersea marine cable.
  - E. In an electrically noisy environment.
  - F. To carry video and sound for cable TV or CCTV system.
  - G. Telephone system trunching.

**Part B: Fill in the gaps.**

12. The \_\_\_\_\_ cable is made up of parallel insulated copper wires.
13. Twisting of UTP cables is meant to reduce \_\_\_\_\_ between cables that are close to each other.
14. The \_\_\_\_\_ fiber is preferred for long distance backbones while the \_\_\_\_\_ is used for short distance backbones.
15. Repeater stations are constructed on raised ground in order to maintain a \_\_\_\_\_ with one another.
16. \_\_\_\_\_ have a limited range of about 10m radius, cannot penetrate surfaces and can be used to wirelessly connect computers to peripheral devices.
17. \_\_\_\_\_ have a limited range of about 300m radius, can penetrate surfaces and can be used to wirelessly connect computers to peripheral devices or mobile devices.

18. The range within which computing devices can wirelessly connect to a wired network for internet access is called \_\_\_\_\_.
19. Explain the following statement: “. . *radio waves are omnidirectional while microwaves are unidirectional* . .”
20. Describe the factors that are driving more and more people to set up wireless networks.

**Part C: Write a brief correct response.**

21. State two differences between single mode and multimode fibre optic cable.
22. If you wanted to link networks separated by long distance, what fibre optic cable would you select and why?
23. Describe waves available in electromagnetic spectrum.
24. What type of radio communication relies on the earth's ionosphere?
25. Differentiate between single mode and multimode fibre cables.
26. Explain the importance of the wire mesh in a coaxial cable.
27. Explain the line of sight principle in infrared transmission.

## Properties of physical processes affecting plant growth

### Key Unit Competence

By the end of this unit the learner should be able to describe the physical properties affecting plant growth.

### Learning objectives

#### Knowledge and understanding

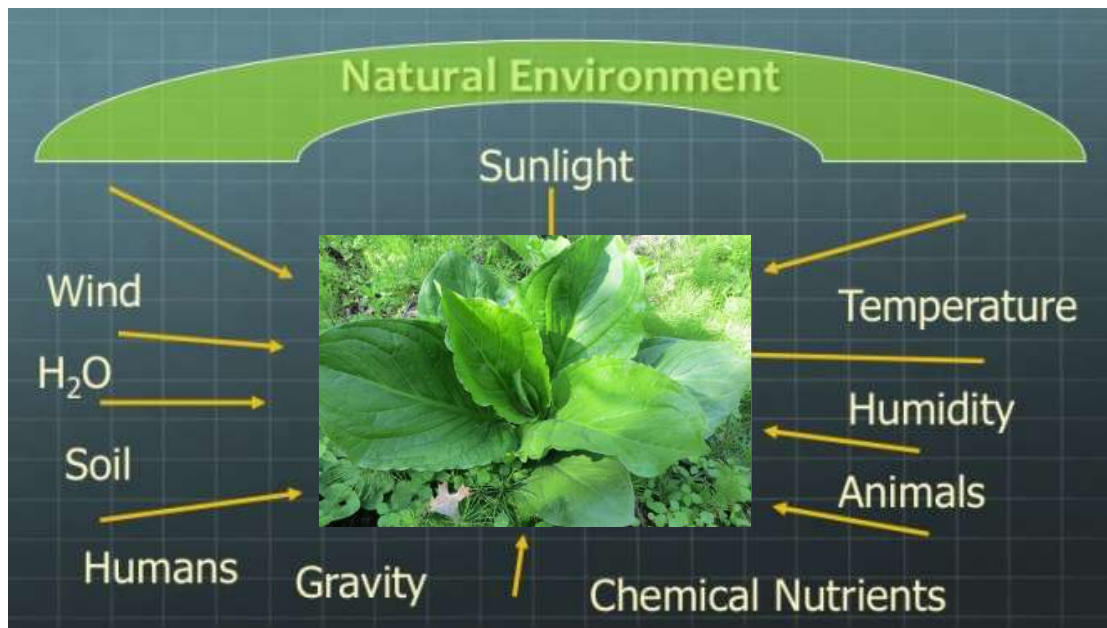
- Explain environmental factors.
- Explain composition of the atmosphere, soil aeration, soil structure and soil reaction,
- Explain Biotic factors, and mineral supply.
- Describe impact of environmental factors on range plant productivity, water, temperature, light, atmosphere, nutrients, fire and grazers.
- Describe physical properties of soil (soil structure and texture) and their application on plant nutrition and plant growth.

#### Skills

- Explain aspects of physics in physical processes affecting the environment.
- Apply knowledge of physics to explain factors affecting plant growth.
- Identify physical properties of soil (soil structure and texture) and describe their relation to plant nutrition and plant growth.

#### Attitude and value

- Appreciate the need to think scientifically, and evaluate environmental factors that affects plant growth.
- Appreciate the benefits of mineral elements (cobalt, vanadium, sodium, silicon, selenium) to plants.
- Adapting scientific method of reasoning about the environment.



## Introduction

### Unit Focus Activity

1. Discuss and make presentation on environmental factors: Temperature, moisture supply, radiant energy, composition of the atmosphere, soil aeration and soil structure, soil reaction, biotic factors, supply of mineral nutrients.
2. In your view, how do temperature, radiant energy and moisture supply affect plant growth?
3. Name other examples of factors that can affect plant growth.
4. What are biotic factors? How do they affect plant growth?
5. From the above discussed factors, discuss and make debate on the impact of selected environmental factors on range plant productivity: water, temperature, light, atmosphere, nutrients, fire and grazers.
6. Discuss and make presentation on physical properties of soil (soil structure and texture) and their role in plant nutrition and plant growth.
7. A research from Internet literature on environment protection and note down your findings.
8. Read your findings to the class.

## 14.1 Environmental factors and their impact on plant growth

### Activity 14.1

To find out environmental factors that affect plant growth

#### Materials

Internet articles on environmental factors affecting plant growth.  
Reference books

#### Steps

1. Do a research from the internet and reference materials meaning of environmental factors and name some factors.
2. In your view, how do temperature, radiant energy and moisture supply affect plant growth?
3. Name other examples of factors that can affect plant growth.
4. Note down your findings in your note books.
5. Share your findings with your friend and then with the whole class
6. Discuss your findings as the whole class with the help of the teacher and note them down in your notebooks.

**Environmental (abiotic) factors** are all external conditions and influences affecting the life and development of an organism. It is important to understand the environmental aspects that affect plant growth because plant growth and distribution are limited by these environmental factors. The following are the most important environmental factors;

- Radiant energy
- Moisture supply
- Soil aeration and soil structure
- Supply of mineral nutrient
- Temperature
- Composition of the atmosphere
- Soil reaction
- Absence of growth-restricting substances

### 14.1.1 Light (Radiant Energy)

#### Activity 14.2

To discuss how light affects, plant growth

#### Materials

- Internet articles
- reference books

#### Steps

1. Conduct a research on the definition of light and how it is useful to plant growth.
2. Note down your findings in your note books.



3. Share your findings with your friend and then to the whole class
4. Discuss your findings as the whole class with the help of the teacher and note them down in your notebooks.

There are three aspects of light that affect plant growth. These are quantity, quality, and duration.

Light quantity is the intensity or concentration of sunlight and varies with the period of the year. We experience the maximum in the summer and the minimum in winter. The more sunlight a plant receives (up to a point), the more food it produces through photosynthesis. As the sunlight quantity decreases the photosynthetic process decreases and vice versa. Light quantity can be decreased in a garden or greenhouse by using shade-cloth or shading paint above the plants. It can be increased by surrounding plants with white or reflective material or supplemental lights.

Light quality is the color or wavelength reaching the plant surface. Sunlight can be broken up by a prism into respective colors of red, orange, yellow, green, blue, indigo, and violet. Red and blue light have the greatest effect on plant growth. Green light is least effective to plants as most plants reflect green light and absorb very little. It is this reflected light that makes them appear green. Blue light is primarily responsible for vegetative growth or leaf growth. Red light when combined with blue light promotes flowering. Fluorescent or cool-white light is high in the blue range of light quality and is used to encourage leafy growth. These lights are excellent for starting seedlings.

Light duration or photoperiod refers to the amount of time that a plant is exposed to sunlight. The length of uninterrupted dark periods is critical to floral development. The ability of many plants to flower is controlled by photoperiod.

### Exercise 14.1

**For the following questions, select the most appropriate answers.**

1. The following characteristics of light that affect plant growth except
  - A. Light quality
  - B. Light quantity
  - C. Light duration
  - D. Refraction of light
2. Light duration in plant growth refers to
  - A. The amount of time that a plant is exposed to sunlight.
  - B. Intervals between light bright and dull lights
  - C. Color of light
  - D. The intensity of light

3. Light quality refers to
  - A. The color or wavelength reaching the plants surface
  - B. The amount of time plants are exposed to light
  - C. Color of light
  - D. The intensity of light
4. Light quantity refers to
  - A. Wave length reaching the plant
  - B. The intensity or concentration of sunlight
  - C. Color of light
  - D. The amount of time plants receive light
5. Light affects plant growth except
  - A. Dominance
  - B. Light quantity
  - C. Light duration
  - D. Light quality

### 14.1.2 Temperature

#### Activity 14.3

To discuss the effects of temperature on plant growth

#### Materials

- Reference materials or resource persons

#### Steps

1. From the knowledge of physics, define temperature.
2. Research from biology, agriculture and geography the aspects of plant growth that temperature affects directly.
3. Note down your findings in your note books.
4. Share your findings with your friend and then with the whole class
5. Discuss your findings as the whole class with the help of the teacher and note them down in your notebooks.

Temperature is the degree of hotness or coldness of a body. It is measured using a thermometer. It's also a measure of how fast the atoms and molecules of a substance are moving. Temperature is measured in degrees on the Fahrenheit, Celsius scales. On the Kelvin scale it is measured in kelvins

Temperature directly affects the following on plant growth;

- Photosynthesis

- Flowering
- Transpiration
- Respiration
- Sugar storage; Low temperatures reduce energy use and increase sugar storage
- Dormancy: there is breakage of dormancy if warmth comes after a period of low temperature and it will make plants to resume active growth.
- Absorption of water and nutrients

The rate of these processes increases with an increase in temperature. Responses are different with different crops. Temperature also affects soil organisms. Nitrifying bacteria is inhibited by low temperature. pH may decrease in summer due to activities of microorganisms.

High temperatures cause increased respiration sometimes above the rate of photosynthesis. This means that the products of photosynthesis are being used more rapidly than they are being produced. For growth to occur photosynthesis must be greater than respiration

Low temperatures can result in poor growth. Photosynthesis slows at low temperatures. Since photosynthesis is slowed, growth is slowed and this results in lower yields. Not all plants grow best in the same temperature range.

As temperature is also the measure of the intensity of heat, soil micro-organisms show maximum growth and activity at optimum soil temperature range. The biological processes for nutrient transformations and nutrient availability are controlled by soil temperature and soil moisture. Soil temperature has a profound influence on seed germination, root and shoot growth, and nutrient uptake and crop growth. Seeds do not germinate below or above a certain range of temperature but micro-organisms functioning in the soil are very active while a certain range of temperature, which is about 27°C to 32°C. It is necessary to know whether the soil temperature is helpful to the activities of plants and micro-organisms so that it could be suitably controlled and modified. The various factors that control the soil temperature are soil moisture, soil color, slope of the land, vegetative cover and general soil tilth. Aeration can be used to control soil temperature, regulate soil moisture, improve drainage, stimulate microbial activity and improve overall soil tilth.

### **Exercise 14.2**

1. Explain how temperature can be controlled in the soil.
2. Explain what temperature effects on plant growth directly.

### 14.1.3 Moisture Supply (Humidity)

#### Activity 14.4

To discuss how moisture supply affects plant growth

#### Materials

- Science encyclopedia or • Internet articles

#### Steps

1. Conduct a research from the internet and reference books on the meaning of moisture.
2. Discuss how it affects plant growth as an environmental factor.
3. Note down your findings in your note books.
4. Share your findings with your friend and then with to the whole class
5. Discuss your findings as the whole class with the help of the teacher and note them down in your notebooks.

Soil moisture refers to the amount of water present or the presence of water, in trace amounts in the soil. Plant growth is restricted by low and high levels of soil moisture. Good soil moisture improves nutrient uptake.

Water is a primary component of photosynthesis. Water also provides the pressure to move a root through the soil. Among water's most critical roles is that of a solvent for minerals moving into the plant and for carbohydrates moving to their site of use or storage. By its gradual evaporation, water from the surface of the leaf, near the stomata, helps stabilize plant temperature.

Warm air can hold more water vapor than cold air. If the amount of water in the air stays the same and the temperature increases the relative humidity decreases. Water vapor will move from an area of high relative humidity to one of low relative humidity. The greater the difference in humidity the faster water will move.

#### Self-check

Explain the importance of moisture to plant life

## 14.1.4 Supply of mineral nutrients

### Activity 14.5

To find out how the supply of mineral nutrients affects the plant growth

#### Materials

- Science encyclopedia or Internet articles

#### Steps

1. Conduct a research from the internet and reference books about the supply of mineral nutrients and how they can affect the growth of a plant.
2. In your research, name some mineral nutrients that are needed by a plant.
3. Note down your findings in your note books.
4. Share your findings with your friend and then with the whole class
5. Discuss your findings as the whole class with the help of the teacher and note them down in your notebooks.

Plant nutrition refers to the needs and uses of the basic chemical elements in the plant. Nutrient availability affects the soil's inherent fertility and its ability to hold nutrients.

People confuse plant nutrition with plant fertilization. Fertilization is the term used when these materials are supplied to the environment around the plant.

Plant nutrients are composed of single elements (for example, phosphorus (P)) or compounds of elements (for example, ammonium nitrate ( $\text{NH}_4\text{NO}_3$ )). In either case, the nutrients are all composed of atoms.

Plants need 18 elements for normal growth. Carbon, hydrogen, and oxygen are found in air and water. Nitrogen, phosphorus, potassium, magnesium, calcium, and sulfur are found in the soil. The latter six elements are used in relatively large amounts by the plant and are called macronutrients. There are nine other elements that are used in much smaller amounts; these are called micronutrients or trace elements. The micronutrients, which are found in the soil are iron, zinc, molybdenum, nickel, manganese, boron, copper, cobalt, and chlorine. All 18 elements, both macronutrients and micronutrients are essential for plant growth.

Most of the soil nutrients that a plant takes up must be in a soluble form (in other words, mixed with water). Most of the nutrients that a plant needs are dissolved in water and then absorbed by the roots. Ninety-eight percent of these plant nutrients are absorbed from the soil solution and only about 2% are actually extracted from the soil particles by the root. Most of the nutrient elements are absorbed as charged ions or pieces of molecules. Ions may be positively charged

cations or negatively charged anions. Positive and negative are equally paired so that there is no overall charge. For example, nitrogen may be absorbed as nitrate ( $\text{NO}_3^-$ ) which is an anion with one negative charge. A potassium ion ( $\text{K}^+$ ) is a cation with one positive charge. Potassium nitrate ( $\text{KNO}_3$ ) has one potassium ion and one nitrate ion. Calcium nitrate ( $\text{Ca}(\text{NO}_3)_2$ ) has one calcium cation that has two positive charges and two negative, single charge, nitrate ions to match the two positive charges of the calcium.

Adequate water and oxygen must be available in the soil. Water is required for nutrient movement into and throughout the roots. Oxygen is required in the soil for respiration to occur to produce energy for growth and the movement of mineral ions into the root cells across their membranes. This is an active absorption process utilizing energy from respiration. Oxygen is not transported to roots from the shoot. Without adequate oxygen from the soil environment there is no energy produced for nutrient absorption. This also stops active absorption in which water flows into the cell due to the higher concentration of nutrients that were actively absorbed.

### Exercise 14.3

**Multiple choice questions 1- 4, Select the most appropriate answer.**

1. How many chemical elements are known to be important to a plants growth survival?
 

<b>A.</b> 18	<b>B.</b> 13
<b>C.</b> 3	<b>D.</b> 1
  
2. The letters NPK represent in order;
 

<b>A.</b> Nitrate, phosphoricium and potassium
<b>B.</b> Nitrogen, potassium and phosphate
<b>C.</b> Nitrogen, phosphorus and potassium
  
3. The ability of the soil to hold essential elements in the soil so plants can access them during plant growth is called \_\_\_\_\_?
 

<b>A.</b> Nutrient level
<b>B.</b> fertilization level
<b>C.</b> pH
<b>D.</b> cation exchange capacity or CEC
  
4. \_\_\_\_\_ is required for nutrient movement in plants and \_\_\_\_\_ is required for respiration to occur to produce energy throughout the roots for the growth and movement of mineral ions into the root cells across their membranes.

- A.** Humus, oxygen
- B.** Water, oxygen
- C.** Water, humus
- D.** Minerals, oxygen

5. Name five macronutrients and five micronutrients of plants

Macronutrients	Micronutrients

6. Give the nutrient name for the following elemental abbreviations;

- (a) P \_\_\_\_\_
- (b) Fe \_\_\_\_\_
- (c) Mg \_\_\_\_\_
- (d) K \_\_\_\_\_

### 14.1.5 Composition of the Earth's atmosphere

#### Activity 14.6

To describe the composition of the Earth's atmosphere

#### Materials

- Science encyclopedia • Internet articles

#### Steps

1. Conduct research on the internet and reference books about the composition of the atmosphere and how it affects plant growth and development.
2. Name the gases that are found in the atmosphere.
3. Note down your findings in your note books.
4. Share your findings with your friends and then with the whole class.
5. Discuss your findings as the whole class with the help of the teacher and note them down in your notebooks.

Scientists believe the Earth was formed about 4.5 billion years ago, and that its early atmosphere was probably created from the gases escaping from the Earth's interior. The atmosphere we have today is very different from the Earth's early atmosphere. When the planet first cooled down 4.4 billion years ago, volcanoes spewed out steam, carbon dioxide and ammonia, and it was 100 times as dense as today's atmosphere.

The atmosphere consists of many gases. The Earth's atmosphere is composed of the following molecules: nitrogen (78%), oxygen (21%), argon (1%), and then trace amounts of carbon dioxide, neon, helium, methane, krypton, hydrogen, nitrous oxide, xenon, ozone, iodine, carbon monoxide, and ammonia. Lower altitudes also have quantities of water vapor. The amount of carbon dioxide in the atmosphere is maintained through a balance between processes such as photosynthesis, respiration and combustion. But human activities are polluting the atmosphere.

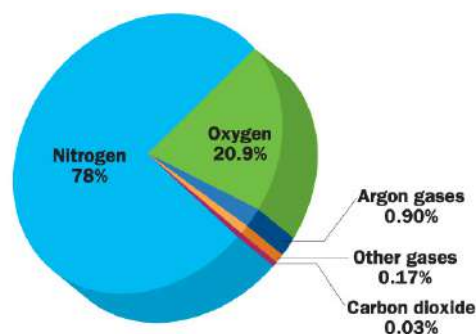


Fig. 14.1 : Composition of gases.

Photosynthesis is a key process in the evolution of the Earth's atmosphere. It is clear that the main gas is nitrogen. Oxygen - the gas that allows animals and plants to respire, and fuels to burn - is the next most abundant gas. These two gases are both elements and account for about 99% of the gases in the atmosphere. The remaining gases, such as carbon dioxide, water vapor and noble gases such as argon, are found in much smaller proportions.

The composition of the atmosphere, among other things, determines its ability to transmit sunlight and trap infrared light, leading to potentially long-term changes in climate.

## 14.1.6 Soil properties and their impacts on plant and growth

### 14.1.6.1 Soil structure and plant growth

#### Activity 14.7

To describe different types of soil

#### Materials

- Clay soil
- Silt
- Sand soil

#### Steps:

1. Collect different types of soil with the help of your teacher from different areas including swamps.
2. Get different small heaps of each type and moisten them with water.
3. Rub them between the thumb and fingers.
4. Which one is sand soil, silt and clay?
5. Outline the characteristics of each type



6. Note down your findings in your note books.
7. Share your findings with your friend and then with the whole class
8. Discuss your findings as the whole class with the help of the teacher and note them down in your notebooks.

Soil structure refers to the arrangement of soil particles into aggregates (or peds) and the distribution of pores in between them.

**Aggregates** are groups of soil particles held together by organic matter or chemical forces. The arrangement of soil aggregates into different forms gives a soil its structure. The natural processes that aid in forming aggregates are:

- (i) wetting and drying,
- (ii) freezing and thawing,
- (iii) microbial activity that aids in the decay of organic matter,
- (iv) activity of roots and soil animals, and
- (v) absorbed cations.

The wetting/drying and freezing/thawing action as well as root or animal activity push particles back and forth to form aggregates. Decaying plant residues and microbial by-products coat soil particles and bind particles into aggregates. Absorbed cations help form aggregates whenever a cation is bonded to two or more particles.

Aggregates are described by their shape, size and stability. Aggregate types are used most frequently when discussing structure ( Fig 14.1 and Table 14.1).

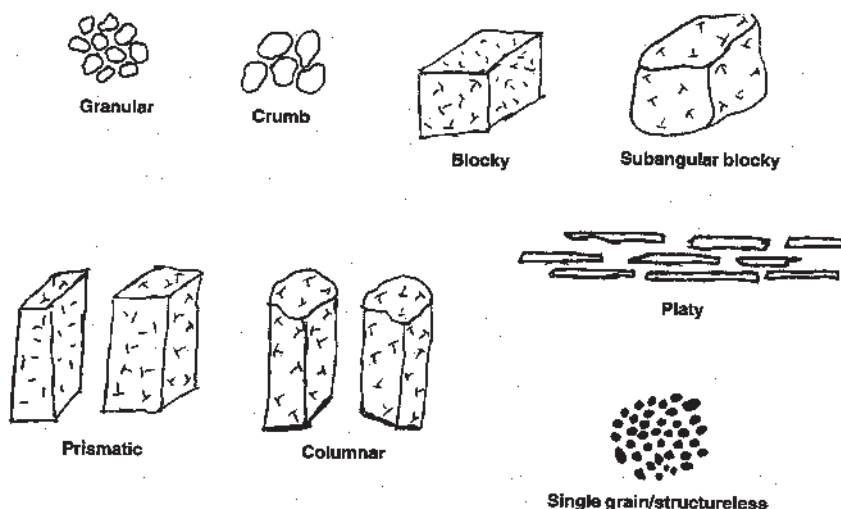


Fig. 14.2 : Soil structural types.

Table 14.1 Structure type and description

Type	Description
Granular	Rounded surface
Crumb	Rounded surfaces but larger than granular
Subangular blocky	Cube-like with flattened surfaces and rounded corners
Blocky	Cube-like with flattened surfaces and sharp corners
Prismatic	Rectangular with a long vertical dimension and flattened top
Columnar	Rectangular with a long vertical dimension and rounded top
Platy	Rectangular with a long vertical horizontal dimension
Single grain	No aggregation of coarse particles when dry
Structureless	No aggregation of fine particles when dry

Water movement and drainage are poor in soils having blocky, prismatic, columnar and platy structures. These structured soils especially the platy type are most suitable for aquaculture.

**Soil structure** is defined in terms of grade, class and type of aggregates.

**Grade:** is the degree of aggregation and expresses the differential between cohesion within aggregates and adhesion between aggregates.

**Class:** The class of structure describes the average size of individual aggregates.

**Type:** describes their form or shape. The various class divisions are: very fine or very thin, fine or thin, medium, coarse or thick and very coarse or very thick.

The spaces in the soil are called **pores**. The pores between the aggregates are usually large (macro-pores), and their large size allows good aeration, rapid infiltration of water, easy plant root penetration, and good water drainage, as well as providing good conditions for soil micro-organisms to thrive. The smaller pores within the aggregates or between soil particles (micropores) hold water against gravity (capillary action) but not necessarily so tightly that plants cannot extract the water.

A well-structured soil forms stable aggregates (aggregates that don't fall apart easily) and has many pores (Figure 3.6a). A well-structured soil is friable, easily worked and allows germinating seedlings to emerge and to quickly establish a strong root system.

A poorly structured soil has either few or unstable (readily broken apart) aggregates

and few pore spaces. A poorly structured soil can result in unproductive compacted or waterlogged soils that have poor drainage and aeration. Poorly structured soil is also more likely to slake and to become eroded.

### **Importance of soil structure plant growth**

- Reduced erosion due to greater soil aggregate strength and decreased overland flow
- Improved root penetration and access to soil moisture and nutrients
- Retention and availability due to improved porosity.
- Increases infiltration of water, thus reducing runoff and erosion and increases the amount of plant available water.
- Improves seedling emergence due to reduced crusting of the surface
- Large continuous pores increase permeability.

### **Maintaining soil structure**

- Growth of legumes will also give the soil more microorganisms which give certain beneficial fungi which will stabilize peds.
- plant cover crops in fall and winter
- plant more grasses
- turn under crop residue
- Add manure.
- Till soil only at the proper moisture contents. Never till when the soil is too wet. This will cause the soil to become cloddy. Aggregates are easily destroyed.
- Add the proper amounts of lime and fertilizer. Proper plant growth will lead to the development of good soil structure.
- Grow grasses and legumes. These plants may help form unstable aggregates and their organic matter will help stabilize the aggregate.

### **Exercise 14.4**

**For questions 1 - 5, select the most appropriate answer from the choices given.**

1. An ideal soil should contain \_\_\_\_\_?  
**A.** Equivalent portions of sand, silt, clay and organic matter  
**B.** Mostly clay  
**C.** Mostly sand  
**D.** Don't know

2. Soil structure is \_\_\_\_?
  - A. Perforating the soil with small holes to allow air circulation, water and nutrients to penetrate the grass roots
  - B. Arrangement of soil particles and pores in the soil and ability of particles to form aggregates
  - C. The strength of the acidity or alkalinity of soil
  - D. An activity of a living organism that affects another living organism within its environment
3. The following are the natural processes that aid in the formation of aggregates apart from
  - A. Wetting and drying
  - B. Activity of roots and animals
  - C. Freezing and thawing
  - D. Soil structure
4. \_\_\_\_\_ is not a way of maintaining a good soil structure
  - A. Add manure
  - B. Plant more grasses
  - C. Add the proper amounts of lime and fertilizer
  - D. Till when the soil is too wet
5. Pores are \_\_\_\_?
  - A. Degree of aggregation
  - B. Average size of individual aggregates
  - C. Spaces in the soil
  - D. Class of soil
6. Discuss ways of maintaining a good soil structure for a long period of time for better growth and development of plant life.
7. Explain the importance of soil structure for the growth of plants.
8. Discuss the difference between a well structure soil and a poorly structured soil to plant growth and development.
9. Define soil structure and aggregation.

#### 14.1.6.2 Soil aeration

##### Activity 14.8

##### To compare aeration in different soils

##### Materials

Sand soil, clay soil, water and two beakers

##### Steps:

1. Put sand and clay soils in two different beakers.
2. In each type of soil put some water and observe what happens. Which soil gives out most air bubbles? Explain why.

2. Discuss with your partner what soil aeration means
3. Describe why soil aeration is important to plant growth and development
4. Share your findings with your friend and then with the whole class

Aeration involves perforating the soil with small holes to allow air circulation, water and nutrients to penetrate the grass roots. This helps the roots grow deeply and produce a stronger, more vigorous lawn. The main reason for aerating is to alleviate soil compaction.

Compact soils of high bulk density and poor structure are poorly aerated.

Pore space is occupied by air and water so the amount of air and water are inversely proportional to the amount of oxygen in the soil. On well drained soils, oxygen content is not likely to be limiting to plant growth.

Plants vary widely in their sensitivity to soil oxygen. Oxygen is required by microbe and plants for respiration. Oxygen taken up and carbon dioxide evolved are stoichiometric. Under anaerobic conditions, gaseous carbon compounds other than carbon dioxide are evolved. Root elongation is particularly sensitive to aeration. Oxygen deficiency disturbs metabolic processes in plants, resulting in the accumulation of toxic substances in plants and low uptake of nutrients.

### Importance of soil aeration

1. **Plant and root growth:** Soil aeration is an important factor in the normal growth of plants. The supply of oxygen to roots in adequate quantities and the removal of CO<sub>2</sub> from the soil atmosphere are very essential for healthy plant growth.

When the supply of oxygen is inadequate, the plant growth either retards or ceases completely as the accumulated CO<sub>2</sub> hampers the growth of plant roots. The abnormal effect of insufficient aeration on root development is most noticeable on the root crops. Abnormally shaped roots of these plants are common on the compact and poorly aerated soils. The penetration and development of root are poor. Such undeveloped root system cannot absorb sufficient moisture and nutrients from the soil

2. **Microorganism population and activity:** The microorganisms living in the soil also require oxygen for respiration and metabolism. Some of the important microbial activities such as the decomposition of organic matter, nitrification, Sulphur oxidation etc depend upon oxygen present in the soil air. The deficiency of air (oxygen) in soil slows down the rate of microbial activity.

For example, the decomposition of organic matter is retarded and nitrification arrested. The microorganism population is also drastically affected by poor aeration.

- 3. Formation of toxic material:** Poor aeration results in the development of toxins and other injurious substances such as ferrous oxide,  $H_2S$  gas,  $CO_2$  gas etc. in the soil.
- 4. Water and nutrient absorption:** A deficiency of oxygen has been found to check the nutrient and water absorption by plants. The energy of respiration is utilized in absorption of water and nutrients. Under poor aeration condition (this condition may arise when soil is water logged), plants exhibit water and nutrient deficiency
- 5. Development of plant diseases:** Insufficient aeration of the soil also leads to the development of diseases. For example, wilt of gram and dieback of citrus and peach.

### Exercise 14.5

**For questions 1 - 5, select the most appropriate response from the choices given.**

- This constituent gives the highest aeration quality to a soil.  
**A.** Silt                      **B.** Sand      **C.** clay
- Which gas allows the respiration of microorganisms living in the soil?  
**A.** Sulphur dioxide                      **B.** Nitrogen  
**C.** Oxygen                                  **D.** Hydrogen sulphide
- Oxygen deficiency disturbs metabolic processes and results in accumulation of toxic substances in plants apart from?  
**A.** Ferrous oxide                      **B.** Hydrogen sulphide  
**C.** Carbon dioxide                      **D.** neon
- Which one of the following is a disadvantage of poor soil aeration  
**A.** development of plant diseases      **B.** competition for food  
**C.** improved root penetration              **D.** reduces erosion
- soil aeration is \_\_\_\_\_?  
**A.** Perforating the soil with small holes to allow air circulation, water and nutrients to penetrate the grass roots  
**B.** Arrangement of soil particles into aggregates  
**C.** The strength of the acidity or alkalinity of soil  
**D.** An activity of a living organism that affects another living organism within its environment.
- Discuss the importance of soil aeration to plant life

### 14.1.6.3 Soil texture

**Soil texture** is the relative distribution of the different sized particles in the soil. It is determined by the proportions of sand, silt, and clay in the soil. Soil texture can also refer to the relative proportions of particles of various sizes such as sand, silt and clay in the soil. It is a stable property of soils and, hence, is used in soil classification and description.

Each **soil separate** represents a distinct physical size group.

The term soil separate refers to a specific size of a particle and not the composition of that particle. However, certain minerals will tend to dominate or make up the various separates.

Sands: generally made up of quartz

Silts: commonly composed of quartz and feldspars

Clays: secondary minerals, clay minerals, and Fe oxides

The organic matter is not a part of the soil's texture.

When they are wet, sandy soils feel gritty, silt soils feel smooth and silky, and clayey soils feel sticky and plastic, or capable of being moulded. Soils with a high proportion of sand are referred to as 'light', and those with a high proportion of clay are referred to as 'heavy'.

The names of **soil texture classes** are intended to give you an idea of their textural make-up and physical properties. The three basic groups of texture classes are sands, clays and loams.

A soil in the **sand group** contains at least 70% by weight of sand. A soil in the **clay group** must contain at least 35% clay and, in most cases, not less than 40%. A **loam soil** is, ideally, a mixture of sand, silt and clay particles that exhibit light and heavy properties in about equal proportions, so a soil in the loam group will start from this point and then include greater or lesser amounts of sand, silt or clay.

Additional texture class names are based on these three basic groups. The basic group name always comes last in the class name. Thus, loamy sand is in the sand group, and sandy loam is in the loam group.

Soil texture influences many soil physical properties, such as water-holding capacity and water infiltration rates. Coarse-textured sandy soils generally have high infiltration rates but poor water-holding capacity, whereas a fine-textured clay soil generally has a low infiltration rate but a good water-holding capacity.

Soil texture also influences the soil's inherent fertility. More nutrients can be absorbed by a gram of clay particles than by a gram of sand or silt particles, because the clay particles provide a much greater surface area for absorption.

### Exercise 14.6

**For the questions 1 - 10, choose the most appropriate answer.**

- Soil with a high water holding capacity has a texture which is
  - Spongy and loose
  - Gritty and granular
  - Wet and muddy
  - Clay-like and dense
- Nsengimana is studying different types of soil. He is comparing clay, loam, sand and silt. Which soil will Nsengimana find to be made of the largest particles?
  - Clay
  - Loam
  - Sand
  - silt
- What determines the texture of the different kinds of soil?
  - The size of the grains and the amount of space between grains.
  - Texture depends on what kinds of crops have been grown in the soil.
  - Soil texture is determined by the kind of rock that lies underneath the soil.
  - Texture depends on the age of the soil, older soil is much finer than new soil.
- If Mutoni wanted to buy two thousand acres of land to use as farmland, what kind of soil should she look for?
  - Clay
  - humus
  - Loam
  - sandy
- Which is the largest particle size found in soil?
  - Gravel
  - Clay
  - Silt
  - sand
- How could you test a soil texture?
  - Sift it
  - Smell it
  - Add water to it
  - Add plants to it
- Kirezi dug her hands into the soil of her garden and found an earth worm, a few plants roots, a beetle, and a spider mixed in with the soil. Why are all these organisms important to kirezi's garden?
  - The soil is too cold for the organisms
  - The soil is mostly made of sand
  - They destroy the vegetables in the garden
  - They recycle energy and nutrients in the soil



8. What type of soil would Nshozamihigo use if he wants to grow plant that needs a lot of water
- A. Sandy soil
  - B. Dark soil that has clay in it
  - C. Rocky soil made of pebbles
  - D. Salty soil made of silt
9. Why is fertile soil the best soil for growing crops?
- A. It is lighter in color and can absorb more sunlight
  - B. It has more fresh water
  - C. It has more salt water
  - D. It is rich with minerals and matter from dead organisms
10. Which type of soil would retain the most water?
- A. Sand
  - B. Silt
  - C. Loam
  - D. Clay
11. In Fig. 14.3, match the following characteristics to the specific soil types.

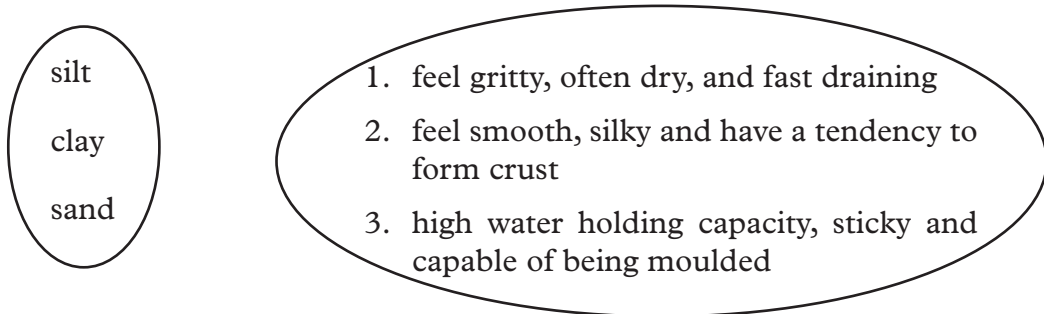


Fig. 14.3

#### 14.1.6.4 Soil reaction

Soil pH or reaction is a measure of the concentration hydrogen ion concentration. Soil pH or soil reaction is an indication of the acidity or alkalinity of soil and is measured in pH units.

The pH scale goes from 0 to 14 with pH 7 as the neutral point. As the amount of hydrogen ions in the soil increases the soil pH decreases thus becoming more acidic. From pH 7 to 0 the soil is increasingly more acidic and from pH 7 to 14 the soil is increasingly more alkaline or basic.

#### Effects of soil reaction on plant growth

- (i) The effect of soil pH is great on the solubility of minerals or nutrients. Fourteen of the seventeen essential plant nutrients are obtained from the

soil. Before a nutrient can be used by plants it must be dissolved in the soil solution. Most minerals and nutrients are more soluble or available in acid soils than in neutral or slightly alkaline soils. A pH range of approximately 6 to 7 promotes the most ready availability of plant nutrients.

- (ii) The soil pH can also influence plant growth by its effect on activity of beneficial microorganisms. Bacteria that decompose soil organic matter are hindered in strong acid soils. This prevents organic matter from breaking down, resulting in an accumulation of organic matter and the tie up of nutrients, particularly nitrogen, that are held in the organic matter.

### Exercise 14.7

For the following questions, choose the most correct answer

- Which of the following pH values represents the most acid condition?  
A. 1.0                      B. 5.55                      C. 7.0  
D. 10                        E. 100
- Hydroxyl ion concentration is greatest in a soil solution with a pH a value of?  
A. 10                              B. 4.0  
C. 5.0                              D. 6.5
- A measure of the acidity or alkalinity of the soil is called?  
A. Leaching                      B. A Soil test  
C. Soil pH                        D. Don't know
- An acid soil will have a pH \_\_\_\_\_ while alkaline soil will have a pH \_\_\_\_\_  
A. Above 7.0 below 7.0      B. Below 7.0, above 7.0  
C. Above 1.2, below 13.5    D. None of the above
- Aluminium sulphate is used to make the soil pH  
A. More alkaline                B. More basic  
C. More nutrient rich        D. More acidic

## 14.2 Biotic factors

### Activity 14.9

To find out what a biotic factors are

#### Materials

- Reference books or Internet

## Steps

1. Conduct research from the internet and reference books about biotic factors and abiotic factors
2. In your research, name and explain some biotic and abiotic factors.
3. From the knowledge of biology, define an ecosystem.
4. Note down your findings in your note books.
5. Share your findings with your friend and then to the whole class
6. Discuss your findings as the whole class with the help of the teacher and note them down in your notebooks.

Biotic factors refer to the living organisms, both plants and animals and the activities they do that influence plant growth.

The effects of these living factors on plant may be advantageous or disadvantageous, depending on how they interact with the plant.

### ***Examples of Biotic Factors and their effects on plant growth:***

**Mutualism** : is a species-to-species interaction in which both the biotic factor and the plant benefit by the relationship.

Example of mutualism between plants and other organisms include:

The symbiotic relationship the Rhizobium bacteria and leguminous plants. In which The bacteria live and obtain the supplies of energy in the roots of the plant and in exchange, it fixes atmospheric nitrogen into the plant

Role of insects, birds and a number of animals as agents of their pollination as they feed on nectar and leaves on plants.

Role of animals in the dispersal of fruits and seeds: Many animals, such as birds, bats, monkeys, act as important agents for disseminating the seeds, fruits and spores and thus they play important role in the migration of plant

**Herbivory**: plant-eating organisms called herbivore, such as ruminant animals, rodents, insects, and molluscs feed on plant parts. This damage to the plant ranging from death of the entire plant or organs, reduced root, stem, leaf mass, total defoliation, bores and holes on plant parts

**Parasitism**: is an interaction between two organisms in which one organism, called parasite, is benefited but causes harm to another, called host. Parasites retards the growth of plants by consuming the food and minerals in the plants. Some parasites such as fungi, bacteria and virus causing diseases to the plants.

**Competition:** Plants compete with one another for light, water and essential minerals. For this reason, some plants in the forest grow thin and tall as they seek light while others develop fibrous roots to tap the limited water.

**Human activities:** Man affect plant growth through such activities like improved cultivation methods, deforestation, causing fires and pollution

**Exercise 14.8**

**For questions 1 -5, select the most appropriate answer**

- 1. What is a biotic factor?
  - A.** Something in an ecosystem that is non living
  - B.** Something in an ecosystem that is living
  - C.** All the above
- 2. Abiotic factors are living things in an ecosystem
  - A.** True
  - B.** False
- 3. Which is a biotic
  - A.** A lake
  - B.** The air
  - C.** A tree
- 4. Temperature, light, air water, soil and climate are all \_\_\_\_\_ parts of the environment
  - A.** Biotic
  - B.** Abiotic
  - C.** Living
  - D.** boreal
- 5. What is an ecosystem?
  - A.** All the interacting organisms that live in an environment and the abiotic parts of the environment that affects the organisms
  - B.** A person who observes and studies the interactions between the biotic and abiotic parts of the environment
  - C.** The relationship among the biotic parts of the environment
  - D.** The relationship between all the biotic elements of a pond

6. Categorise the following factors as biotic of abiotic:

salt concentration, herbivory, sunlight, diseases, soil pH water depth, rain, wind, temperature, attitude, pollution, parasitism, competition for food.

Biotic factors	Abiotic factors

## Unit summary and new words

**Environmental (abiotic) factors** are all external conditions and influences affecting the life and development of an organism. Examples of environmental factors include light, temperature, moisture supply and composition of the atmosphere etc.

- Light; is factor that influences photosynthesis, phototropism, abscission, mineral absorption, photo morphogenesis, translocation, and stomata movement.
- Temperature influences plant growth processes such as respiration, transpiration, seed germination, protein synthesis, breaking of seed dormancy, and photosynthesis.
- Moisture supply(relative humidity); moisture supply affects the opening and closing of the stomata.
- Composition of the atmosphere; oxygen and carbon dioxide in the air are of particular importance to the physiology of plants i.e. Oxygen is essential in respiration for the production of energy and carbon dioxide is a raw material in photosynthesis.
- Soil structure refers to the arrangement of soil particles into aggregates (or peds) and the distribution of forces in between.
- Soil aeration is the process perforating the soil with small holes to allow air circulation, water and nutrients to penetrate the grass roots.
- Soil texture is the relative distribution of the different sized particles in the soil.
- Biotic factors refer to the living organisms, both plants and animals and the activities they do that influence plant growth. Such factors include mutualism, parasitism, competition and human activities.

## Unit Test 14

**For questions 1 - 20, select the most appropriate response from the options given**

1. What does biotic mean?  
**A.** The same thing as antibiotic      **B.** Mammal-like  
**C.** Plant-like      **D.** Living  
**E.** nonliving

2. What will happen to a plant left in the dark?
  - A. It will grow green and healthy
  - B. It will turn yellow and spindly
  - C. It will go to sleep
3. What will happen to a plant that is left un-watered?
  - A. It will move to where there is water
  - B. It will grow well and healthy
  - C. It will wilt and eventually die
4. Which three things do plants need to make food?
  - A. Water, heat, oxygen
  - B. Water, carbon dioxide, sunlight.
  - C. Water, sugar, air
5. The more water a plant is given, the better it will grow. Is this statement true or false?
  - A. True
  - B. False
  - C. It is impossible to say
6. The warmth a plant is given, the better it will grow. Is this statement true or false?
  - A. True
  - B. False
  - C. It is impossible to say
7. Grass doesn't grow as quickly during the winter as it does during the summer. What could be a reason for this?
  - A. It is colder in the winter
  - B. It doesn't rain as much in the winter
  - C. The grass is sulking
8. What job does the stem doesn't do for the plant?
  - A. Breathes for the plant
  - B. Holds the plant upright
  - C. Carries water and minerals up to the leaves
9. Why would keeping one plant in a fridge and one on a windowsill not be a fair test of how temperature affects the growth of plants?
  - A. Because it will be cold and dark in the fridge
  - B. Because the plant in the fridge will have access to food
  - C. Because the temperature will be the same in both positions

10. What part makes food for the plant?
  - A. Roots
  - B. Petals
  - C. leaves
11. Sandy soils are more easily compacted than clay soils.
  - A. True
  - B. False
12. Soil is made up of?
  - A. Mineral matter
  - B. Organic matter
  - C. Air
  - D. Water
  - E. All the above
13. An ideal garden soil is?
  - A. Fertile
  - B. Well drained
  - C. Fairly high in organic matter
  - D. All the above
14. Poor drainage in clay soils is probably the most common soil problem which causes difficulty in growing plants.
  - A. True
  - B. false
15. The four principle components of soil are \_\_\_\_\_?
  - A. Colloids, water, oxygen and compost
  - B. Air, water, minerals and organic matter
  - C. Sand, rocks, organic matter and air
16. The three textural classes of soil are?
  - A. Sand, silt, and clay
  - B. Water, minerals and air
  - C. Organic matter, loam and subsoil strata
  - D. Grass clippings, rhizomes and runners
17. \_\_\_\_\_ is the area in the soil that water is stored so plants can absorb it.
  - A. Pockets
  - B. Water table
  - C. Pore space
  - D. Tube area

- 18.** Soil texture and soil structure are important in plant growth because they influence the amount of air and water available to plants.
- A.** True
  - B.** False
- 19.** \_\_\_\_\_ soils hold relatively small amounts of water because their large pore spaces allow water to drain and \_\_\_\_\_ soils hold relatively large amounts of water due to its majority of small pore spaces.
- A.** Sandy, clay
  - B.** Sandy, loam
  - C.** Loam, clay
  - D.** Silt, humus
- 20.** Retaining more water, reduced pore spaces, reduced oxygen flow, and restricted root growth are the effects of
- A.** Fertilization
  - B.** Drainage
  - C.** Soil compaction
  - D.** Drought
- 21.** Use the words in the table below to fill in the blank spaces. A word can be used twice.

Macronutrients, hydrogen, micronutrients, oxygen, ammonium nitrate, soluble, phosphorous
--

Several inorganic minerals are essential for plant growth and these are usually obtained by roots from the soil. Plant nutrients are composed of single elements for example, \_\_\_\_\_ or compounds of elements for example, \_\_\_\_\_. In either case, the nutrients are all composed of atoms. Plants need 18 elements for normal growth. Carbon, \_\_\_\_\_, and \_\_\_\_\_ are found in air and water. Nitrogen, phosphorus, potassium, magnesium, calcium, and sulfur are found in the soil. The latter six elements are used in relatively large amounts by the plant and are called \_\_\_\_\_. There are nine other elements that are used in much smaller amounts; these are called \_\_\_\_\_. The micronutrients, which are found in the soil are iron, zinc, molybdenum, nickel, manganese, boron, copper, cobalt, and chlorine. All 18 elements, both \_\_\_\_\_ and micronutrients are essential for plant growth. Most of the soil nutrients that a plant takes up must be in a \_\_\_\_\_ form.



## UNIT

## 15

# Environmental phenomena and related physical concept

## Key Unit Competence

By the end of this unit the learner should be able to relate physics concepts with environmental phenomena.

## Learning objectives

### Knowledge and understanding

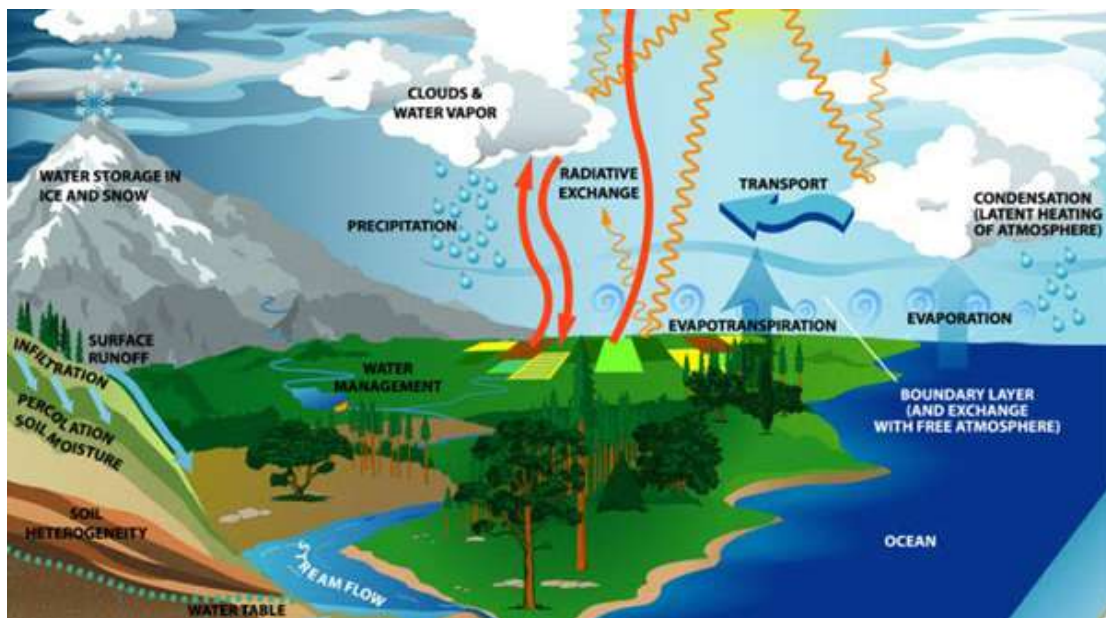
- Recall modes of heat transfer.
- Describe the basic thermodynamics and relate to the environment.
- Describe the basic composition, structure and dynamics of the atmosphere.
- Explain principle of hydrologic cycle and the mechanisms of water transport in the atmosphere and the ground.
- Outline environmental problems such as noise pollution, ozone depletion and global warming.

### Skills

- Apply the basic thermodynamics to environment.
- Explain basic composition, structure and dynamics of the atmosphere.
- Evaluate the principle of hydrologic cycle as mechanisms for water transport in the atmosphere and the ground.
- Carryout investigation on environmental problems such as noise pollution, ozone depletion and global warming in the context of a dynamics atmosphere.

### Attitude and value

- Appreciate that all environmental processes are interdependent.
- Appreciate applications of principles and laws of physics environments issues.
- Appreciate the need to think scientifically about the environment.
- Recognize the value of adapting scientific method in analyzing the environment.
- Appreciate applications of Physics principles and laws in environmental laws.
- Be aware of human activities that affect environment.



## Introduction

### Unit Focus Activity

In recent years, there has been an outcry in the world on climate change and pollution.

1. In what ways has the global climate changed, and the causes and impact of climate change in the world, and ways in which we can control climate change
2. Causes and impact of noise and air pollution and how the pollution can be minimised.
3. How laws in physics, mainly laws of thermodynamics and modes of heat transfer govern processes in our environment
4. Let one of your groups representatives present your findings to the whole class during the class discussion.

Environmental processes influence our lives on a daily basis. For example, climate change is the main cause of prolonged drought and flooding in parts of the world. It is therefore important for everyone in the world to learn how environmental processes take place and the physics behind them, in order to understand and be involved in conserving our environment for our sake. This is what you will gain as we discuss various environmental phenomena and the physics laws governing them in this unit.

## 15.1 Environment and energy transfer

### Activity 15.1

#### To explain the laws that govern heat transfer in the environment

1. Use your knowledge of physics to explain the following environmental phenomena:
  - (a) How heat energy flows from hot to a cold region and not the reverse.
  - (b) How heat travels from the sun through a vacuum in outer space to reach the earth.
  - (c) How sea and land breezes occur.
2. Present your findings to the whole class during the class discussion.

#### Think!

How can you make good use of incident solar radiation to improve the lives of people in your community?

The natural environment consist of all living and non-living things occurring naturally on earth. These things interact with each other in the environment

All living organisms require a regular supply of energy for survival. The main source of earth's energy is the Sun. However, the amount of energy available from sunlight varies widely over the earth's surface due to variation in the number of sunlight hours experienced at different places.

Out of the total energy supplied by the sun, only about 1% is absorbed and used by plants in photosynthesis and then stored as chemical energy. The remaining 99% percent of the energy is lost as heat energy.

The flow and exchange of heat energy between objects in the environment is governed by the laws of thermodynamics and the modes of heat transfer. Let us briefly look of how this happens

## 15.2 Application of laws of thermodynamics in energy transfer in the environment

As we learnt in Unit 6, the first law of thermodynamics relates to conservation of energy. It states that energy cannot be created or destroyed but can be transformed from one form into another.

As such all the energy transformation in the environment are governed by this law. Some example of energy transformation processes in the environment include:

- Conversion of light energy into chemical energy in plants during photosynthesis.
- Conversion of kinetic energy into sound, light and electrical energy during thunderstorms.
- Conversion of heat energy into kinetic energy during heating of liquids and gases in the environment.
- Conversion of chemical energy to heat energy during burning of objects in the environment.

The second law of thermodynamics states that energy in all forms tends to transform itself spontaneously into a more dispersed, random, or less organised form. This law is sometimes stated as "entropy increases" -- entropy being the random, unavailable energy. Whenever energy is converted from one form into another, some of it is given off as heat, which is the most random form of energy.

The following example illustrates how the second law of thermodynamics governs heat transfer in the environment. When a hot frying pan is removed from the stove, at first, the heat energy is concentrated near the pan, which is, relative to the rest of the room in a non-random state. However with time, the pan cools to room temperature with the heat radiated throughout the room. In this state, heat energy is now dispersed and unavailable for cooking; the heat energy flow between the pan and the room has gone towards equilibrium, become more random, and entropy has increased. This is what happens during many heat exchange processes in the environment

### 15.3 Modes of heat transfer in the environment

#### Activity 15.2

To explain the laws that govern heat transfer in the environment

#### Materials

- |                |                  |                     |
|----------------|------------------|---------------------|
| • Metallic rod | • Heating source | • Water in a beaker |
| • Ink          | • Candle wax     | • Small nails       |
| • Retort stand | • Tripod stand   | • Steel wire        |

#### Steps

1. Stick the candle wax at different points towards one end of the metallic rod. Fix the nails on each candle wax as shown in Fig. 15.1.
2. Now hold the rod from the other end and start heating it as shown in Fig 15.1.

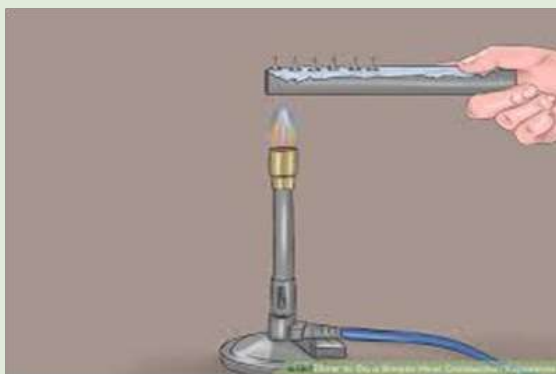


Fig. 15.1: Heating a metal rod with nails attached to it using candle wax

3. Heat the metallic rod for some time. What will happen to the nails on the candle wax? Explain.
4. Remove the rod from the Bunsen burner and move your hands near but beside the burning flame. What do you feel? Explain.
5. Now place the tripod stand over the flame and then the steel wire on the tripod stand. What is the importance of the steel wire?
6. Put one drop of ink at one side of the water in the beaker. Place the beaker on the tripod stand and start heating. What do you observe after 10 minutes of heating? Explain.
7. While heating, move your hands near the Bunsen burner. What do you feel? Explain.
8. When heat flows between two objects, does the temperature increase in one object always equals to the temperature decrease of the other object? Discuss.
9. Describe how the thermal energy of an object changes when the temperature of an object changes.
10. Explain the three modes of heat transferring the environment.
11. Note down your findings in your notebooks.
12. Share your findings with your friend and then to the whole class
13. Discuss your findings as the whole class with the help of the teacher and note them down in your notebooks.

**Conduction** is the transfer of heat energy or movement of heat through a substance without the movement of the particles of the substance. Conduction also takes place between two bodies that are in contact with each other. Materials, which conduct heat well, are called conductors of heat. Electrical conductors (such as metals) are also good conductors of heat.

Materials, which do not conduct heat well, are called insulators. Electrical insulators (for example, wood or glass) are usually good insulators of heat. Most insulators are materials of low density like air or foamed plastic. Insulators are used to prevent heat from moving from one object to another.

Examples of heat transfer in the environment include heat flow through solid metallic ores and rocks.

**Convection** is the transfer of heat energy in a fluid by the movement of warmer and cooler fluid particles from place to place. The hot fluid particles reduce in density and move up while the cold particles being denser drop down to occupy the space left by the rising hot particles (Fig. 15.2). This movement sets up convective currents in the fluid and results in the heat energy being transferred to all the fluid particles.



Fig. 15.2: convectional currents in water

In the environment, convection causes sea and land breezes (Fig 15.3) that affect the weather around large water bodies e.g. causing convectional rainfall near oceans.

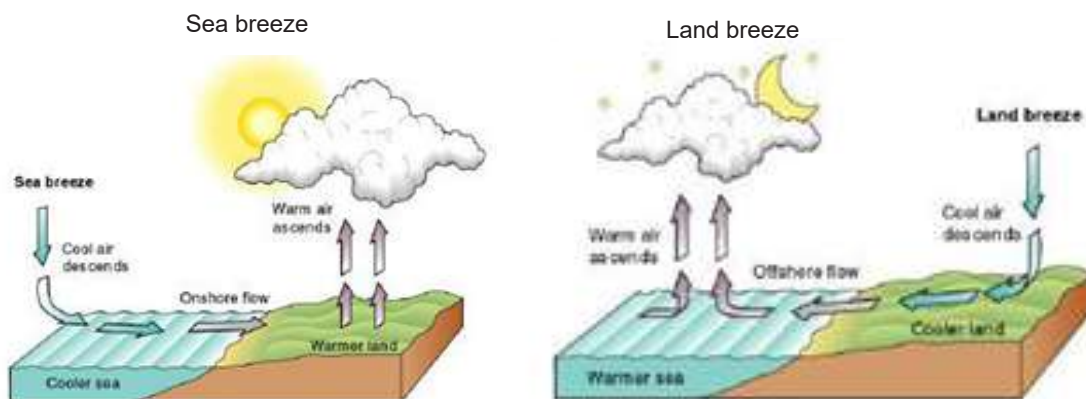


Fig. 15.3: Sea breeze and land breeze

Convection of molten rock inside the earth crust is in some cases responsible for some volcanic eruptions and movement of some plate tectonics. Through convection, warm water around the equator moves towards the poles while the cooler water at the poles moves towards the equator. This facilitates the circulation of ocean water. Convectional currents of the air inside a rain cloud cause thunderstorms. In our houses, convection through which hot air rises and escapes through the chimney while cold air is drawn into house through doors and windows provides air circulation in the house.

**Radiation** is the transfer of energy by electromagnetic waves. Radiation does not necessarily require a material medium for the heat energy to flow through, as is the case with convection and conduction. The heat energy in hot objects like the sun and fires is emitted and propagated in the form of electromagnetic radiations like infrared and gamma rays. It is by radiation that heat energy moves through vacuum.



Heat energy moves through radiation from the sun to reaches the environment. Once in the environment, the radiations can be both useful and harmful. For example, the warm it produces facilitates quick growth of plants. However, some radiations like gamma rays are known to cause problems like cancer of the skin.

### Exercise 15.1

**For questions 1 - 2, select the most appropriate answer.**

1. The second law of thermodynamics states that heat cannot flow from a colder to a hotter temperature unless work is done, and it cannot be converted completely into work.
  - A. True
  - B. False
2. According to the first law of thermodynamics, the increase in the thermal energy of a system is equals to the work done on the system and the amount of heat added to the system.
  - A. True
  - B. False
3. (a) Explain how the thermal energy of a closed system changes with time.  
(b) What law of nature prevents heat from spontaneously flowing from a lower temperature to a higher temperature?  
(c) How does heat flow from the ground to the atmosphere to satisfy the first law of thermodynamics?
4. Explain which has the greater amount of thermal energy, one litre of water at 50°C or two litres of water at 50°C.
5. Suppose a beaker of water is heated from the top, predict what is more likely to occur in the water-heat transfer.
6. Explain whether or not the following statement is true: if the thermal energy of an object increases, the temperature of the object must also increase.
7. Explain the three different ways heat is transferred from one point to another in the different states of matter.
8. Explain why the air temperature near the ceiling of a room tends to be warmer than one near the floor.
9. Explain why materials that are good conductors of heat are poor insulators.

## 15.4 Noise Pollution

### Activity 15.3

#### To identify causes and effects of noise pollution

#### Materials

- Radio
- Internet enabled computers
- Reference books

#### Steps

1. Switch the radio on and tune it to full volume for 2 minutes. Now, tune it to low volume.
2. Briefly discuss the meaning of noise pollution.
3. Outline the causes of noise pollution in your environment and name some places in Rwanda where noise pollution is highly experienced.
4. Conduct a research from the Internet and reference books about the effects of noise pollution to the general public.
5. Note down your findings in your notebooks.
6. Share your findings with your friend and then with the whole class

Noise pollution is undesired sound that is disruptive or dangerous and can cause harm to life, nature, and property.

The hazardous effects of noise depend on its intensity (loudness in decibels), duration, and frequency (high or low). High and low pitch noise is more damaging than middle frequencies. Noise may be ambient (constantly present in the background) or peak (shorter, louder sounds).

Some of the negatives impacts of noise pollution in the environment are:

1. **Physiological problems** – among other physiological damages and problems, noise causes Noise-Induced Hearing loss (NIHL) in humans, damage to the inner ear (loud, abrupt sounds can damage the eardrum, while sustained lower volume noise can damage the middle ear). Noise also causes headaches and feelings of fatigues.
2. **Emotional problems** – Such problems include irritability and nervousness. It is very uncomfortable and stressing to stay in a noisy place.
3. Noise **disrupts sleep** and **communication**,
4. Noise **disrupts the natural order** of activities in an ecosystem; for example, the feeding and breeding of livestock the wildlife on land and marine ecosystems is disrupted by noise.
5. **Structural damage** to property like buildings and trees due to vibrations induced by sound waves.



Some causes of noise pollution in the environment include industrial and construction activities, moving aircrafts and vehicles, household appliances like radios and machines like lawn mowers and tractors.

In Rwanda, noise pollution is experienced in a few areas including near airports, industries and roads. However, good planning by the government especially in the location of airports and industries has reduced the number of people affected by noise pollution.

**Take care!**

Hey!! It's always better to limit the volume of your electronic devices especially headphones, because hearing loss is a result of cumulative noise over time. It's also a good investment to get your ears cleaned; large amounts of wax can cause an annoying ringing in the ears called tinnitus. Home remedies, such as using Q-tips or ear candles are not recommended by medical professionals. You can visit an audiologist or doctor for the service

**Think!**

Suggest some of the ways through which noise pollution can be minimized in your area.

**Exercise 15.2**

**For questions 1 - 5 select the most appropriate answer from the choices given.**

- Which of the following jobs carries a high risk of exposing a worker to hearing damage?  
**A.** An airport employee                      **B.** Landscaping and lawn care worker  
**C.** Office worker                                      **D.** A and B
- Why should you be concerned with the noise level of the activity you are such as mowing the grass or listening to music, even if you are wearing ear protection?  
**A.** It may prevent you from getting tinnitus  
**B.** Noise can still harm your ears, its depends on the pitch  
**C.** You need to think about how the noise will affect others  
**D.** All the above
- \_\_\_\_\_ is the unit used to measure the loudness of sounds  
**A.** Decibel    **B.** Meter  
**C.** Pitch    **D.** Acoustic frequency

4. Which of the following is a way in which you can avoid noise pollution?
  - A. Wear earplugs when you go to music concerts or other loud sound events.
  - B. Avoid listening to music through headphones or headsets at unsafe levels
  - C. Wear ear plugs when you are using power equipment such as lawn mower and leaf blowers
  - D. All of the above
5. \_\_\_\_\_ is an immediate and permanent loss of hearing caused by a short, intense sound
  - A. Sound frequency
  - B. Amplitude
  - C. Acoustic trauma
  - D. Temporary threshold shift
6. What is noise pollution?
7. What are the most causes of noise pollution in your area?
8. Discuss the negative effects of noise pollution?

## 15.5 Air pollution

### 15.5.1 Definition of air pollution

#### Activity 15.4

#### To define air pollution

##### Materials

- Dry heap of litters in the school compound
- Matchbox

##### Steps

1. Collect the litter in your compound and make a heap in the pit far away from the buildings.
2. Use the matchbox to lit the litter. Observe the smoke coming from of it.
3. Now take a keen look at the picture in fig. 15.4. What do you see?



Fig. 15.4: Air pollution

4. Briefly discuss the meaning of air pollution.
5. Conduct a research from the Internet and reference books about the effects of air pollution to the general public and note down your findings in your notebooks.
6. Discuss your findings with the whole class and with the help of the teacher note them down in your notebooks.

Air pollution is the introduction of gases, dust particles, fumes (or smoke) or odour that are harmful to humans, animals and plants into the atmosphere.

### 15.5.2 Causes of air pollution

#### Activity 15.5

#### Fieldwork: To identify causes of air pollution

Your teacher will organize a trip to one of the industrial sites in Rwanda for you to learn application of concepts and principles in physics.

While in the industrial area, in addition to observing the application of Physics principles, observe and make a report on the ways industries pollute the environment, and measures the industries have taken to minimize pollution.

Pollution can result from both natural occurrences and human activities.

**Natural events** that pollute the air include forest fires, volcanic eruptions, wind erosion, pollen dispersal, evaporation of organic compounds and natural radioactivity. Pollution from natural occurrences though is not very frequent and is relatively hard to control.

**Human activities** that result in air pollution include:

#### 1. Emissions from industries and manufacturing activities

Waste incinerators, manufacturing industries and power plants emit high levels of carbon monoxide, organic compounds, and chemicals into the air.

#### 2. Burning Fossil Fuels

Motor vehicles, trains, shipping vessels and airplanes all burn lots of fossil fuels to get the energy that drives them. The fumes emitted from the combustion contain dangerous gases such as carbon monoxide, oxides of nitrogen, hydrocarbons and dust particulates. Some of these gases further react with gases in the environment to form other toxic gases.

This is a major cause of pollution and one that is very difficult to manage because humans heavily rely on such modes of transports for people, goods and services.

### 3. Agricultural and household chemicals

Agricultural chemicals like fertilizers, insecticides and pesticides, household fuel chemicals like kerosene, fumigators homes, cleaning products and paints emit harmful chemicals into the air that cause pollution.

#### Health matters!

When using household chemicals inside the house or offices, ensure the room is well ventilated to avoid inhaling too much of the dangerous chemicals.

Use incinerators when burning waste that release dangerous gases and chemicals to avoid them spreading all over the environment where people are living

### 15.5.3 Effects of air pollution

#### Activity 15.6

#### To identify the effects of air pollution

##### Steps

1. Outline the problems that result from air pollution.
2. Discuss the methods that can be used to curb the problem.
3. Note down your findings in your notebooks.
4. Share your findings with your friend and then with the whole class

The following are some major effects of air pollution:

1. **Acidification:** This is a chemical reaction involving air pollutants creating acidic compounds in the atmosphere. When these compounds dissolve in rain drops, they form in acidic rain. When acid rain falls over in an area, it can corrode iron sheets; kill trees and harm livestock, wildlife and aquatic animals like fish. In the soil, the acid changes the chemistry of the soil making it unfit for microorganisms.
2. **Eutrophication:** This occurs when rain water dissolve chemicals like nitrogenous compounds in the atmosphere then drains into water bodies and soils. The compounds, being nutrients, result in excessive algae growth that may cause death of living organisms due to lack of oxygen
3. **Particulate matter:** Air pollutants can be in the form of particulate matter, which can be very harmful to our health. The effect usually depends on the length of exposure time as well as the kind and concentration of chemicals and particles one is exposed to.

Short-term effects include eye irritation, nose, throat and upper respiratory infections like bronchitis and pneumonia, headaches, nausea, and allergic reactions. Long-term health effects include chronic respiratory disease, lung cancer, heart disease, and even damage to the brain, nerves, liver, or kidneys and lung damage.

### 15.5.4 Prevention, monitoring and control of air pollution

Measures to prevent and control air pollution should be a collaborative effort between governments (laws) and individual actions. In many big cities, monitoring equipment has been installed at many points in the city.

The Government of Rwanda has over time put in place laws and polices to prevent air pollution in the country. An example of this is the adoption of the ministerial order N0003/16.01 of 15/07/2010 that prohibit activities that pollute the atmosphere.

#### Exercise 15.3

#### Multiple choice questions 1 - 5 select the most appropriate answer

- Which gas makes up the largest part of air?  
**A.** Carbon dioxide                      **B.** Oxygen  
**C.** Nitrogen                                **D.** Sulfur dioxide
- Which of the following substances is not an atmospheric pollutant?  
**A.** Carbon dioxide                      **B.** Helium  
**C.** Oxides of nitrogen                **D.** Sulfur dioxide
- Why is carbon dioxide a deadly air pollutant?  
**A.** Colourless, highly toxic with a pungent odour  
**B.** Greenish in colour, highly toxic and odourless  
**C.** Colourless, odourless and highly toxic  
**D.** Ozone, is abundant in this layer.
- A safe level of noise depends on?  
**A.** level of noise and exposure to noise      **B.** area  
**C.** pitch                                      **D.** frequency
- Main sources of noise pollution are  
**A.** Transportation equipment      **B.** Musical instruments  
**C.** Heavy machinery                **D.** A and C both
- Name some health effects of carbon dioxide as a pollutant
- State two effects of noise pollution

## 15.6 Structure and composition of the atmosphere

### Activity 15.7

#### To describe the structure of the atmosphere

#### Materials

- Plain paper
- Reference materials and internet

#### Steps

1. With the help of research from reference books or internet, name the components that make up the atmosphere. Note them down on the plain paper provided to you.
2. On the plain paper, draw the structure of the atmosphere.
3. Compare your findings with those of your classmates.
4. In which part do you think ozone gas would be found?

The atmosphere of Earth is the layer of gases, commonly known as air that surrounds the planet Earth and is held in place by Earth's gravity. The air consists of a mixture of nitrogen (78%), oxygen (21%), and other gases (1%) that surrounds Earth. High above the planet, the atmosphere becomes thinner until it gradually fades out in space (See Fig. 15.5)

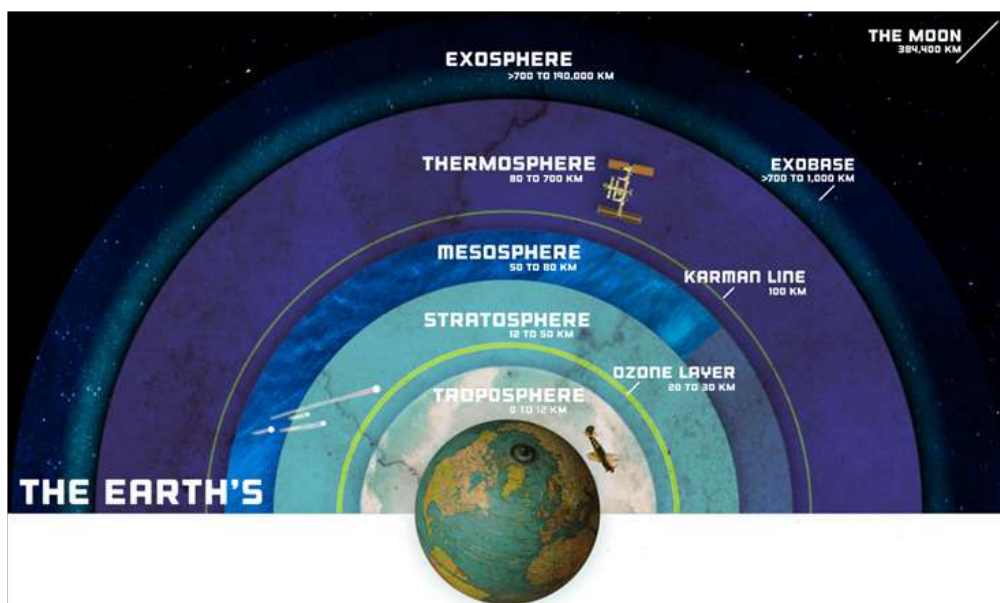


Fig. 15.5: The structure of the atmosphere

The **atmosphere** is structured into 5 layers. It is thickest near the surface and thins out with height until it eventually merges with space.

- **Troposphere** - is the layer just above the Earth's surface and contains about 75% of the atmospheric mass. Weather processes occurs in this layer. Temperature and pressure decrease as you go higher up the troposphere.
- **Stratosphere** is the layer immediately above the troposphere. It is warmer at the top than the bottom, the direct opposite to the situation in the troposphere. The stratosphere contains the Ozone Layer, which is a thin layer of ozone molecules with three oxygen atoms. This layer forms a protective layer that shields life on Earth from the harmful ultraviolet radiation from the sun.  
Many aircrafts fly through the stratosphere to avoid turbulence that is high in the troposphere.
- **Mesosphere** is the layer immediately above the stratosphere. It s a cold layer in which temperature generally decrease with increase in altitude. The layer is highly rarefied (with very low oxygen) but is thick enough to slow down meteors that move at very high speeds in the atmosphere where they burn up, leaving fiery trails in the sky at night.
- **Thermosphere** is the layer immediately above the mesosphere. The density of air in this layer is very low. In this layer, the temperature is very high in that the few molecules present in it receive very high amounts of energy from the Sun.  
The gases in the thermosphere are not uniformly distributed but are stratified (exist in layers) according to their molecular masses.
- **Exosphere** is the uppermost region of Earth's atmosphere. It gradually fades into the space. Air in this layer is extremely thin, almost the same as the airless vacuum of space.  
Most satellites orbit the earth in the thermosphere and the exosphere.

### **Importance of atmosphere**

- The atmosphere through the ozone layer shields life on Earth from the harmful ultraviolet radiation from the sun. It traps heat giving the earth a comfortable temperature.
- The gases in the atmosphere are necessary for life on earth. For example, animals breathe in oxygen from the atmosphere for their respiration, plants absorb carbon dioxide from the atmosphere and use it in photosynthesis. Nitrogen is fixed in the soil by bacteria and is used in protein manufacture.



## 15.7 Climate change science

### 15.7.1 Introduction to climate change

#### Activity 15.8

#### To differentiate between climate and weather

##### Steps

1. Look outside your classroom. Is there sunshine, rain, cloud or what do you see in the atmosphere?
2. Briefly discuss the difference between weather and climate and note it down your notebooks.
3. Discuss your facts with your friend and then with the whole class

**Weather** is the short-term state of the atmosphere, which may be hot or cold, wet (rainy) or dry, calm or stormy, clear or cloudy. These weather conditions occur in the troposphere, and may change one hour to the next or from one day to the other. For example it may be sunny in one day and rainy the following day

**Climate** is the average of the prevailing weather conditions in a region over a long period of time, usually a year. It is determined by averaging measurements of temperature, air pressure, humidity, precipitation, sunshine, cloudiness, and winds throughout the year and averaged over a series of years

#### Activity 15.9

#### To define climate change

1. Discuss in your group the meaning of climate change
2. Identify eight causes of climate change.
3. Discuss the effects of climate change and the measures that can be taken to reverse and minimise climate change
4. Present your findings to the whole class in a class discussion.

Climate change refers to the large-scale changes in the long-term averages of weather patterns.

The following are some **natural causes of climate change**

**Continental drift:** The continents as established today were formed millions of years ago when the earth's landmass began gradually segmenting and drifting apart. The drifting of the continents continues even today, and continues to impact on the flow of ocean currents and winds and position of water bodies which affect the climate.

**Volcanoes:** A volcanic erupts and throws large volumes of sulphur dioxide ( $\text{SO}_2$ ), water vapour, dust, and ash into the atmosphere. The gases and dust particles



partially block the incoming rays of the sun, leading to cooling. Sulphur dioxide combines with water to form tiny droplets of sulphuric acid that may stay in the atmosphere for a long period reflecting back the rays of sunlight blocking them from reaching the earth leading to cooling.

**The earth's tilt:** The earth's axis is tilted at an angle of  $23.5^\circ$  to the plane of the orbit along which it revolves round the sun. In one half of the year, the northern hemisphere tilts towards the sun hence it is summer in that region. The reverse happens in the other half year causing winter. This is how the earth's tilt causes seasons. Changes in the tilt of the earth can affect the severity of the seasons - more tilt means warmer summers and colder winters and vice versa

The earth's axis is actually not fixed, but moves, at a rate of about half a degree each century. This gradual change in the direction of the earth's axis, called precession is partially responsible for climate change.

**Ocean currents:** Winds push horizontally against the sea surface and drive ocean currents. The currents move vast amounts of heat across the planet. Much of the heat that escapes from the oceans is in the form of water vapour, which is the most abundant greenhouse gas on Earth. The water vapour leads to the formation of clouds that have a net cooling effect. However, ocean currents have been known to change direction or slow down in speed, which in one way or another affects climate.

## 15.7.2 Human causes of climate change

Human causes of climate change involves engaging in activities that lead to

- Ozone layer depletion
- Green house effect

Let us discuss each of these two causes of climate change in details'

### 15.7.2.1 The ozone layer depletion

#### (a) Description of ozone layer

#### Activity 15.10

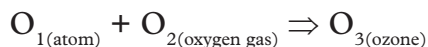
#### To describe ozone layer

#### Materials

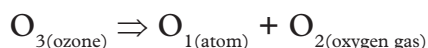
- Science encyclopedia
  - Internet articles on ozone layer
1. Using the Internet and reference books, briefly describe the ozone layer.
  2. Where is ozone found in the atmosphere?
  3. What role does the ozone layer play in the atmosphere?

4. What human activities can cause the depletion of the ozone layer?
5. What should the government of Rwanda do about the protection of the ozone layer?
6. Share your findings with the whole class

Ozone is a molecule made up of three oxygen atoms. It is formed when high-energy ultraviolet (UV) light collides with the oxygen gas molecule ( $O_2$ ) causing it to split into two oxygen atoms ( $O_1$ ). These atoms are unstable on their own and bind themselves with the unsplit oxygen molecules forming ozone.



This process is reversed when ozone absorbs the UV rays emitted by the sun. The energy of the UV rays splits ozone molecules ( $O_3$ ) into one free oxygen atom ( $O_1$ ) and one molecule of oxygen gas ( $O_2$ ).



This is the process through which ozone protects the earth from the harmful effects of UV radiations from the sun by absorbing them, allowing only a small amount to reach the Earth's surface. This accounts for the increase in temperature with altitude in the stratosphere where the Ozone layer is located (upper region of stratosphere).

### (b) Causes of ozone layer depletion

Ozone layer is being destroyed by a group of manufactured chemicals, containing chlorine and/or bromine. The chemicals are called "ozone-depleting substances" (ODS).

ODS are very stable, nontoxic and environmentally safe in the lower atmosphere. However, their stability allows them to float up, intact, to the stratosphere where they are split apart by the ultraviolet light, releasing chlorine and bromine. Chlorine and bromine vigorously bombard ozone, by plucking off one atom from the ozone molecule. A single molecule of chlorine split thousands of molecules of ozone.

The main Ozone-Depleting Substances (ODS) are:

**Chlorofluorocarbons (CFCs):** Are the most widely used ODS and account for over 80% of ozone depletion. They are used as coolants in refrigerators, freezers and air conditioners. They are found in industrial solvents, dry-cleaning agents and hospital sterilants and in foam products such as soft-foam padding

**Halons:** Are used in some fire extinguishers

**Methyl Chloroform:** Is used mainly in industries for vapour degreasing, in aerosols and adhesives.

**Carbon Tetrachloride:** Is used in solvents and some fire extinguishers.

**Hydrofluorocarbons (HCFCs):** They have become suitable substitutes for CFCs. They cause less stratospheric ozone depletion than CFCs.

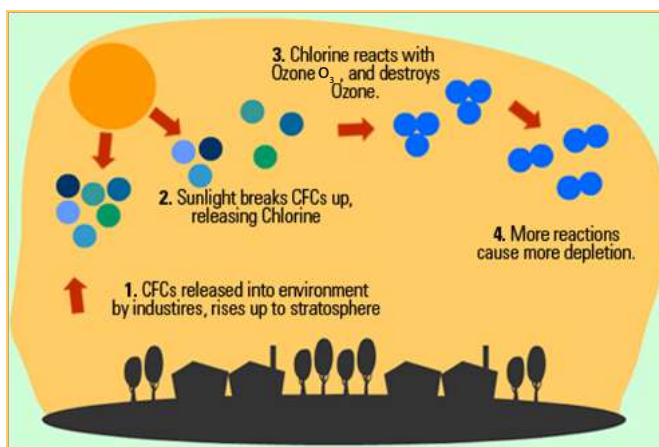


Fig. 15.6: Destruction of ozone layer by CFC's

### (c) Impact of ozone depletion

Continued Ozone layer depletion allows more UV rays to reach the earth where they will cause serious impacts on humans, animals and plants including:

- Harm to human and animal health: - more skin cancers, sunburns and premature aging of the skin, cataracts, blindness and other eye diseases and weakening of the human immune system.
- Adverse impacts on agriculture, forestry and natural ecosystems: reduced growth, photosynthesis and flowering of plants
- Damage to marine life:
- Materials: degrading of materials like wood, plastic, rubber, fabrics and many construction materials.

### (d) Measures taken globally and by Rwanda to protect the ozone layer

Many nations of the world including Rwanda have so far signed an international agreement known as the Montreal Protocol on Substances that Deplete the Ozone Layer. This nations have committed to discontinue production of CFCs, halons, carbon tetrachloride, and methyl chloroform (except for a few special uses), and develop more "ozone-friendly" substitutes.

Rwanda also adopted the ministerial order 0006/2008 of 15/08/2008 regulating the importation and exportation of ozone layer depleting substances, products and equipment containing such substances ozone depleting substances (ODS).

Key institutions like Rwanda environment management authority (REMA) and Rwanda standard board (RSB) serve as watchdogs to ensure effective implementation of the foregoing order and general national environmental policy.

Commendation: Rwanda's enormous contribution to the preservation of the ozone layer earned it a 2012 Ozone Protection Award by the United Nations environment program (UNEP).

**Exercise 15.4**

**For questions 1 - 8, select the most appropriate answer.**

1. Ozone in the troposphere is a harmful pollutant. True or false?
  - A. True
  - B. False
2. Much of the X-ray and UV radiation from the sun is absorbed in the \_\_\_\_\_
  - A. Stratosphere
  - B. Thermosphere
  - C. Troposphere
  - D. Mesosphere
3. Where in the atmosphere is ozone found?
  - A. Close to the earth
  - B. High up in the atmosphere
  - C. There is no place
4. Which of the following represents the ozone gas molecule?
  - A.  $O_4$
  - B.  $O_3$
  - C.  $O_9$
  - D.  $O_6$
5. The ozone layer is mainly found at \_\_\_\_\_ above the surface of the earth
  - A. 20 to 30 km
  - B. 30 to 40 km
  - C. 10 to 20 km
  - D. 40 to 60 km
6. Ozone layer absorbs the sun's rays. Which of the following radiation does it prevents from falling on the earth's surface;
  - A. Gamma radiation
  - B. X-rays radiation
  - C. Infrared radiation
  - D. UV radiation
7. What is the number of atoms in the ozone molecule?
  - A. 2
  - B. 3
  - C. 4
  - D. 1
8. Which of the following is true?
  - A. Cars are solely responsible for ozone pollution
  - B. Only chemical industries are responsible for smoke
  - C. Emissions from cars and industries contribute to ozone pollution
9. Which one of the following is the largest ozone depletion substation that is emitted through human activities?
  - A. Nitrous oxide
  - B. Carbon monoxide
  - C. Atomic bromine
  - D. Atomic chlorine
10. (a) Discuss how the ozone layer is formed in the atmosphere?  
 (b) Why do we care about atmospheric ozone?

- (c) Is total ozone uniform over the globe? Discuss.
11. Write a brief report on ozone: how it is formed, its importance and effects to animals and plants.
  12. What are the principal steps in stratospheric ozone depletion caused by human activities?
  13. What emissions from human activities lead to ozone depletion?
  14. What are the reactive halogen gases that destroy stratospheric ozone?
  15. Does depletion of the ozone layer increase ground level ultraviolet radiation?
  16. Is depletion of the ozone layer the principal cause of climate change? Explain.

### 15.7.2.2 Greenhouse effect and global warming

#### (a) Introduction to the greenhouse effect

#### Activity 15.11

#### To explain the greenhouse effect

#### Materials

- A greenhouse structure
- Reference books
- Internet

#### Steps

1. Your teacher will organize a trip to a greenhouse structure where horticultural plants are grown
2. While there, ask the greenhouse attendant how the green house accelerates the growth of plants. Note your findings in a note book
3. With the help of the Internet and reference books, describe greenhouse effect.
4. Explain the causes of the green house effect.
5. Share your findings with your class mates

When sunlight reaches the Earth's surface, it is absorbed by the Earth or is reflected back into the atmosphere. Once absorbed, the earth releases some of the energy back into the atmosphere as heat in form infrared radiation. Greenhouse gases like water vapor ( $\text{H}_2\text{O}$ ), carbon dioxide ( $\text{CO}_2$ ), and methane ( $\text{CH}_4$ ) and Nitrous oxide ( $\text{N}_2\text{O}$ ) in the atmosphere absorb the heat energy from the earth and radiate it back to the earth (Fig. 15.5). This slows or prevents the loss of heat to space and makes the earth warmer than it would otherwise be. This process is commonly known as the "greenhouse effect."

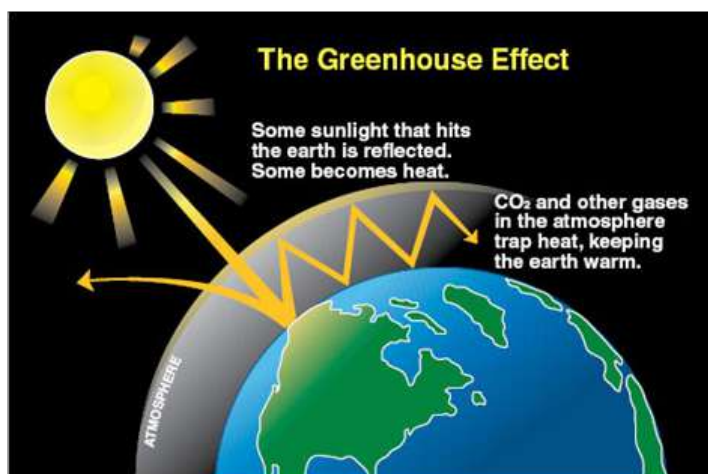


Fig. 15.7: Greenhouse effect

### (b) Causes of greenhouse effect

Some human activities greatly increase the release of greenhouse gases to the atmosphere, increasing the green house effect.

Some of these human activities include:

- **Burning coal, oil and gas** – this produces carbon dioxide and nitrous oxide.
- **Cutting down forests (deforestation)**. Trees help to regulate the climate by absorbing CO<sub>2</sub> from the atmosphere. So when they are cut down, that beneficial effect is lost and the carbon stored in the trees is released into the atmosphere, adding to the greenhouse effect.
- **Increasing livestock farming**. Cows and sheep produce large amounts of methane when they digest their food.
- **Use of fertilisers containing nitrogen** produce nitrous oxide emissions.
- **Production of fluorinated gases** - these gases produce a very strong warming effect, many times greater than that by CO<sub>2</sub>.

### (c) Impacts of the greenhouse effect

The greenhouse effect is the main cause of global warming which is the rise in the average global temperatures. This is gradually affecting life on earth.

Some of the effects of global warming in the world today include:

- **Changes in rainfall averages and patterns**: Some areas especially in the northern hemisphere are now experiencing excessive rainfall leading to flooding while others experiencing low rainfall through out the year leading to drought. Shifts in seasons have been observe in many parts of the world.

- **Melting of glaciers, sea ice and ice sheets:** Glaciers in the high altitude regions in the world including the Alps, Atlas and Himalayas, are melting and shrinking at alarming rates. Sea ice in the Arctic regions has been melting and decreasing at an increasing rate. The Greenland and Antarctic ice sheets that store the most of the world's fresh water, are both shrinking at an alarming rate.
- **Raising sea levels:** Due to the melting of ice sea levels are rising globally. The rate of rising has increased in recent decades.

#### **(d) Measures that reduce the greenhouse effect and global warming**

The following measures can help bring down the emissions of greenhouse gases in the atmosphere hence minimize the greenhouse effect and global warming.

1. **Reducing the use of fossil fuels:** Burning of fossil fuels like wood or coal produces more carbon emissions than other sources of energy. Reducing the use of fossil fuels directly reduce the release of greenhouse gases to the atmosphere.
2. **Use of Green energy.** This is energy that comes from renewable sources such as sunlight, wind, rain, tides, plants, algae and geothermal heat. These energy resources are renewable, meaning they're naturally replenished. These sources do not release greenhouse gases to the environment
3. **Afforestation:** Trees absorb carbon dioxide gas from the atmosphere and release oxygen. Absorbing carbon dioxide gas reducing the quantity of greenhouse gases in the atmosphere.
4. **Using carbon efficient technologies:** For example developing vehicles that emit negligible amounts of carbon dioxide into the atmosphere.

#### **(e) Useful application of the greenhouse effect**

The greenhouse effect is applied in structures such as greenhouses, which are house-like structures that are fully covered with light trapping polythene paper. Horticultural plants are then planted inside the structure. The structures trap the sun's energy and keep the plants warm, even in cold times. The warmth makes the plants grow much more faster.

### **Exercise 15.5**

**For questions 1 - 5, select the most appropriate answer.**

1. Greenhouse effect means-
  - A. Release of heat from the plants during daytime
  - B. Slowing down the release of heat into space at night
  - C. Quickening the release of heat into space



2. The extent to which greenhouse gas warms the earth depends on the length of time it remains in the atmosphere and its ability to absorb energy.
  - A. True
  - B. False
3. Which greenhouse gas has the highest global warming potential?
  - A. Carbon dioxide
  - B. Methane
  - C. Nitrous oxide
  - D. Sulfur hexafluoride
4. What is the largest source of greenhouse gas emissions in Rwanda?
  - A. Agriculture
  - B. Transportation
  - C. Electricity production
  - D. Home heating
5. Which of the following gases are greenhouse gases?
  - A. Carbon dioxide and methane
  - B. Oxygen and nitrogen
  - C. Carbon dioxide and oxygen
  - D. Methane and oxygen

## 15.8 The hydrosphere and hydrologic Cycle

### 15.8.1 Description of the hydrosphere

#### Activity 15.12

#### To describe the hydrosphere

##### Materials

- Reference books

##### Steps

1. With the help of reference books, describe the hydrosphere.
2. Present your findings to the rest of the class in a class discussion.

The hydrosphere is the combined mass of water found on, under, and over the surface of a planet or is the liquid water component of the Earth. It includes the oceans, seas, lakes, ponds, rivers and streams water vapour in the atmosphere, groundwater held in soil and rocks and ice on lakes and higher on the mountains. The hydrosphere covers about 70% of the surface of the Earth and is the home for many plants and animals. The study of water is known as hydrology, and the scientists who study water are called hydrologists. The chemical formula for water is  $H_2O$



## 15.8.2 The hydrologic cycle

### Activity 15.13

To describe the hydrological cycle

#### Materials

- Manila paper
- Internet
- Reference books

#### Steps

1. Using Internet and reference books, identify the elements in the hydrological cycle.
2. On the manila paper illustrate the hydrological cycle with a diagram.
3. Describe fifteen uses of water
4. Present your findings to the whole class in a class discussion.

The water cycle, also known as hydrological cycle, is the natural sequence through which water passes into the atmosphere as water vapour, precipitates to earth in liquid or solid form, and ultimately returns to the atmosphere through evaporation.

Fig. 15. 8 shows an illustration of the water cycle.

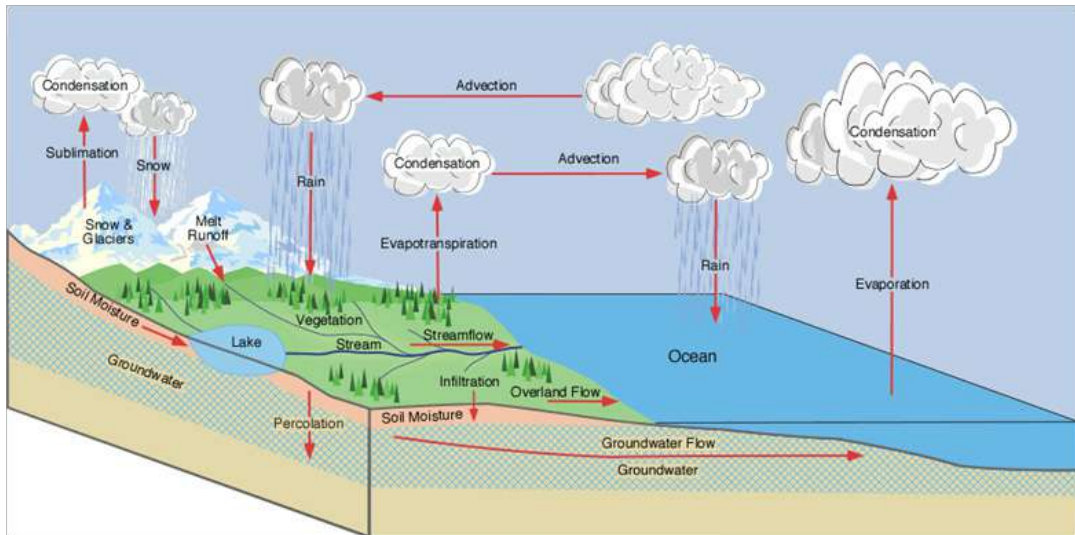


Figure 15.8: The hydrological cycle

The hydrologic cycle does not have a particular starting point. But let us begin at the surface water bodies. Heat from the sun heats the water at the surfaces of water bodies like oceans, lakes, dams and rivers and make it to **evaporate** into the atmosphere. Some little amount of water vapour is added into the atmosphere

through transpiration by plants and evaporating directly from the soil in the processes collectively referred to as **evapotranspiration**. A relatively small amount of moisture sublimates from snow and ice into vapour that rises into the atmosphere. As the water vapour rises, it cools and eventually condenses to form clouds. Air currents move the clouds around the globe. The clouds continue growing in size and colliding as they move and eventually fall down from the sky as precipitation. Some precipitation falls in the form of ice and snow and accumulates as glaciers on mountains and ice sheets, Most precipitation falls as rain into the oceans or onto land, where much of it flows by gravity to the ocean and surface runoff through streams and rivers. A portion of the runoff groundwater seeps (percolates) into the ground and is either stored as ground water in aquifers (saturated rock), absorbed by plants or later emerges onto the surface as fresh water springs and streams. From the oceans, glaciers, ground and inside the plants, the cycle begins once again and continues for ever.

### **15.8.3 The importance of water**

Certainly you must have heard the saying “water is life”. This saying is so true because water is so important that without it humans, plants and animals cannot survive on earth. The following are just a few uses of water; the list is endless.

- 1.** Water in our bodies – Over 60% of our body is water. It is a key component of all body fluids, and regulates body temperature.
- 2.** Water in plants – it is a key component in all plant tissues and is a requirement in photosynthesis and a medium for transport in plants.
- 3.** Water for domestic use – In our homes, we use water for drinking cooking and washing.
- 4.** Water for industrial use: - In industries, water is used for cleaning, cooling and as ingredient in many industrial products
- 5.** Water for power generation – Water is used to generate hydroelectric power.
- 6.** Water for transport – Water is used in transport of people and goods using canoes, boats and ships.
- 7.** Water as an habitat for marine animals- Water is the home to all marine animal including fish, amphibians and hippos.
- 8.** Water for recreation – Water supports many recreational activities like swimming, diving, skating etc.

### Exercise 15.6

For questions 1- 6, select the most appropriate response from the options given

- What is the other name for water cycle?
  - Hydrologic cycle
  - Happy fun time cycle
  - Tectonic cycle
  - Hydraulic cycle
- What is the most important step in the hydrologic cycle
  - Evaporation
  - Condensation
  - Precipitation
  - All of them
- The water cycle starts at
  - Condensation
  - Evaporation
  - It has no beginning or end
  - Trees
- Clouds form through this process
  - Transpiration
  - Condensation
  - Infiltration
  - Evaporation
- Which of the following is a process that occurs in the water cycle?
  - Precipitation
  - Condensation
  - Evaporation
  - All the above
- \_\_\_\_\_ is the only substance on earth that commonly exists in all of the three states of matter(solid, liquid, gas)
  - milk
  - oil
  - water
  - paraffin
- Fill in the gaps**  
As water vapor cools below 100 degrees Celsius, it condenses to \_\_\_\_\_
- Define the term hydrosphere.
- State five uses of water.
- Briefly describe the water cycle
- Discuss four ways in which we can conserve water.

## 15.9 Clouds

### Activity 15.14

To explain formation of clouds and identify types of clouds

#### Materials



- Open ground
- Reference books
- Manila paper
- Internet

### Steps

1. On a cloudy day or session, move out of the classroom in groups into an open ground.
2. Look high up into the sky and observe the clouds. Identify different types of clouds based on their colours and heights above the ground. Record your observations in a note book,
3. Move to the classroom. Use the Internet and reference books to identify the names of the different types of clouds you observed based on their characteristics. Prepare a table on your manila paper and fill this information.
4. Discuss in your group how clouds form and record your findings.
5. Share your findings with your friends and then with the whole class
6. Present your findings and the clouds table to the whole class during the class discussion time.

A cloud is visible mass of condensed water vapour floating in the atmosphere, high above the ground. As learnt earlier in the section of hydrological cycle, clouds are formed when the rising water vapour condenses due to the low temperatures in the atmosphere.

There are very many ways to classify and name clouds based on their size, shape, location etc. The most widely used method of classification classifies clouds into four types: cirrus, cumulus, stratus and nimbus.

Type of cloud and features	Appearance
<p><b>Cirrus</b></p> <p>These are whitish, wispy and hair-like clouds. They contain ice crystals. Located in very high altitude</p>	
<p><b>Cumulus</b></p> <p>These are detached clouds that look like white fluffy cotton balls. They are dense in appearance and have sharp outlines. The bases of cumulus are generally flat, They occur at the high altitude.</p>	

<p><b>Stratus</b></p> <p>These are broad and fairly widespread and appear like a blanket. Their edges are diffuse (spread out over a large area).</p>	
<p><b>Nimbus</b></p> <p>These are the dark rain clouds. They have the greatest vertical height.</p>	

### Exercise 15.7

1. What are clouds?
2. Name the different types of clouds.
3. What types of clouds are shown in Fig. 15.9. Give a reason for your answer.



*Fig. 15.9: Clouds*

4. Explain how clouds are formed.
5. Explain the term dew point temperature.

## 15.10 Cyclone and anticyclones

### Activity 15.15

### To explain the formation of cyclones and anticyclones

#### Materials

- Water
- internet
- Basin
- An atlas

#### Steps

1. Half fill the basin with water.
2. Dip your forearm into the water in the basin and whirl in the clockwise direction while inside the water. Observe the movement of the water in the basin.
3. Reverse the direction of whirling the water to anticlockwise. Observe the movement of the water in the basin.
4. Using your observation in steps 2 and 3, describe what cyclones and anticyclones are.
5. Use the Internet or an atlas to confirm your facts in step 4 and also identify areas on the earth surface where cyclones and anticyclones occur.

A cyclone (Fig. 15.10) is a large-scale, atmospheric wind-and-pressure system characterized by low pressure at its center and by circular wind motion, counterclockwise in the Northern Hemisphere, clockwise in the Southern Hemisphere.



Fig. 15.10: A cyclone in the northern hemisphere

An anticyclone is the reverse of a cyclone i.e, it is a large-scale circulation of winds around a central region of high atmospheric pressure, clockwise in the Northern Hemisphere, counterclockwise in the Southern Hemisphere".



Distinctive weather patterns tend to be associated with both cyclones and anticyclones. Cyclones (commonly known as lows, L) generally are indicators of rain, clouds, and other forms of bad weather. Anticyclones (commonly known as highs, H) are predictors of fair weather.

Fig. 15.11 illustrates cyclones and anticyclones in the northern and southern hemispheres.

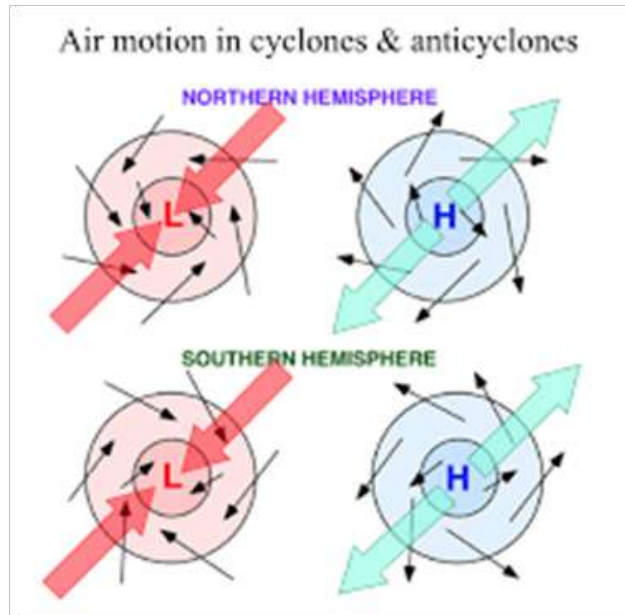


Fig. 15.11: Cyclones and anticyclone

**Cyclones**, also known as hurricanes or typhoons, are mainly caused by high ocean temperatures, broad-scale wind systems and clustered thunderstorms which liberate the heat energy from the ocean surface and transfer it to the **cyclone**

For a cyclone to form, the following conditions are required:

- The ocean water must be at least 26°C.
- The atmosphere must have a low air pressure
- A thunderstorm needs to be produced

Cyclones occur in the tropical regions on either side of the equator (between the Tropics of Cancer and Capricorn) where the above conditions are met

Due to the high temperatures in the tropics, warm air above the oceans rises carrying water vapour. As it rises, it cools. Since the cool air can't hold as much moisture as warm air, some water gets squeezed out of the condensing air and a cloud begins to form. If the warm air rises very quickly, this creates an **updraft**.

The water in the cloud builds up quickly and starts falling back to the ground as rain, drawing cool air down with it as a **downdraft**. As the simultaneous warm updraft and cool downdraft continues, the cloud grows and eventually become

a large thunderstorm cloud. Since there is low air pressure in the atmosphere in the tropics, the thunderstorm clouds begin to rotate due to the Earth spinning on its axis in a circular motion and a cyclone is created.

## 15.11 Global convective currents and wind patterns.

### Activity 15.16

To identify and explain the formation of global wind patterns

#### Materials

- An atlas
- Internet

#### Steps

1. From the knowledge you acquired in Unit 5, describe heat transfer by convection.
2. Use an atlas and Internet to describe the global convection currents and note down the facts in your notebook?
3. Present your facts to the rest of the class in a class discussion.

Convection is the transfer of heat energy by the movement of a liquid or gas particles. The hot fluid particles rise while the cold ones sink. The movement of these fluid particles, known as convective currents, spreads the heat to the entire fluid.

Globally, giant convective currents in the atmosphere are caused by temperature differences between the equator and the poles.

The Earth's curvature causes some parts to receive the Sun's rays more directly than other parts. For example, the Sun shines more directly on the surface at the equator than at the poles. As the warmer air over the equator rises, colder air from the poles rushes toward the equator to take its place. This steady exchange of warm and cold air between the equator and the poles produces global wind belts. The Earth's rotation causes the direction of the winds to bend slightly: toward the right in the Northern Hemisphere and toward the left in the Southern Hemisphere. Global winds push air masses around Earth and bring changes in the weather.

There are six major global wind belts namely Polar and Tropical Easterlies, the Prevailing Westerlies and the Intertropical Convergence Zone, Trade Winds, Doldrums, and Horse Latitudes (See Fig. 15.12).



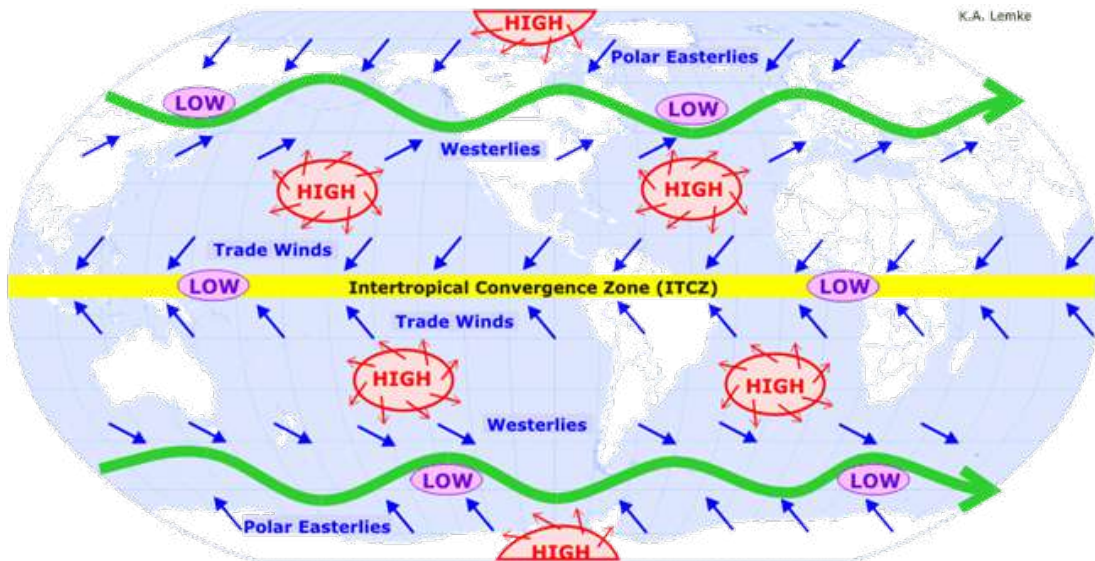


Fig. 15.12: Global wind belts

**Polar Easterlies** - Polar Easterlies are found at the north and south poles, between  $60^\circ$  and  $90^\circ$  latitudes in the southern and northern hemispheres. They are cold and dry because of the high latitudes of those regions. They form when the cool air at the poles moves towards the equator.

**Tropical Easterlies** - Tropical Easterlies flow east to west due to the rotation of the Earth. They form as the warm air from the equator rises, and on cooling down it comes back down to the equator. They are located between  $0^\circ$  and  $30^\circ$  latitude in both hemispheres.

**Prevailing Westerlies** - These wind belts are located between the  $30^\circ$  and  $60^\circ$  latitude in the northern and southern hemispheres. They blow from west to east.

**Intertropical Convergence Zone (ITCZ)** - This is also known as Equatorial Convergence Zone or the Intertropical Front. It is formed when southeast and northeast trade winds converge in a low-pressure zone near the equator. It usually appears as a band of clouds and comes with thunderstorms, which are short but produce extreme amounts of rain.

**Horse Latitudes** - They occur about  $30^\circ$ - $35^\circ$  degrees north and south of the equator. It is a region with weak winds because of high pressure and decreasing dry air.

**Trade Winds** - These winds blow from the horse latitudes to the low pressure of the ITCZ. They get their name from their ability of blowing trade ships across the ocean very quickly. In the northern hemisphere, they blow from the northeast, and are called Northeast Trade winds. In the Southern hemisphere, they blow from the southeast, and are called the Southeast Trade Winds.

**Doldrums** - They are also called Intertropical Convergence Zone, They occur 50° north and south of the equator the equator between the two belts of trade winds, due to the convergence of trade winds.

**The importance of wind include:**

1. Production of energy using wind turbines
2. It increases the rate of evaporation hence facilitates rainfall.
3. It is an agent of pollination and seed dispersal in plants.
4. Winds regulate the temperature in a region

## 15.12 Thermoregulation and the physics laws that govern it

### 15.12.1. Definition of thermoregulation

#### Activity 15. 17

#### To define thermoregulation

##### Materials

- Reference books
- Internet

##### Steps

1. Using the knowledge of science and biology, define the term thermoregulation.
2. How does thermoregulation work?
3. Name the types of thermoregulation.
4. Note down your findings in your notebooks.
5. Share your findings with your friend and then with the whole class
6. Discuss your findings as the whole class with the help of the teacher and note them down in your notebooks.

Thermoregulation is the process maintaining a constant body's internal core temperature despite temperature changes in the external environment.

A healthy person should have a temperature of between 37°C and 37.8°C. A temperature above or below this range may be an indication of ill-health or infection. Some factors that may raise the body temperature include ill-health or infection, exercise, digestion and being outdoors in a hot weather can also increase your temperature. Some factors that may lower the body temperature include being exposed to cold weather, drug and alcohol, and metabolic conditions like diabetes.

Let us now discuss some physics laws that govern thermoregulation

## 15.12.2 Laws of thermodynamics and thermoregulation

### The first law of thermodynamics and thermoregulation

The first law of thermodynamics states that, “The total amount of energy in an isolated system is conserved.” And is mathematically represented as

$$\Delta Q = \Delta U + \Delta W$$

Where  $\Delta Q$  is the heat supplied to or extracted from a closed system,  $\Delta U$  is the change in the internal energy of the system, and  $\Delta W$  is the work done by the system

The energy transfers in the body metabolic processes are governed by the first law of thermodynamics in order to maintain a constant body temperature (thermoregulation), as explained below.

The total energy produced in the body is called the metabolic rate ( $\Delta M$ ). It is related to the total metabolic energy production of the body ( $\Delta H$ ), and the external work done by the body ( $\Delta W$ ), by the expression:

$$\Delta M = \Delta H + \Delta W$$

For example, if no mechanical work is done ( $\Delta W = 0$ ), then the total chemical energy input in form of food is converted to thermal energy, i.e.  $\Delta H = \Delta U$ . If the human body does some work (i.e.  $\Delta W \neq 0$ ), then the total chemical energy input in form of food is converted to thermal energy and the work done by the body, i.e.

$$\Delta M = \Delta H + \Delta W$$

### The second Law of thermodynamics and thermoregulation

The law states that the spontaneous change for an irreversible process in an isolated system always proceeds in the direction of increasing entropy. In other words, the entropy of any isolated system always increases.

Simply put the law states that ‘heat flows spontaneously from a hotter object to a colder one, but not in the opposite direction; the reverse cannot happen without the addition of energy.

This law governs both the direction and attainment of equilibrium in body metabolic processes. The entropy change governs the direction in which a metabolic process will take and determines whether a particular process will occur or not. For example, in the oxidation of glucose, some amount of energy is lost as heat. This ‘wasted’ energy determines the direction in which a metabolic process should go, in this case, it raises the body temperature to maintain the core body temperature.

### 15.12.3 Modes of heat transfer and thermoregulation

**Convection** is the transfer of thermal energy by the motion of fluid particles. In a human body, the movement of body fluids e.g blood circulation facilitates heat transfer and distribution in the body through convection.

A warm body warms the surrounding air. Convection occurs in the surrounding air to diffuse the heat. This heat flow by convection facilitates faster cooling of the body; as cold air flows towards the body. Since convection is increased by wind, body movements increase the body's heat loss by convection, for example the 'pendulum' movement of the hands and limbs.

**Conduction** is the process by which heat energy is transferred between two points in a material at different temperatures.

The human body is a good conductor of heat. This is why when the body is touched with a hot object; the mind rapidly initiates a withdrawal mechanism to break the flow of heat by conduction. Air, being a poor conductor of heat, is used in most insulating systems, including clothing for human beings and fur and feathers for animals that act by trapping air. The air insulates the animal and humans from losing heat to the environment.

**Radiation** is the movement of heat through electromagnetic radiations. It does not necessarily require a medium. It plays an important role in the energy balance of human beings. The warm human body emits heat in form of infrared radiation. Similarly, the body absorbs heat from hot objects like hot walls and fire.

**Evaporation** is the process through which a liquid is transformed into vapour. For evaporation to take place, the liquid molecules absorb heat energy from the surrounding to change to gaseous state. As such evaporation causes cooling.

Evaporation plays key thermoregulation roles in animals and plants. As sweat vaporizes from the skin, it produces a net cooling effect on the body. Respiration (act of breathing) also produces some cooling effect on animals. This is why humans and animals sweat and pant heavily when involved in high metabolic activities that result in high heat energy emission e.g running. The rate of evaporation depends on the surface area on which evaporation is taking place, the temperature difference, the humidity, the rate of sweating and the velocity of wind. Some animals in hotter climates e.g the jackrabbit, (Fig. 15.13) have large ears (with large surface area) over which evaporation takes place resulting in cooling.



Fig. 15.13: Jackrabbit with large ears for cooling

### 15.12.4 Newton's law of cooling

Newton's law of cooling states that *the rate at which energy is lost from a body is directly proportional to the difference between the body's temperature and the environmental temperature*. This means that the greater the difference, the faster the rate of heat loss and vice versa. This is the reason why, animals loose heat and at a faster rate in cold weather since the difference between their body temperature and that of the environment is higher than is the case during in hot weather.

#### Exercise 15.8

**For questions 1 - 2, select the most appropriate response from the options given.**

- What is thermoregulation?
  - Control of body temperature
  - Control of water in the body
  - Control of glucose in the body
  - All the above
- How does sweat keep us cool?
  - Sweat cools us down
  - As sweat evaporates it takes heat with it
  - We don't sweat when hot
  - Heat is lost and gained.
- Explain how evaporation causes cooling.
- How does the first law of thermodynamics govern the maintenance of the core body temperature
- What factors influence the amount of energy that will be lost by the human body and the environment?
- With reference to the underlying Physics principles, mention two ways through which a human being can prevent himself/from from loosing too much body heat in a very cold region.
- How does hibernation help animals to conserve heat energy?
- Describe two ways through which animals dissipate excess heat.

#### Unit summary and new words

The natural environment consist of all living and non-living things occurring naturally on earth.

#### Laws of thermal dynamics and the environment

- The first law of thermodynamics states that energy cannot be created or destroyed but can be transformed from one form into another. This law governs energy transfer in the environment by ensuring that the total energy in all closed systems in the environment remains a constant.

- The second law of thermodynamics states that energy in all forms tends to transform itself spontaneously into a more dispersed, random, or less organised form. This law governs energy transfer in the environment by dictating the direction in which environmental processes will take i.e, to gain or lose energy and in what form.

### **Modes of heat transfer**

- The three modes of heat transfer are conduction, radiation and convection, but they rely on different physical interactions to transfer heat.
- Conduction is the transfer of heat energy or movement of heat through a substance without the movement of the particles of the substance. Example of heat flow by conduction in the environment is the flow of heat from a hot metal to the human body when one touches such a metal.
- Convection is the transfer of heat energy in a fluid by the movement of warmer and cooler fluid particles from place to place. It causes sea and land breezes and global convective currents.
- Radiation is the transfer of heat through electromagnetic waves. It enables energy to flow through the vacuum in space to reach the earth.

### **Noise pollution**

- Noise pollution is undesired sound that is disruptive or dangerous and can cause harm to life, nature and property.
- Effects of noise pollution include ear damage, headaches, stress, irritability, disruption of sleep, communication and natural order in an ecosystem, and structural damage to property like buildings.

### **Air pollution**

- Air pollution is the introduction of gases, dust particles, fumes (or smoke) or odour that are harmful to humans, animals and plants into the atmosphere.
- Causes of air pollution include emissions by industries, burning of fossil fuels, agricultural and household chemicals
- Effects of air pollution include chronic respiratory diseases and formation of acidic rain.

### **Climate change**

Climate change refers to the large-scale changes in the long-term averages of weather patterns.

- Some natural causes of climate change include, continental drift, volcanoes, the earth's tilt and ocean currents.
- Some human causes of climate change include engaging in activities that lead to ozone layer depletion and the greenhouse effect.



### **Ozone layer depletion**

- Ozone is a molecule made up of three oxygen atoms. The ozone layer is a layer in the earth's stratosphere that absorbs most of the ultraviolet radiation from the sun and prevent it from reaching the earth.
- Ozone layer is being destroyed by a group of manufactured chemicals, containing chlorine and/or bromine. The chemicals are called "ozone-depleting substances" (ODS). They include chlorofluorocarbons (CFCs) halons, methyl chloroform carbon tetrachloride and hydrofluorocarbons (HCFCs):
- Ozone depletion is the wearing out of the amount of ozone in the stratosphere
- Ozone depletion is due to chlorofluorocarbons (CFC's), substances produced by industries that manufacture soaps, insulating foams, air conditioners, which are heavier than air. UV radiations break them after they are taken into the stratosphere by wind and the breaking up releases chlorine, which reacts with the ozone, starting a chemical cycle that destroys ozone.

### **Greenhouse effect.**

- The greenhouse effect occurs as follows: The sunlight reaches Earth's surface, and is absorbed by the Earth or is reflected back into the atmosphere. Once absorbed, the earth releases some of the energy back into the atmosphere as heat in the form of infrared radiation. Greenhouse gases like water vapor ( $H_2O$ ), carbon dioxide ( $CO_2$ ), and methane ( $CH_4$ ) and Nitrous oxide ( $N_2O$ ) in the atmosphere are responsible for absorbing the heat energy from the earth and radiating it back to the earth.
- Human activities that produce greenhouse gases include burning coal, oil and gas, deforestation, use of fertilisers containing oxygen and production of fluorinated gases.
- The main effect of greenhouse effect is global warming.
- Measures that reduce the greenhouse effect and global warming include reducing the use of fossil fuels, Use of green energy, and afforestation:

### **Global warming**

- Global warming is the increase of earth's average surface temperature.
- Some results of global warming include changes in rainfall averages and patterns and sea level rises

### **Hydrosphere and hydrological cycle**

- The hydrosphere is the combined mass of water found on, under, and over the surface of a planet or is the liquid water component of the Earth.
- The hydrological cycle is a conceptual model that describes the storage and movement of water between the biosphere, atmosphere, lithosphere and the hydrosphere.

- Some of the uses of water include being a component of all body fluids, transport in plants, photosynthesis, industrial use, recreation and as a habitat for marine animals

### **Clouds**

- A cloud is a visible mass of condensed watery vapor floating in the atmosphere, typically high above the general level of the ground.
- Clouds are generally classified into 4 broad categories: cirrus, stratus, cumulus, and nimbus.

### **Cyclones and anti-cyclones**

- A cyclone is a large-scale, atmospheric wind-and-pressure system characterized by low pressure at its center and by circular wind motion, counterclockwise in the Northern Hemisphere, clockwise in the Southern Hemisphere.
- An anticyclone is a large-scale circulation of winds around a central region of high atmospheric pressure, clockwise in the Northern Hemisphere, counterclockwise in the Southern Hemisphere".

### **Convection currents and global wind patterns**

- A convection current is the circular movement of air caused by the cycle of warm air rising and cool air sinking. These currents cause the global wind patterns.

### **Thermoregulation**

- Thermoregulation is the process of maintaining a body's constant internal core temperature despite temperature changes in the external environment.
- Thermoregulation is governed by the following Physics laws and principles:
- The laws of thermodynamics
- Modes of heat transfer (conduction, convection, radiation)
- Evaporation
- Newton's law of cooling and
- Gibbs free energy law



**Unit Test 15**

**For questions 1-12 select the most appropriate answer**

- The energy of an isolated system
  - Is always decreasing
  - Is always constant
  - Is always increasing
  - None of the above
- The term which can differentiate thermodynamics from other sciences is \_\_\_\_\_
  - Pressure
  - Temperature
  - Mass
  - None of the above
- The thermodynamic work done by a system on the surrounding is considered as \_\_\_
  - Positive
  - Negative
  - Neutral
  - None of the above
- When the heat transfer into the system is more than the work transfer out of the system, then
  - The internal energy of the system remains constant
  - The internal energy of the system decreases
  - The internal energy of the system increases
  - None of the above
- How does the heat transfer take place in metals?
  - Volumetric density
  - Transporting energy with free electrons
  - Unstable elastic collision
  - Random molecular collision
- Mass transfer does not take place in
  - Conduction heat transfer
  - Convection heat transfer
  - Radiation heat transfer
  - None of the above
- What is the condition for conduction mode of heat transfer between two bodies?
  - The two bodies must be in physical contact
  - There must be a temperature gradient between the bodies
  - Both A and B
  - None of the above
- Ozone layer is present in which of the following layers of earth
  - Stratosphere
  - Ionosphere
  - Troposphere
  - Mesosphere

9. What is the earth's hydrosphere?
- A. The gases in the air
  - B. The solid, rocky part of the earth
  - C. All of the water on the planet
  - D. The study of the earth's atmosphere
10. During evaporation, water goes from a \_\_\_\_\_ to a \_\_\_\_\_.
- A. Liquid, solid
  - B. Liquid, gas
  - C. Solid, gas
  - D. Liquid, plasma
11. Clouds form through the process of
- A. Transpiration
  - B. Evaporation
  - C. Infiltration
  - D. Condensation
12. \_\_\_\_\_ is the only substance on the earth that exists in all of the three states of matter
- (a) Milk
  - (b) Oil
  - (c) Water
  - (d) Paraffin
13. Describe the causes of global warming and suggest strategies that could be adopted to overcome it.
14. What are climate change and global warming and how are they related?
15. (a) What is ozone and where is it found in the atmosphere?  
(b) How is ozone formed in the atmosphere?  
(c) What emissions from human activities lead to ozone depletion?
16. Explain the statement "the energy of an isolated system is always constant."
17. Name the chemicals, which are used in refrigerators and air conditioners and damage ozone layer when released in air.
18. What do CFCs stand for?
19. Name some devices where CFCs are used.
20. Why are CFCs considered as pollutants?
21. It's said "carbon dioxide contribute to global warming" explain.
22. Write down the principle steps in stratospheric ozone depletion caused by human activities in the right order.

## Appendix AP1

### Quantities and Units of Magnetism

**Magnetic flux ( $\Phi$ ):** is a measure of the quantity of magnetism, being the total number of magnetic lines of force passing through a specified area in a magnetic field. It represents the strength of the magnetic field over a given area. The SI unit is weber (symbol Wb).

**Magnetic flux density (B) or magnetic induction** is the amount of magnetic flux through a unit area taken perpendicular to the direction of the magnetic flux, a vector quantity measuring the strength and direction of the magnetic field around a magnet or an electric current. It is equal to magnetic field strength times the magnetic permeability in the region in which the field exists. The SI unit is **tesla** (symbol T), or  $N/(A \cdot m)$  expressed in SI base unit.

**Magnetic field strength (H)** is the intensity of a magnetic field at a given location, a vector quantity indicating the ability of a magnetic field to exert a force on moving electric charges. It is equal to the magnetic flux density divided by the magnetic permeability of the space where the field exists. SI derived unit is amperes per meter (symbol A/m).

**Magnetomotive force, or magnetic potential difference,** is any physical cause that produces magnetic flux. It is analogous to electromotive force. The SI unit is ampere (symbol A). The obsolete unit ampere turn.

**Reluctance**— (The opposition to magnetic field flux through a given volume of space or material. Analogous to electrical resistance.

**Permeability ( $\mu$ )** The specific measure of a material's acceptance of magnetic flux. Its SI units are Newtons per square metre

**Inductance (L) or self inductance** is the property of an electrical circuit to oppose a change in current. The moving magnetic field produced by a change in current causes an induced voltage to oppose the original change. The ratio of the magnetic flux produced to the current is called the inductance. SI unit is henry (symbol H), or Weber per ampere.



## Appendix AP2

### Relationship between linear and angular displacements and velocities

#### AP2.1 Angular displacement and angular velocity

##### Angular displacement

Consider a particle moving along a circular path. As the particle moves along the arc of the circle from A to B (Fig. AP2.1) the line OA (radius  $r$ ) joining the particle to the centre of the circle sweeps through an angle  $\theta$ . The angle swept is called *angular displacement*. It is measured in *radian*.

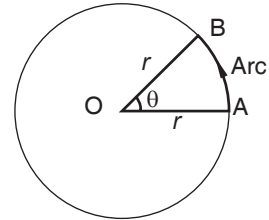


Fig. AP2.1: Angular displacement

In Fig. AP2.2(a), the length of the arc AB is equal to the radius  $r$  of the circle. The angle subtended by this arc at the centre of the circle is equal to *one radian*. *One radian is the angle subtended at the centre of a circle by an arc of length equal to the radius of the circle*. If the length of the arc is 2 times the radius, then the angular displacement is 2 radians. For the whole circle, the length of the arc is its circumference, i.e.  $(2\pi r)$ . The angular displacement is therefore  $2\pi$  radians (Fig. AP2.2(b)).

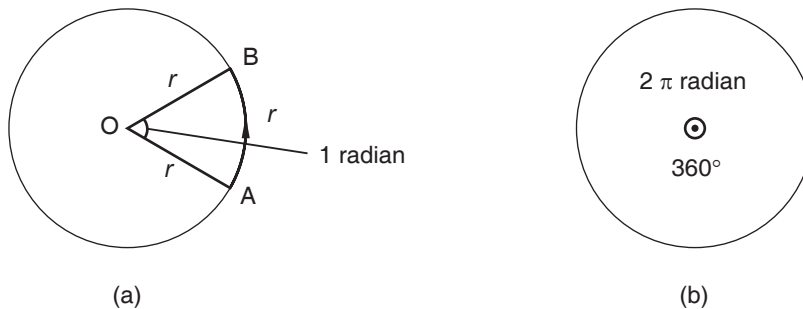


Fig. AP2.2: The radian measure

*Note:*  $\theta$  radians is also denoted as  $\theta$  rad or  $\theta^\circ$

The angle at the centre of a circle is  $2\pi$  radians. It is also equal to  $360^\circ$ . Therefore,

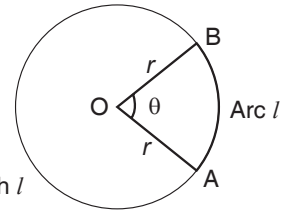
$$2\pi \text{ radians} = 360^\circ$$

From this, we see that,

$$1 \text{ radian} = \frac{360^\circ}{2\pi} = 57.3^\circ$$

If the angle at the centre of a circle is 1 radian, then the length of the arc is  $r$  units. If the angle at the centre is  $\theta$  radians (Fig. AP2.3), the length  $l$  of the arc AB of the circle is given by

$$l = \frac{r}{1 \text{ rad}} \times \theta \text{ rad} = r\theta$$



Arc length  $l = r\theta$

Fig. AP2.3: Arc length  $l$

### Example AP2.1

The radius of a particle moving along a circular path sweeps through an angle of  $60^\circ$  at the centre of the circle. Calculate the angular displacement of the particle in radians.

### Solution

$$360^\circ = 2\pi \text{ rad} \Rightarrow 1^\circ = \frac{2\pi}{360^\circ} \text{ rad}$$

$$\text{Hence, } 60^\circ = \frac{2\pi}{360^\circ} \times 60^\circ = \frac{\pi}{3} \text{ radians}$$

Angular displacement of the particle =  $\frac{\pi}{3}$  radians or 1.05 rad.

### Angular velocity

A body moving from point A to point B in a straight line (Fig. AP2.4) has *linear velocity*. Linear velocity ( $v$ ) is defined as the rate of change of linear displacement.

$$\text{Linear velocity } v = \frac{\text{linear displacement}}{\text{time}} = \frac{x}{t}$$

A body moving from point A to B in a circular motion (Fig. AP2.5) has



Fig. AP2.4: Linear velocity

*angular velocity* ( $\omega$ ). Angular velocity is defined as *the rate of change of angular displacement*. Consider a particle moving along a circular path covering an arc of length AB in a time,  $t$  (Fig. AP2.5). The angular displacement of the radius OA is  $\theta$  in the same time  $t$ . Hence

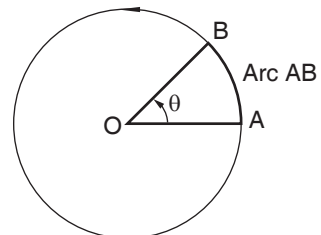


Fig. AP2.5: Angular velocity

angular velocity,  $\omega = \frac{\text{angular displacement}}{\text{time}} = \frac{\theta}{t}$

Angular velocity is expressed in radians per second (rad/s)

***Relationship between angular velocity and frequency***

***Relationship between angular velocity and frequency***

For one complete circular motion,  $\theta = 360^\circ = 2\pi$  radians and the time taken  $t = T$ , (referred to as the periodic time).

$$\text{Hence, } \omega = \frac{\theta}{t} = \frac{2\pi}{T}$$

Since the frequency of revolution  $f = \frac{1}{T}$ , we have  $\omega = 2\pi f$ .

Therefore: angular velocity =  $2\pi \times$  frequency or  $\omega = 2\pi f$

***Relationship between the angular velocity and the linear speed***

We have seen that the arc length  $l = r\theta$ .

Dividing both sides by  $t$ , we have,

$\frac{l}{t} = \frac{r\theta}{t}$  But  $l/t$  is the linear speed  $v$  of the rotating particle and  $\theta/t$  is its angular velocity,  $\omega$ . Therefore

$$\begin{aligned} \text{Linear speed, } v &= \text{radius}(r) \times \text{angular velocity}(\omega) \\ v &= r\omega \end{aligned}$$

## GLOSSARY



- **Linear motion** – is a motion along a straight line, and can therefore be described mathematically using only one spatial dimension.
- **Uniform motion** – is the kind of motion in which a body covers equal distances in equal intervals of time. It does not matter how small the time intervals are, as long as the distances covered are equal. If a body is involved in rectilinear motion and the motion is uniform, then the acceleration of the body must be zero.
- **Uniform motion** – is the kind of motion in which a body covers unequal distances in equal intervals of time, no matter how small the time intervals.
- **Momentum** – is the quantity of motion that an object has. A sports team that is on the move has the momentum. If an object is in motion (on the move) then it has momentum. Momentum can be defined as "mass in motion".
- **Inertia** – is a property of matter by which it continues in its existing state of rest or uniform motion in a straight line, unless that state is changed by an external force.
- **Elastic collision** – is defined as one in which there is no loss of kinetic energy in the collision. An inelastic collision is one in which part of the kinetic energy is changed to some other form of energy in the collision.
- **Inelastic collision** – is a collision in which kinetic energy is not conserved due to the action of internal friction. In collisions of macroscopic bodies, all kinetic energy is turned into vibrational energy of the atoms, causing a heating effect, and the bodies are deformed.
- **Coefficient of friction** – is the ratio between the force necessary to move one surface horizontally over another and the pressure between the two surfaces.
- **Kinetic energy** – is the energy possessed by a body by virtue of its motion. It depends on the mass and the speed of the object.
- **Kinetic theory** – is the explanation of the way molecules behave- states that all matter is made up of small particles called atoms or molecules which are constantly moving and collide without losing energy
- **Law of conservation of energy** – states that energy can neither be destroyed nor created but changes from one form to another.
- **Non-renewable resources** – are sources of energy that will run out or will not be replenished in our lifetime. They include fossil fuels
- **Atmospheric pressure** – is the pressure exerted by the weight of the air column, which at sea level has a mean value of 101,325 Pascal's (roughly 14.6959 pounds per square inch).

- **Heat** – is thermal energy. It can be transferred from one place to another by conduction, convection and radiation. Conduction and convection involve particles, but radiation involves electromagnetic waves.
- **Convection** – transfer of heat in a fluid by the movement of warmer and cooler fluid from one place to another.
- **Conduction** – is the transfer of heat energy through a substance without the movement of the substance from a place of higher temperature to a place of lower temperature.
- **Radiant energy** – energy carried by an electromagnetic wave.
- **Thermal expansion** – is the tendency of matter to change in shape, area, and volume in response to a change in temperature. Temperature is a monotonic function of the average molecular kinetic energy of a substance. When a substance is heated, the kinetic energy of its molecules increases.
- **Heat capacity** – is the number of heat units needed to raise the temperature of a body by one degree.
- **Second law of thermodynamics** – states that heat flows from a hotter object to a colder one, but not in the opposite direction, the reverse cannot happen without the addition of energy.
- **Solar collector** – device used in an active solar heating system that absorbs radiant energy from the sun.
- **Sublimation** – is the process of a solid changing directly to vapor without forming a liquid.
- **Temperature** – measure of the average kinetic energy of all the particles in an object.
- **Thermal energy** – sum of the kinetic and potential energy of the particles in an object.
- **Thermodynamics** – is the study of the relationship between thermal energy, heat and work.
- **Electromagnetic induction** – is a process where a conductor placed in a changing magnetic field (or a conductor moving through a stationary magnetic field) causes the production of a voltage across the conductor.
- **A transformer** – is an electrical device that transfers electrical energy between two or more circuits through electromagnetic induction
- **Eddy currents (also called Foucault currents)** – are loops of electrical current induced within conductors by a changing magnetic field in the conductor, due to Faraday's law of induction. Eddy currents flow in closed loops within conductors, in planes perpendicular to the magnetic field.
- **Electric field** – is a region where a charged body experiences a force



- **Electric field intensity** – is the measure of the strength of an electric field at a specified point.
- **Electric field line** – is a path along which a unit positive charge would tend to move in the electric field.
- **First law of thermodynamics** – states that the increase in internal energy of the system equals the work done on the system plus the heat added to the system.
- **A light-emitting diode (LED)** – is a two-lead semiconductor light source. It is a p–n junction diode that emits light when activated. When a suitable voltage is applied to the leads, electrons are able to recombine with electron holes within the device, releasing energy in the form of photons.
- **In electrical engineering, ground or earth** – is the reference point in an electrical circuit from which voltages are measured, a common return path for electric current, or a direct physical connection to the Earth.
- **A lightning arrester** – is a device used on electrical power systems and telecommunications systems to protect the insulation and conductors of the system from the damaging effects of lightning. The typical lightning arrester has a high-voltage terminal and a ground terminal.
- **Electrical impedance** – is the measure of the opposition that a circuit presents to a current when a voltage is applied. In quantitative terms, it is the complex ratio of the voltage to the current in an alternating current (AC) circuit..
- **Climate** – is the average of the prevailing weather conditions in a region over a long period of time, usually a year.
- **Climate change** – is the large-scale changes in the long-term averages of weather patterns
- **Cloud** – is a visible mass of condensed water vapor floating in the atmosphere high above the ground
- **Decibel** – unit for sound intensity; abbreviated as dB
- **Fossil fuels** – are non-renewable sources of energy made mainly of carbon. They include coal, oil and natural gas
- **Geothermal energy** – is heat from the earth, can be converted into electrical energy by power plants.
- **Generator** – is a device that converts mechanical energy into electrical energy
- **Global warming** – is the rise of the average global temperatures.
- **Ozone** – is a molecule made up of three oxygen atoms.
- **Loudness** – the human perception of sound intensity.
- **Melting point** – the temperature at which a substance (solid) changes into a liquid at that temperature.

## References



- REB, R. (2015). Ordinary Level Physics Syllabus, Kigali: Ministry of Education.
- Abbot A. F., (1977), Ordinary Level Physics, Heinemann Educational Publishers, 3rd Edition.
- Atkinson A., Sinuff H (1987), New Complete Junior Physics, Longhorn Publishers, Nairobi.
- Tom, D. (2000). Advanced Physics. London: Hodder Education.
- Duncan T (1990 ), Physics for Today and Tomorrow, Trans-Atlantic Publications, Inc.; 2nd edition.
- Malawi Institute of Education (2013), Malawi Junior Secondary Syllabus for Form 3 and 4 Physics, Domasi
- Nelkon M (1990), Principles of Physics, Longman, 8th Edition
- Kariuki C (2004), Longhorn Secondary Physics Form 3, Longhorn Publishers , Nairobi.
- Apple Dictionary.